

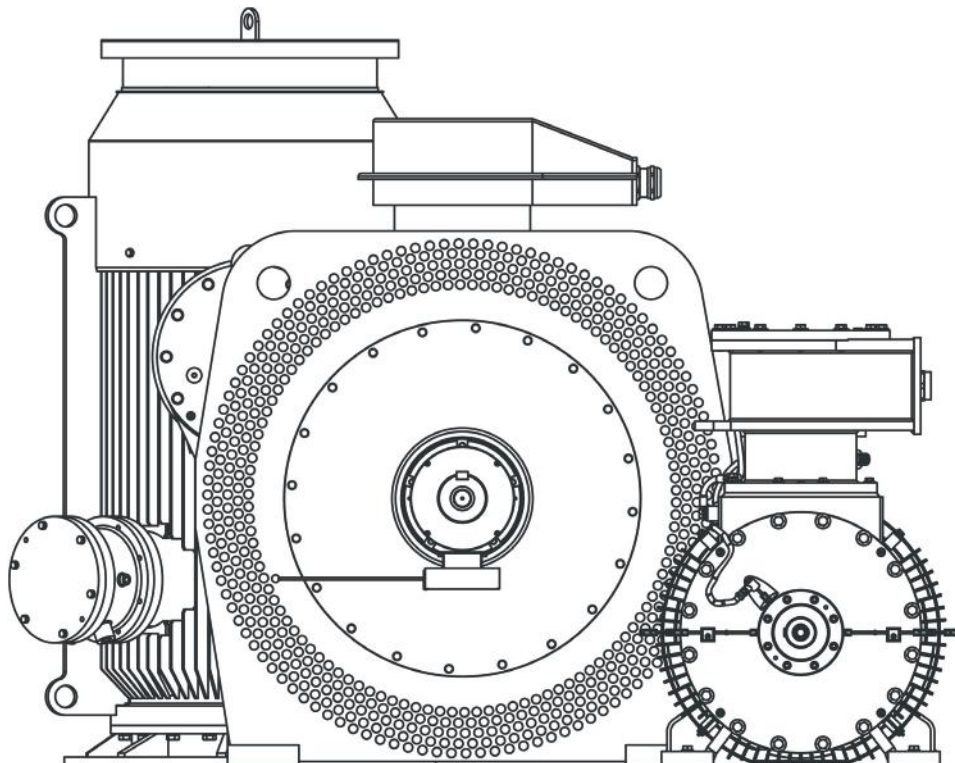

HELMKE
High-Voltage Motors with
Flameproof Enclosure
Ex d IIC T4 Gb
Ex d e IIC T4 Gb



Contents

1	General information	5
1.1	Standards and regulations	5
1.2	Explosion protection in the hazard zones	5
1.3	Motors product range.....	11
2	Mechanical characteristics	13
2.1	Setup conditions	13
2.2	Model for lowest temperatures with stationary heating	13
2.3	Material	14
2.4	Paint.....	14
2.5	Shaft ends, balancing, vibrations, noise level and coupling	14
2.6	Types	15
2.7	Belt drive.....	16
2.8	Terminal boxes	16
3	Electrical characteristics	17
3.1	Conditions for rated operation.....	17
3.2	Tolerances	17
3.3	Insulation and heating.....	18
3.4	Circuitry.....	18
3.5	Motor protection	18
3.6	Alternating current motors with cage rotors in operation on the frequency inverter	20
4	Operating data	21
4.1	Overview.....	21
4.2	Bearings.....	22
4.3	Technical data of standard motors.....	25
4.4	Dimensions of motors with frame sizes 355–500 (standard design)	28
5	Mechanical execution and variants	30
5.1	Standard machine design	30
5.2	Terminal box versions.....	32
5.3	Customized designs.....	35
6	Spare parts	38
7	Notes	39

Changes reserved

Changes to the services, technical data, dimensions and weight specified in this list remain reserved.
The illustrations are non-binding.

1 General information

1.1 Standards and regulations

The motors comply with the relevant standards and regulations, in particular:

Electrical

IEC standard	EN standard	Contents
IEC 60034-1	EN 60034-1	Rotating electrical machines – Part 1: Rating and performance
IEC 60034-8	EN 60034-8	Rotating electrical machines – Part 8: Terminal markings and direction of rotation
IEC 60079-0	EN 60079-0	Explosive atmospheres – Part 0: Equipment – General requirements
IEC 60079-1	EN 60079-1	Explosive atmospheres – Part 1: Equipment protection by flameproof enclosures “d”
IEC 60079-7	EN 60079-1	Explosive atmospheres – Part 7: Equipment protection by increased safety “e”
IEC 60079-31	EN 60079-31	Explosive atmospheres – Part 31: Equipment dust ignition protection by enclosure “t”

Mechanical

IEC standard	EN standard	Contents
IEC 60072	EN 50347	Dimensions and output
IEC 60034-5	EN 60034-5	Rotating electrical machines – Part 5: Degrees of protection provided by integral design of rotating electrical machines (IP-Code) – Classification
IEC 60034-6	EN 60034-6	Rotating electrical machines – Part 6: Methods of cooling (IC-Code)
IEC 60034-7	EN 60034-7	Rotating electrical machines – Part 7: Classification of types of construction, mounting arrangements and terminal box position (IM-Code)
IEC 60034-9	EN 60034-9	Rotating electrical machines – Part 9: Noise limits
IEC 60034-14	EN 60034-14	Rotating electrical machines – Part 14: Mechanical vibration of certain machines with shaft heights 56 mm and higher – Measurement, evaluation and limits of vibration severity

1.2 Explosion protection in the hazard zones

Protection classes

The use of electrical machines in areas with explosion hazard is permissible on certain conditions. The machines must be designed in such a way that the explosion risk is eliminated to the furthest extent possible. An explosion may occur under the following conditions:

- ▶ there is an explosive atmosphere;
- ▶ there is the risk of a spreading explosion;
- ▶ there are sources of ignition.

The ignition protection classes Ex d and Ex d e prevent one of the three conditions if gas is present and make an explosion impossible.

The ignition protection class for gas, Ex d e, represents a combination of:

- ▶ pressure-resistant enclosure “d” for the motor housing;
- ▶ increased safety “e” for the terminal box.

Hazardous areas and zones

Hazardous areas are places where an explosive atmosphere may form under certain conditions.

An explosive atmosphere consists of a mixture of air and gasses, steams, mists and flammable dusts, in which a fire spreads quickly upon ignition under normal air pressure (explosion).

The user is obligated to apply the classification of the hazardous areas under own responsibility and in accordance with the European Directive 1999/92/EC.

The international standards EN / IEC 60079-10-1 and 60079-10-2 provide the criteria for the classification of the hazardous areas based on the chemical properties, physical properties, and the quantity of materials used, as well as in dependence on the frequency and duration in time when an explosive mixture may form.

Zones with explosive gas atmosphere

If the hazard is due to the presence of gas, steams or mists of flammable materials, the European Directive 1999/92/EC provides for a classification into the following three areas:

Zone 0 – areas in which an explosive atmosphere is present permanently or for long periods. In this area, the installation of electrical machines requires double protection.

Zone 1 – areas in which it is likely that an explosive atmosphere can form under normal conditions. In this zone, explosion-protected electrical motors with pressure-resistant enclosure, overpressure enclosure, or such with increased safety may be installed if a certificate from an accredited institution in accordance with the ATEX Guideline is provided.

Zone 2 – areas in which an explosive atmosphere can form only in very rare cases and can remain there only for a short period. In this zone, non-sparking motors may also be set up besides motors with pressure-resistant enclosure, overpressure enclosure or motors with increased safety. The certificate from an accredited institution is not required.

Zones with flammable dust formation

If the hazard is due to the presence of ignitable, flammable dust, the European Directive 1999/92/EC provides for a classification into the following three zones:

Zone 20 – areas in which an explosive atmosphere is present permanently or for long periods. There are no motors installed in this zone.

Zone 21 – areas in which it is likely that an explosive atmosphere can form under normal conditions. In this zone, electrical motors may be installed if a certificate from an accredited institution in accordance with the ATEX Guideline is provided and if they are installed with protection class IP6x.

Zone 22 – areas in which an explosive atmosphere can form only in very rare cases and can remain there only for a short period. Depending on the kind of dust, protection class IP6x may also be required in Zone 22. The certificate from an accredited institution is not required.

Classification of hazard zones

Area of use with presence of GAS	Area of use with presence of FLAMMABLE DUSTS	Hazard class of the setup zone
Zone 0	Zone 20	Explosive atmosphere is present permanently
Zone 1	Zone 21	Explosive atmosphere is probably present
Zone 2	Zone 22	Explosive atmosphere is unlikely

Classification of equipment according to ATEX

The European ATEX Directive 2014/34/EC classifies equipment into two equipment groups, each with up to three different device categories, depending on the safety standard reached by the machine.

	Machines of a higher equipment category can also be installed at the setup sites of machines in a lower equipment category, due to the given redundancy.
---	--

Equipment category

Degree of protection ensured by the equipment	Pits Equipment Group I	Surfaces Equipment Group II	
	Equipment categories	Equipment Categories Gas	Equipment Categories Flammable dusts
Very high	M1	1 G	1 D
High	M2	2 G	2 D
Normal	Not provided	3 G	3 D

Group classification of equipment according to EN / IEC 60079-0

The EN / IEC 60079-0 standard classifies the electrical equipment into three groups.

Group I: Electrical equipment intended for installation in workings with hazard of firedamp.

Group II: Electrical equipment intended for areas, other than workings, in which an explosive gas atmosphere may form.

Group III: Electrical equipment intended for areas, other than workings, in which an explosive dust atmosphere may form.

The motors and other electrical equipment are labelled with the special symbols of the ignition protection class, explosion group, temperature class and the equipment protection level.

Equipment for explosive gas atmospheres

Flammable gases and steams are classified into explosion groups and temperature classes, depending on the ignition temperature and pressure that is created in the event of an explosion.

The housings, components and additional parts of equipment that is intended for the use in gas atmospheres, are classified into three subgroups, depending on the flammable materials for which they are suited:

- ▶ Group IIA, Group IIB, Group IIC

A motor that is classified for a particular group is also suitable for the lower groups: A motor of Group IIB is also suitable for Group IIA; a motor of Group IIC is also suitable for Groups IIA and IIB.

Temperature classes are defined for the different ignition temperatures of gasses, steams and mists, from which the use and labelling is derived.

Temperature classes

Ignition temperature of the explosive mixture [°C]	Temperature class	Maximum surface temperature of the electrical equipment [°C]
above 450	T1	450
from 300 to 450	T2	300
from 200 to 300	T3	200
from 135 to 200	T4	135
from 100 to 135	T5	100
from 85 to 100	T6	85

The data listed in the table serve merely as examples.



The equipment manufacturer is not responsible for the classification of the materials. The user is responsible for selecting the equipment (see EN / IEC 60079-14).

Classification of the most frequently occurring flammable materials, by explosion group and temperature class

Group	Temperature class					
	T1	T2	T3	T4	T5	T6
I	Methane (firedamp)					
IIA	Ammonia Ethane Ethyl acetate Acetone Benzol Butanone Methylene chlorine Chloroethylene Acetic acid Carbon monoxide Methane Methanol Methyl alcohol Methyl acetate Naphthalene Propane Toluene Xylene	Amyl alcohol Ethyl alcohol Butyl acetate Natural gas Acetic acid anhydride Liquid gas Isobutyl alcohol Monoamine acetate N-butyl alcohol Propyl acetate Cyclohexane	Decane Diesel fuel Crude oil* Heptane Hexane Kerosene Naphtha Pentane Cyclohexane Cyclohexene	Ether Acetaldehyde		
IIB	Coke gas Water gas	1.3-butadien Ethylene Ethyl benzene Ethylene oxide	Crude oil* Isoprene Hydrogen sulphide	Ethyl ether		
IIC	Hydrogen	Acetylene				Ethyl nitrate Carbon disulphide

* in the function of the chemical composition

Equipment for explosive dust atmospheres

The housing of the devices with ignition protection class "t", which are intended for the use in atmospheres with explosive dust, are classified into three subgroups depending on the kind of dust:

- ▶ IIIA: flammable fibrous material
- ▶ IIIB: non-conductive dust
- ▶ IIIC: conductive dust



Group IIIC also requires at least protection class IP6x even if it is set up in Zone 22.

Temperature for environments with flammable dust

To protect against flammable dusts, the ignition temperature of the dusts must be considered both in the form of a dust cloud as well as in the form of a dust layer.

The surface temperature of the enclosure specified on the motor type plate must be lower than the reference ignition temperature.

The reference temperature is the lower value of the two values calculated according to the following method:

- ▶ $T_{S1} = 2/3 T_{cl}$ (T_{cl} = ignition temperature of the dust cloud)
- ▶ $T_{S2} = T_{5mm} - 75 K$ (T_{5mm} = ignition temperature of a dust layer of 5 mm).
- ▶ T_{amm} = the lower value of T_{S1} and T_{S2} .

The surface temperatures are not specified in temperature classes as is the case for explosive gases, but directly in degrees Celsius. The manufacturer determines the temperature by means of the thermal characteristics of the product. The following surface temperatures apply as a standard for HELMKE products:

T150°C – T135°C – T125°C – T100°C – T85°C.

The data listed in the table serve merely as examples.



The equipment manufacturer is not responsible for the classification of the materials. The user is responsible for the choice of equipment.

Examples of ignition temperatures of flammable dust

	Clouds [°C]	Layer [°C]
Aluminium	590	>450
Coal dust	380	225
Meal	490	340
Wheat dust	510	300
Methyl cellulose	420	320
Phenolic resin	530	>450
Polyethylene	420	Melting point
PVC	700	>450
Soot	810	570
Starch	460	435
Sugar	490	460

Equipment Protection Level (EPL)

In accordance with the standard EN / IEC 60079, the labelling of equipment that is intended for use in a potentially explosive atmosphere must also include the additional specification of the Equipment Protection Level (EPL).

The EPL is defined as the protection level attributed to equipment, which is based on the probability that equipment can represent a source of ignition.

The EPL labelling furthermore permits distinguishing between different explosive atmospheres.

The first letter distinguishes between the following:

- ▶ M – for mining
- ▶ G – for gas
- ▶ D – for dust

The second letter indicates the probability that equipment can represent a source of ignition:

- a - Equipment with “very high” protection level (guarantees safety in normal operations as well as in the case of predictable or rare errors/malfunctions);
- b - Equipment with “high” protection level (guarantees safety in normal operations as well as in the case of predictable errors/malfunctions);
- c - Equipment with “expanded” protection level (there is no hazard of ignition during normal operations; the device has a few additional protection features, which ensure that there is no hazard of ignition in the case of normally predictable failures).

Choice of the electrical explosion-protection

The combination of hazard zones and the equipment categories to be used is defined by Directive 1999/92/EC. Notes on this topic are also provided in EN / IEC 60079-14.

The special construction standards for the protection classes (e. g. Ex d) also determine the motor category (e. g. 2 G) that is permissible for their use.

Examples for the choice of protection class for the ZONES with GAS atmosphere

Explosive atmosphere	Hazard zone	Protection ensured by the equipment	Motor category	Protection class
ALWAYS PRESENT	0	Very high	1 G	See EN / IEC 60079-26
PROBABLE	1	High	2 G	Ex d Ex d e Ex e Ex p
NOT PROBABLE	2	Normal	3 G	Ex nA

Examples for the choice of protection class for areas with flammable dust

Explosive atmosphere	Hazard zone	Protection ensured by the equipment	Motor category	Protection class
ALWAYS PRESENT	20	Very high	1 D	Ex ta
PROBABLE	21	High	2 D	Ex tb
NOT PROBABLE	22 Conductive dust	Normal	3 D	Ex tc IIIC
NOT PROBABLE	22 Non-conductive dust or fibrous material	Normal	3 D	Ex tc IIIB Ex tc IIIA

Comment: Machines of a higher equipment category can also be installed at the setup places of machines in a lower equipment category.

1.3 Motors product range

The motors described in this catalogue fulfil the requirements in accordance with the European Directive 2014/34/EC (ATEX Directive) regarding machines and protection equipment for the use in safe areas or in areas with a potential explosion hazard.

	The user is responsible for the classification of the areas.
---	--

Temperature class

Type	T3	T5	T6
355-500	Same output as T4	Same output as T4	Reduced output compared to T4

Basic characteristics

- ▶ Explosion-proof motors, which are protected against explosion according to the standards EN / IEC 60079-0, 60079-1, 60079-7 for gaseous environments. Asynchronous alternating current motors with cage rotors.
- ▶ Asynchronous alternating current motors with cage rotors.
- ▶ Completely enclosed, self-ventilated, housing IP55 with terminal box IP65.
- ▶ The motors are air-cooled with external ventilation (standard EN / IEC 60034-6, Method IC411).
- ▶ Axial or radial fan wheel dependend or independent of rotation direction.
- ▶ Dimensions according to the standards EN 50347 / IEC 60072.
- ▶ Power supply 6000 V / 50 Hz as standard. Alternating current motors, one rotation speed, 2-4-6 poles, T4 for design sizes from 355 mm to 500 mm, power supply with multi-range voltage and frequency upon by customer's request.
- ▶ Insulation class F.
- ▶ Maximum sound pressure level 86 dB(A).
- ▶ Terminal box:
 - available both as flame proof "d" and increased safety "e" constructions,
 - in enlarged design,
 - pivotable by 90° in 4 positions.
- ▶ Motor housing and terminal boxes are separated by design to avoid the spreading of explosions.
- ▶ Type plate made of stainless steel, corrosion protected screws.
- ▶ Strong impact resistance:
 - motor housing, terminal boxes and bearing shields are steel welded constructions.
 - ventilator and ventilator hub made of steel sheet.
- ▶ The declaration of conformity is also available for special product characteristics that are different from the basic version, such as:
 - operation above 1000 m absolute altitude,
 - different voltages and frequencies,
 - supply through frequency inverter,
 - built-in temperature sensors in the motor,
 - operating modes from S1 to S9.

Electrical design variants

- ▶ Special voltages and frequencies (max. voltage 6600 V).
- ▶ Motors for tropical climatic zones.
- ▶ Motors for low ambient temperatures (-50 °C).
- ▶ Stator winding over temperature below 80 K.
- ▶ Motors of insulation class F.
- ▶ Motors with bi-metal contacts, PTC-thermistors or PT100 temperature sensors.
- ▶ Motors with stationary heating.
- ▶ Motors with electrical characteristics according to customer specifications.

Mechanical design variants

- ▶ Special flanges and shafts.
- ▶ Second shaft end (NDE).
- ▶ Terminal box with cable glands.
- ▶ Terminal box with special wire inlets.
- ▶ Motors without terminal box available with mountings for steel tubes for cable routing.
- ▶ Motors with protection class IP56 – IP65 – IP66.
- ▶ Motors with drainage valves for condensation water.
- ▶ Motors with special bearings.
- ▶ Vibration level of classes A or B, according to EN / IEC 60034-14.
- ▶ Motors with rain or sunroof, water protection panel.
- ▶ Slanted terminal box for increased safety “e” constructions
- ▶ Separate terminal box for separated auxiliary terminals or additional accessory terminals.
- ▶ Model with low sound emission.
- ▶ Higher corrosion protection for tropical climate or applications in marine environments:
 - ❑ exterior paint of mechanical components with epoxy varnish,
 - ❑ protection of interior component (coil and rotor) with protective paint,
 - ❑ rust-proof screws.

Accessories

- ▶ Motors for supply with electronic frequency inverter.
- ▶ Motors with encoder.
- ▶ Motors with external ventilation.

2 Mechanical characteristics

2.1 Setup conditions

The motors can be installed in clear and dusty, moist or chemically aggressive rooms (industry) with temperatures from -20 °C to +40 °C.

	It is required to specify the respective setup conditions in the order.
---	---

Protection classes

First code number:
Degrees of protection for protection against accidental contact and foreign matter

Second code number:
Degree of protection for water protection

IP	Declaration
0	No special protection
1	Protection against firm foreign matter larger than 50 mm (example: accidental contact with the hand)
2	Protection against firm foreign matter larger than 12 mm (example: accidental contact with the fingers)
3	Protection against firm foreign matter larger than 2.5 mm (examples: wires, tools)
4	Protection against firm foreign matter larger than 1 mm (examples: wires, tapes)
5	Protection against dust (harmful dust deposits)
6	Complete protection against dust

IP	Declaration
0	No special protection
1	Protection against horizontally dripping water (condensation)
2	Protection against dripping water at inclinations up to 15°
3	Protection against spray water up to 60° from the vertical axis
4	Protection against splash water from all directions
5	Protection against water jets from a nozzle and from all directions
6	Protection against choppy seas or strong water jets
7	Protection when submerging between 0.15 and 1 m
8	Protection during long-lasting submersion in water under conditions agreed between the manufacturer and user.

2.2 Model for lowest temperatures with stationary heating

Motors that are to be installed in regions with extremely low temperatures must be ordered separately.

The certificates on the explosion safety apply to temperatures up to -50 °C.

The motors equipped with heating elements (electrical resistor heating) maintain a minimum temperature of -20°C when the motor is at a standstill (see table).

	During the operation of the motor, the heating elements must be switched off.
---	---

The standard voltage is 230 V ± 10 %.

Stationary heating

Frame size	For the prevention of condensation water Heating element Min. required power [W]	For use in environments with the temperatures below -20 °C (up to -50 °C) Heating element Min. required power [W]
355M	200	400
355L	235	470
400M	250	500
400L	300	600
450	300	600
450L	350	700
500	385	770
500L	400	800

2.3 Material

	Frame size 355–500
Motor housing, bearing shield, terminal box	Steel
Ventilator hood, rain protection roof	Steel
Fan wheel	Steel
Shaft	Steel C45
Rotor	Copper cage
Coil	Insulation class F
Screws, motor housing, bearing shield, terminal box	Steel 8.8 galvanized or A4-80 UNI EN ISO 3506-1

2.4 Paint

	Frame size 355–500
Paint priming	Components are sand-blasted, clean and free from grease, treated with rust-protection primer
Layer thickness, colour	Top coat with enamel paint, overall 120 µm (other thicknesses on request) RAL 7030 (special colours on request)
Mechanical resistance	Abrasion-resistant, elastic, scratch and impact-resistant
Corrosion resistance	Excellent resistance against water, water steam and saline liquids
Chemical resistance, measurement conditions	Good resistance in chemically aggressive environment

2.5 Shaft ends, balancing, vibrations, noise level and coupling

Shaft ends

The shaft ends are cylinder-shaped and comply with the standards EN 50347 / IEC 60072. As a standard, they are provided with a parallel key and a threaded hole on the front side for the mounting of belt pulleys and couplings.

The parallel keys are included in the delivery of the motor. On request, motors with second shaft ends and/or special shaft end are also available.

Balancing, vibrations

The rotors are dynamically balanced with a half parallel key according to ISO 8821.

The vibration values are within the limits prescribed by the standards EN / IEC 60034-14, Level “A” (N). For special requirements, motors with a vibration level of “B” (R) (reduced) are available.

It must be ensured before assembly that the transmission elements, such as belt pulleys and couplings have been dynamically balanced (full keyway and half key balancing).

Noise level

The noise level values comply with the standards EN / IEC 60034-9. The nominal data include the sound pressure values “L_p” in dB (A) for each motor type.

These values apply to motors in idle run with a frequency of 50 Hz and a tolerance of +3 dB(A). For motors with 60 Hz, the sound pressure values are approx. 4 dB(A) higher than at 50 Hz.

Direct coupling

For a direct coupling of the motor with the driven machine, the shaft axes have to be aligned properly in order to avoid damages or seizing up of the bearings.

The connection with a lamellar coupling or similar coupling types is permissible for all motors but in that case, as well, the axes have to be aligned properly. Special care is required in the assembly of 2-pole motors.

Belt drive

In order to simplify assembly and the adjustment of the belt tension, assembly slides are commonly used on which the motor is mounted.

It has to be checked if the maximum radial stress generated by the belt tension is less than the maximum permissible force specified in the motor data. Belt pulleys and couplings may only be mounted and removed with the tools provided for this purpose.

2.6 Types

The designs of the electrical machines are designated according to EN / IEC 60034-7, Code I (Bracket Value Code II).

Our motors can be delivered as specified in the table depending on the model and frame size.

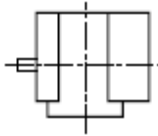
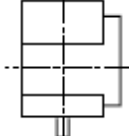
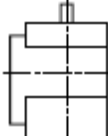
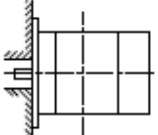
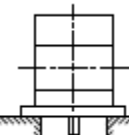
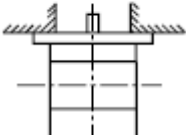
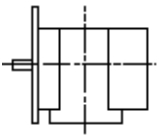
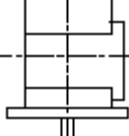
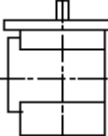
		
IM B3 (IM 1001)	IM V5 (IM 1011)	IM V6 (IM 1031)
		
IM B5 (IM 3001)	IM V1 (IM 3011)	IM V3 (IM 3031)
		
IM B35 (IM 2001)	IM V15 (IM 2011)	IM V36 (IM 2031)



The required model has to be specified in the order, as the design will be adjusted in part to the installation position.

2.7 Belt drive

All data refer to the normal shaft end on the drive end side of motors of the model IM B3 with one rotation speed.

Calculation of the belt pull:

$$F_R = \frac{19120 \cdot P \cdot k}{D_1 \cdot n} \text{ [N]}$$

F_R = radial axial force in N

P = output in kW

n = rotation speed in min^{-1}

D_1 = belt pulley diameter in m

k = pre-tension factor

The pre-tension factor depends on the belt type and it is assumed in approximation as follows:

3...4	for normal flat belts without tension roller
2...2.5	for normal flat belts with tension roller
2.2...2.5	for V-belts

The exact value has to be enquired from the belt manufacturer.

2.8 Terminal boxes

Our series offers the following models:

- ▶ Ex d IIC (Standard model)
- ▶ Ex d e IIC
- ▶ Ex d IIB
- ▶ Ex d e IIB

Available on request:

- ▶ Motors with additional terminal box for auxiliary cables
- ▶ Motors without terminal box and conducted lines

Position of the terminal box and the terminals

The terminal boxes are arranged in the upper area of the housing, the position of the cable inlets can be turned by 90° in four positions.

On horizontally mounted motors, the cable inlets are normally arranged on the right side (viewed from the drive side).

Terminals and protective conductor connection

In the terminal box, maximally 3 power terminals can be arranged. The number of permissible accessory parts depends on the number of the terminals required for the motor and on whether an additional terminal box is provided.

Two additional terminals are required for PTC thermistors. Also, the connection of a stationary heating system requires two terminals.

For PT100 (RTD), 3 or 4 terminals are necessary depending on the chosen type.

The terminal box also contains one protective conductor terminal.

An additional protective conductor terminal is arranged on the motor housing.

Cable inlet thread

The motors are delivered in the series standard with one or two cable inlets that are suitable for explosion-protected cable glands.

For Ex d e motors, also cable glands certified for the protection class Ex e can be used.

The motors equipped with temperature sensors or stationary heating have an additional cable inlet for the connection of these accessory parts.

Cable inlet thread

Frame size	Cable inlet thread	
	Ex d	Ex e
355...500	1(2) x M63 x 1.5	1 x M75 x 1.5

3 Electrical characteristics

3.1 Conditions for rated operation

Output

The output of the other rated characteristics specified in this catalogue refers to the following conditions according to the standard EN / IEC 60034-1:

- ▶ Continuous operation (S1)
- ▶ Frequency 50 Hz
- ▶ Voltage 6000 V (Standard)
- ▶ Ambient temperature of 40 °C
- ▶ Altitude of setup site max. 1000 m absolute

The motors can also be operated in an enhanced ambient temperature and be set up in absolute altitudes of up to 4000 m. In this case, the output will reduce as shown in the table. Alternatively, a bigger motor might be required.

If the full rated output is required as per the selection tables, the coolant temperature has to be reduced according to the table shown on the side.

Altitude of setup site		
2000 m	3000 m	4000 m
32 °C	24 °C	16 °C

Voltage, frequency

As a standard, the motors are designed for operation with the rated voltages and frequencies, as well as the tolerances given in the standard EN / IEC 60034-1. The motors may be operated with the tolerances provided for the normal area of use zone A (voltage $\pm 5\%$, frequency $\pm 2\%$).

The motors can furthermore be used in observation of the requirements according to the standard EN / IEC 60034-1, in areas with limited use zone B (deviations of the voltage of $\pm 10\%$ and of the frequency of $\pm 3\%$).

Starting

The motors have a squirrel-cage rotor that is suitable for the direct online start. The values of the starting and breakdown torque can be found in the tables of the operating data.

Rotation speed

The rotation speeds specified in the data tables refer to 50 Hz and correspond to the synchronous rotation speed less slippage.

Rotation direction

Some of the motors can be operated in both rotation directions. Motors for one rotation direction are typical at bigger motor sizes, higher rotation speed and specific demands regarding noise level. Please clarify at order and see individual technical data.

If the phases in sequences L1, L2, L3 are connected to terminals U1, V1, W1, the motor will rotate clockwise when looking at the shaft end.

The rotation direction can be reversed by reversing two optional phases if applicable.

3.2 Tolerances

In consideration of the manufacturing tolerances and material deviations in the used raw materials, the tolerances for industrial motors according to EN / IEC 60034-1 are permitted for the assured values. The following notes in this regard are included in the standard:

- ▶ An assurance of all or any of the values according to the table is not mandatorily required. Assured values to which permissible deviations are to apply must be expressly stated in the offers. The permissible deviations have to match the table.
- ▶ If there is a permissible deviation only in one direction, the value in the other direction is not limited.

Values for	Tolerance
Efficiency class(η) (for indirect assessment)	-0.15 x (1- η) for $P_N \leq 50$ kW -0.10 x (1- η) for $P_N > 50$ kW
Power factor (cos φ)	$-\frac{1 - \cos \varphi}{6}$, at least 0.02, at most 0.07
Slippage (s) (for rated load in condition at operating temperature)	± 20 % of the assured slippage for $P_N \geq 1$ kW ± 30 % of the assured slippage for $P_N < 1$ kW
Locked rotor current (I_A) (in the intended start switching)	+20 % of the assured locked rotor current without bottom limitation
Locked rotor torque (M_A)	-15 % and +25 % of the assured locked rotor torque (+25 % may be exceeded upon agreement)
Pull-up torque (M_S)	-15 % of the assured value
Tilting moment (M_K)	-10 % of the assured value (after application of this tolerance, M_K/M_N is at least 1.6)
Inertia moment (J)	± 10 % of the assured value

3.3 Insulation and heating

The insulation of the motors corresponds to thermal classes F according to EN / IEC 60034-1:

- ▶ mica isolated copper wire
- ▶ additional insulation materials on polyester or glass fiber basis
- ▶ Vacuum pressure impregnation (VPI) with resin

The table shown on the side specifies the average heating (ΔT) and maximum temperatures. The hottest points of the coil (T_{max}) according to the thermal classes of the standard EN / IEC 60034-1.

Class:	ΔT	T_{max}
B	80 K	130 °C
F	105 K	155 °C
H	125 K	180 °C

3.4 Circuitry

Star circuit

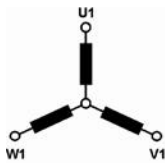

The stator windings star point is internally connected.

Phase current and voltage are: $I_{ph} = I_N$; $U_{ph} = U_N / \sqrt{3}$

where I_N is the rated current and U_N is the rated mains voltage.

3.5 Motor protection

The selection of a thermal protection for the motors should be made according to the given operating conditions. The motors can be protected through current-dependent motor circuit breakers or overcurrent relays and temperature sensors.

Motor protection possible as follows:

- ▶ Motor circuit breaker with bi-metal trigger
- ▶ Thermistor protection with resistor temperature sensors (PTC) in the stator winding in connection with the triggering device (if applicable, additional motor circuit breaker)
- ▶ Resistance thermometer for monitoring of the coil or bearing temperature PT100 Ω

If a motor protection is required, bi-metal switches or resistor temperature sensors (PTC) can be installed.

Mode of functioning of the bi-metal temperature sensors

Ti Switching temperature

Tr Reset temperature

Type N/O (normally open)

Type N/C (normally closed)

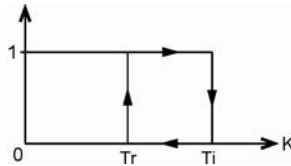
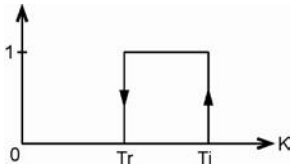

Mode of functioning of the resistor temperature sensors (PTC type)

Ti Switching temperature

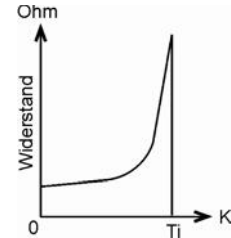

Circuitry examples

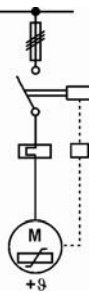
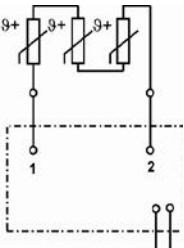
Protection measure	Protection against...
 <p>Motor circuit breaker with thermal and electromagnetic overcurrent trigger</p>	<ul style="list-style-type: none"> ▶ Overload in continuous operation ▶ Blocked rotor ▶ Not for operation with frequency converter according to EN / IEC 60079-14
 <p>Protection with overcurrent relay Thermistor protection and fuse</p>	<p>In operation, protection against:</p> <ul style="list-style-type: none"> ▶ Overload in continuous operation ▶ Long start-up and braking processes ▶ High switching frequency <p>In case of failure, protection against:</p> <ul style="list-style-type: none"> ▶ Obstruction of the cooling ▶ Increased coolant temperature ▶ One-phase run ▶ Frequency fluctuations ▶ Blocked rotor
 <p>Resistor temperature sensor with trigger device</p>	<p>In operation, protection against:</p> <ul style="list-style-type: none"> ▶ Overload in continuous operation ▶ Long start-up and braking processes ▶ High switching frequency <p>In case of failure, protection against:</p> <ul style="list-style-type: none"> ▶ Obstruction of the cooling ▶ Increased coolant temperature ▶ One-phase run ▶ Frequency fluctuations ▶ Blocked rotor

EN / IEC 60079-14 must be observed.

3.6 Alternating current motors with cage rotors in operation on the frequency inverter

The motors built specifically for this purpose, with ignition protection classes “d” or “d e”, can also be operated in classified areas with supply from an electronic frequency inverter. EN / IEC 60079-14 must be observed.

If Ex d motors with frequency inverters are used, the following factors must also be considered in addition to the common selection criteria:

- ▶ Motors operated with frequency inverters do not have a pure sine-wave voltage (or current). This fact leads to rising dissipations, vibrations and noise level of the motor.
- ▶ When using frequency inverters, the rotation speed of the motors can differ significantly from the rated rotation speed shown on the type plate. Rotation speeds exceeding the value shown on the type plate must be reconcilable with the motor and the motor-load-machine proposition.
- ▶ The operating duration with a rotation speed higher than 3600 min^{-1} must not be above 10 % of the total work cycle of the motor in order to assure an appropriate lifetime.
- ▶ Maxim initial inverter voltage 6000 V with peak voltages of $\hat{U} \leq 12.2 \text{ kV}$ and $d/dt \geq 1 \mu\text{s}^{-1}$. For higher initial inverter voltages or loads, a special insulation is required.
- ▶ The motors non-drive bearing is insulated against shaft currents.
- ▶ An approved and functionally tested temperature monitoring device needed, that separate the motor from the supply in case of over-temperature.

Torque limits for operation with frequency inverter (IC411: self-ventilated; IC416: with external ventilation)

2-pole motors

Frame size 355

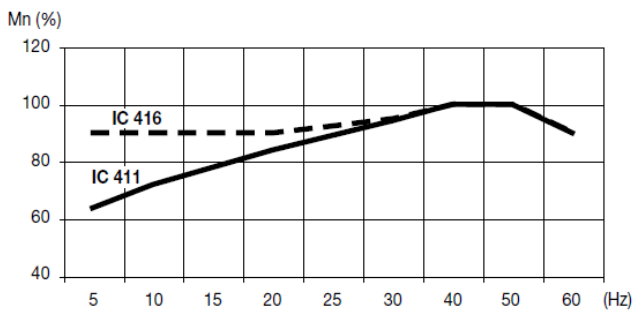

Frame sizes 400, 450, 500

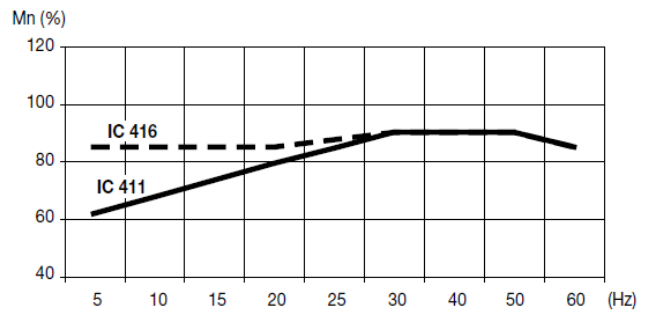

4-, 6-pole motors

Frame size 355

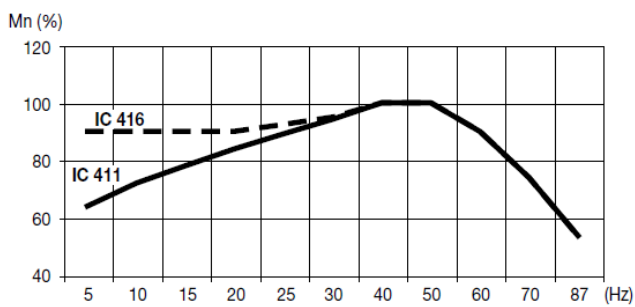

Frame sizes 400, 450, 500

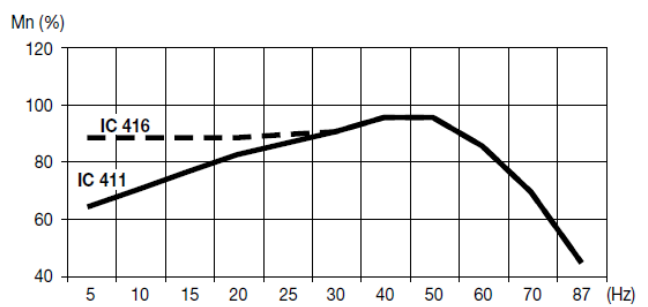

4 Operating data

The technical data specified in the following apply to the models with Ex d IIC/IIB and Ex d e IIC/IIB.

4.1 Overview

Type *	Frame size	Rated output [kW]		
		2-pole	4-pole	6-pole
DDOR355M	355	160	160	-
DDOR355M	355	200	200	-
DDOR355M	355	250	250	200
DDOR355L	355	315	315	250
DDOR355L	355	355	355	315
DDOR400M	400	400	400	-
DDOR400M	400	-	450	-
DDOR400L	400	450	500	355
DDOR400L	400	500	560	400
DDOR400L	400	-	-	450
DDOR450M	450	560	-	-
DDOR450L	450	630	630	500
DDOR450L	450	710	710	560
DDOR450L	450	-	800	630
DDOR500M	500	-	900	710
DDOR500M	500	800	1000	800
DDOR500L	500	900	1250	900
DDOR500L	500	1000	-	1000

* The type designations change depending on the ignition protection class as follows:

- ▶ Ex d IIC: CDDOR
- ▶ Ex d IIB: BDDOR
- ▶ Ex d e IIC: CDEDOR
- ▶ Ex d e IIB: BDEDOR

4.2 Bearings

Bearing attribution (standard design)

Grooved ball bearing and cylindrical roller bearings according to ISO 15 (DIN 625).

Frame size	Number of poles	Drive side	Non-drive side
355	2 (hor.)	6316 C3	6316 C3
	2 (vert.)	6316 C3	7216 BM
355	4,6 (hor.)	6322 C3	6316 C3
	4,6 (vert.)	6322 C3	7216 BM
400	2 (hor.)	6317 C3	6317 C3
	2 (vert.)	6217 C3	7217 BM
400	4,6 (hor.)	6324 C3	6319 C3
	4,6 (vert.)	6324 C3	7219 BM
450	2 (hor.)	6217 C3 + NU 217 C3	NU217 C3
	2 (vert.)	6217 C3	7320 BM
450	4,6 (hor.)	6226 C3 + NU 324 C3	NU324 C3
	4,6 (vert.)	6324 C3	7320 BM
500	2 (hor.)	6219 C3 + NU 219 C3	NU 219 C3
	2 (vert.)	6219 C3	7322 BM
500	4 (hor.)	6228 C3 + NU 326 C3	NU 326 C3
	4 (vert.)	6226 C3	7322 BM
500	6 (hor.)	6230 C3 + NU 328 C3	NU 328 C3
	6 (vert.)	6228 C3	7322 BM

Standard design of bearings

(other arrangements on request)

Frame size	Bearing Drive side	Bearing on non-drive side	Spring element
355...500	Fixed bearing	Floating bearing	Non-drive side (hor.) Drive side(vert.)



The motor's non-drive side bearing is insulated against shaft currents.

Maximum permissible axial forces without additional radial forces

The values apply to 50 Hz and to minimum 50,000 hours assumed bearing life. For operation with 60 Hz, the values must be reduced by 10% (with effect from additional radial forces, a query is required depending on the direction of force).

Horizontal shaft

Frame size	Permissible axial forces (pressure or pull) [N]		
	Grooved ball bearing		
	3000 min ⁻¹	1500 min ⁻¹	1000 min ⁻¹
355	4036	5650	7520
400	4973	8103	9767
450	7063	11575	13673
500	8842	16580	18365

Vertical shaft downward or upward

Frame size	Permissible axial forces (pressure or pull) [N]					
	Angular contact ball bearings (downward)			Deep groove ball bearings (upward)		
	3000 min ⁻¹	1500 min ⁻¹	1000 min ⁻¹	3000 min ⁻¹	1500 min ⁻¹	1000 min ⁻¹
355	4250	5312	5666	2825	3955	5264
400	4825	7750	8266	3481	5673	6836
450	10150	12687	13533	5504	8102	9571
500	12000	15000	16000	6188	11606	12855

Permissible radial forces

The values apply to 50 Hz and to minimum 50,000 hours assumed bearing life. For operation with 60 Hz, the values must be reduced by 6 %

If the radial force is applied between points X₀ and X₂, the permissible force F_R can be calculated from the following formula: $F_R = F_{X_0} - X/E (F_{X_0} - F_{X_2})$, where E = length of shaft extension in basic version.

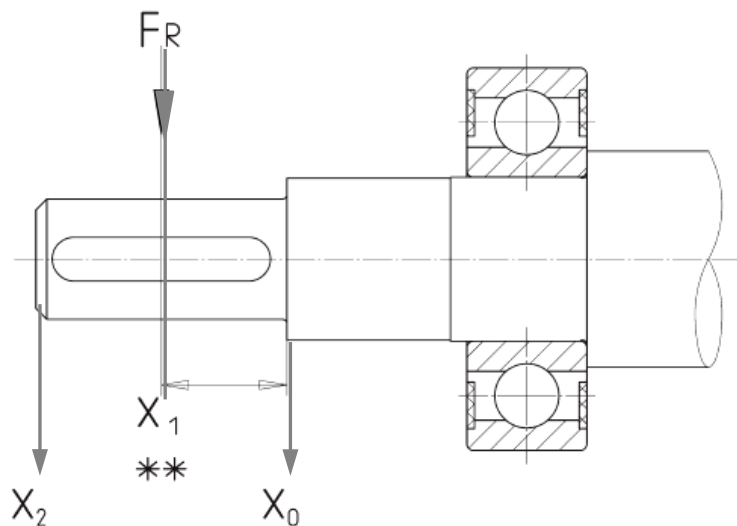

Frame size	Force impact point	Permissible radial forces [N]					
		Grooved ball bearing			Cylinder roller bearing		
		3000 min ⁻¹	1500 min ⁻¹	1000 min ⁻¹	3000 min ⁻¹	1500 min ⁻¹	1000 min ⁻¹
355	X ₀	2830	8830	9490	–	–	–
	X ₂	1306	3210	3452	–	–	–
400	X ₀	2530	8140	8580	–	–	–
	X ₂	1046	2960	3118	–	–	–
450	X ₀	-	-	-	2940	6420	6870
	X ₂	-	-	-	1216	2334	2497
500	X ₀	-	-	-	4170	36000	42750
	X ₂	-	-	-	1725	13109	15545

4.3 Technical data of standard motors

Type	Frame size	Rating data for mains operation							With direct activation			Rotor inertia J [kgm ²]	Weight [kg]
		Rated output P _N [kW]	Rated rotation speed n _N [min ⁻¹]	Rated torque M _N [Nm]	Efficiency class EN 60034-2-1:2014			Power factor cos φ	Locked rotor current to rated current I _A /I _N	Locked rotor torque to rated torque M _A /M _N	Breakdown torque to rated torque M _k /M _N		
					η [%]								
					100%	75%	50%						

Helmke flameproof

3000 min⁻¹ (2-pole)

DDOR355M-02-5	355	160	2980	513	96,5	95.4	94.5	0,88	6.0	0.7	2,3	2,7	2250
DDOR355M-02-5	355	200	2980	642	95,7	95.6	95	0,88	5,5	0.7	2	3	2350
DDOR355M-02-5	355	250	2982	801	96,1	96	95.2	0,88	6	0.7	2,3	3,5	2500
DDOR355L-02-5	355	315	2980	1011	96,5	96.4	96	0,89	6	0.8	2,2	4,25	2850
DDOR355L-02-5	355	355	2982	1138	96,6	96.5	96	0,87	6	0.8	2,3	4,5	3000
DDOR400M-02-5	400	400	2983	1282	96,3	96.2	95.4	0,9	6	0.8	2,2	6	3300
DDOR400L-02-5	400	450	2984	1442	96,4	96.3	95.5	0,9	6,5	0.9	2,3	6,5	3450
DDOR400L-02-5	400	500	2985	1601	96,5	96.4	95.8	0,9	6,5	0.9	2,4	6,5	3650
DDOR450M-02-5	450	560	2985	1794	97	96.8	96.3	0,91	6	0.8	2,2	13	4650
DDOR450L-02-5	450	630	2986	2017	97,1	96.9	96.5	0,92	6,5	0.8	2,2	14,25	5000
DDOR450L-02-5	450	710	2986	2273	97,1	97	96.6	0,92	6,5	0.9	2,3	16	5350
DDOR500M-02-5	500	800	2983	2564	96,2	96	95	0,92	6	0.8	2,2	34,5	6300
DDOR500L-02-5	500	900	2982	2885	96,3	96.2	95.5	0,92	6	0.8	2,2	39	6850
DDOR500L-02-5	500	1000	2984	3204	96,6	96.4	95.7	0,92	6,5	0.8	2,3	41	7100

Type	Frame size	Rating data for mains operation						With direct activation			Rotor inertia J [kgm ²]	Weight [kg]	
		Rated output P _N [kW]	Rated rotation speed n _N [min ⁻¹]	Rated torque M _N [Nm]	Efficiency class EN 60034-2-1:2014			Power factor cos φ	Locked rotor current to rated current I _A /I _N	Locked rotor torque to rated torque M _A /M _N			Breakdown torque to rated torque M _k /M _N
					η [%]	100%	75%						

Helmke flameproof

1500 min⁻¹ (4-pole)

DDOR355M-04-5	355	160	1490	1027	94,5	94	92,4	0,83	6,5	0,9	2,3	6,25	2200
DDOR355M-04-5	355	200	1490	1283	94,8	94,3	93	0,82	6,5	1	2,4	7,25	2370
DDOR355M-04-5	355	250	1490	1604	95,3	95	93,8	0,83	6,5	0,9	2,3	8,75	2650
DDOR355L-04-5	355	315	1490	2021	95,7	95,5	94,5	0,84	6,5	1	2,3	10	2870
DDOR355L-04-5	355	355	1490	2278	95,8	95,7	94,8	0,84	6,5	1	2,3	11	3150
DDOR400M-04-5	400	400	1490	2566	96	95,8	95	0,85	6,2	0,9	2,2	12,5	3350
DDOR400M-04-5	400	450	1490	2887	96,2	96	95,2	0,85	6,5	1	2,3	13,5	3570
DDOR400L-04-5	400	500	1490	3208	96,3	96,1	95,3	0,85	6,8	1,1	2,3	14,5	3750
DDOR400L-04-5	400	560	1490	3593	96,4	96,2	95,5	0,85	6,8	1,1	2,4	15,5	3970
DDOR450L-04-5	450	630	1487	4050	96	95,8	95	0,88	6,5	1	2,1	31	4750
DDOR450L-04-5	450	710	1488	4562	96,1	96	95,3	0,88	6,7	1,1	2,2	34	5100
DDOR450L-04-5	450	800	1488	5140	96,3	96,2	95,5	0,88	6,8	1,2	2,2	36	5370
DDOR500M-04-5	500	900	1491	5771	96,3	96,2	95,3	0,88	6,3	0,9	2	58	6400
DDOR500M-04-5	500	1000	1491	6412	96,5	96,3	95,5	0,89	6,5	0,9	2	63	6850
DDOR500L-04-5	500	1250	1491	8015	96,7	96,6	96	0,89	6,7	1	2,1	69	7300

Type	Frame size	Rating data for mains operation						With direct activation			Rotor inertia J [kgm ²]	Weight [kg]	
		Rated output P _N [kW]	Rated rotation speed n _N [min ⁻¹]	Rated torque M _N [Nm]	Efficiency class EN 60034-2-1:2014			Power factor cos φ	Locked rotor current to rated current I _A /I _N	Locked rotor torque to rated torque M _A /M _N			Breakdown torque to rated torque M _k /M _N
					η [%]	75%	50%						

Helmke flameproof

1000 min⁻¹ (6-pole)

DDOR355M-06-5	355	200	991	1929	94,2	93,7	92,2	0,8	5,5	0,9	2	13,5	2800
DDOR355L-06-5	355	250	991	2412	94,6	94,2	92,8	0,8	5,5	0,9	2	16	3000
DDOR355L-06-5	355	315	991	3039	95	94,6	93,4	0,8	5,5	0,9	2	18	3300
DDOR400L-06-5	355	355	992	3421	94,8	94,6	93,3	0,8	5,3	0,8	2	26	3900
DDOR400L-06-5	400	400	992	3855	95	94,7	93,6	0,8	5,3	0,8	2	27	4150
DDOR400L-06-5	400	450	992	4337	95,3	95	93,8	0,8	5,5	0,8	2	28,5	4320
DDOR450L-06-5	400	500	992	4819	95,2	95	93,8	0,85	5,5	0,8	2	49	5250
DDOR450L-06-5	400	560	993	5391	95,4	95,1	94	0,85	6	0,9	2,2	52	5470
DDOR450L-06-5	450	630	993	6065	95,6	95,4	94,4	0,85	5,7	0,8	2	55	5750
DDOR50ML-06-5	450	710	994	6829	95,7	95,3	94,1	0,84	6,8	1	2,4	103	6500
DDOR500M-06-5	450	800	994	7694	96	95,8	94,5	0,85	6,8	1	2,4	111	6850
DDOR500L-06-5	500	900	994	8656	96,1	95,8	94,8	0,85	6,8	1	2,4	118,5	7200
DDOR500L-06-5	500	1000	994	9618	96,3	96	95	0,85	6,8	1,1	2,4	126,5	7550

4.4 Dimensions of motors with frame sizes 355–500 (standard design)

Model IM 1001 (B3)

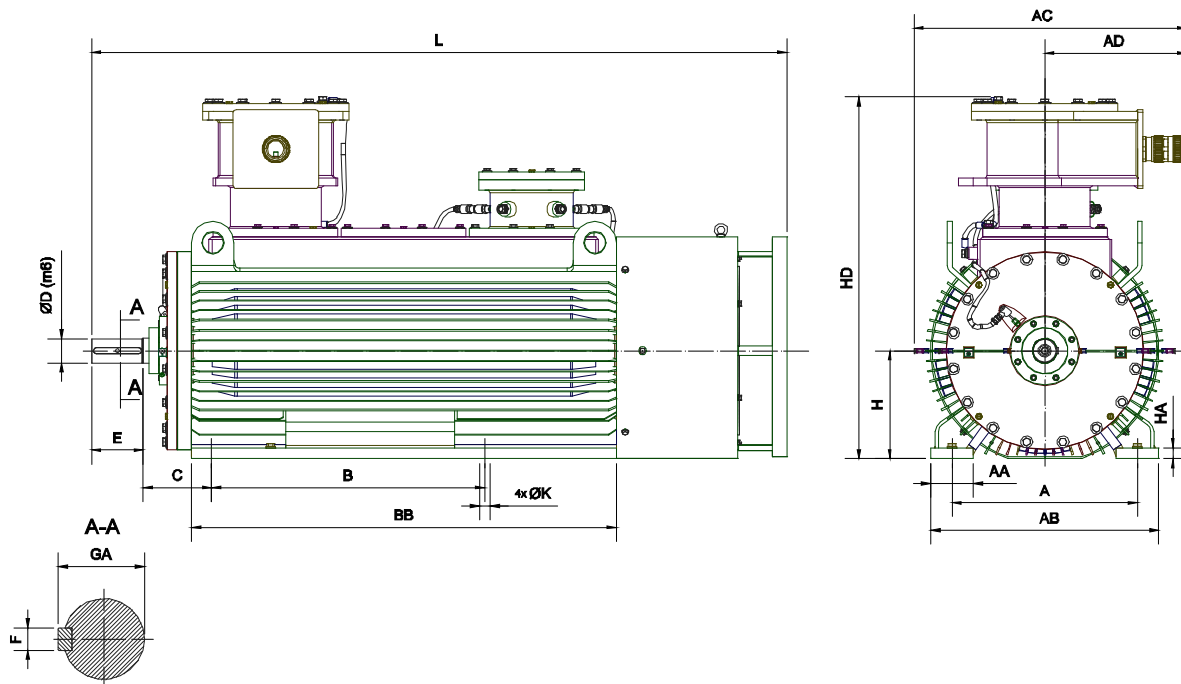

Type	Frame size	Num ber of poles	Dimensions according to IEC [mm]											
			H	A	B	C	AB	BB	HD	AC	AD	HA	K	L
			Dimensions according to DIN [mm]											
			h	b	a	w1	f	e	m1	g	v	c	s	k
DDOR355M-02-5	355	2	355	610	900	254	700	1250	1400	910	450	30	35	1950
DDOR355L-02-5	355	2	355	610	1120	254	700	1450	1400	910	450	30	35	2150
DDOR355M-04(6)-5	355	4-6	355	610	900	254	700	1250	1400	910	450	30	35	1950
DDOR355L-04(6)-5	355	4-6	355	610	1120	254	700	1450	1400	910	450	30	35	2150
DDOR400M-02-5	400	2	400	710	1120	280	840	1450	1460	930	450	30	35	2180
DDOR400L-02-5	400	2..	400	710	1250	280	840	1600	1460	930	450	30	35	2330
DDOR400M-04(6)-5	400	4-6	400	710	1120	280	840	1450	1460	930	450	30	35	2180
DDOR400L-04(6)-5	400	4-6	400	710	1250	280	840	1600	1460	930	450	30	35	2330
DDOR450M-02-5	450	2.	450	800	1120	315	950	1450	1560	980	450	40	42	2340
DDOR450L-02-5	450	2	450	800	1250	315	950	1650	1560	980	450	40	42	2540
DDOR450M-04(6)-5	450	4-6	450	800	1120	315	950	1450	1560	980	450	40	42	2340
DDOR450L-04(6)-5	450	4-6	450	800	1250	315	950	1650	1560	980	450	40	42	2540
DDOR500M-02-5	500	2	500	850	1250	355	1020	1650	1670	1030	450	40	42	2540
DDOR500L-02-5	500	2	500	850	1400	355	1020	1750	1670	1030	450	40	42	2640
DDOR500M-04(6)-5	500	4-6	500	850	1250	355	1020	1650	1670	1030	450	40	42	2580
DDOR500L-04(6)-5	500	4-6	500	850	1400	355	1020	1750	1670	1030	450	40	42	2680

Type	Frame size	Number of poles	Dimensions according to IEC [mm]					
			AA	D	E	F	GD	GA
			Dimensions according to DIN [mm]					
			n	d	l	u		t
DDOR355M-02-5	355	2	120	70	140	20	12	74.5
DDOR355L-02-5	355	2	120	70	140	20	12	74.5
DDOR355M-04(6)-5	355	4-6	120	100	210	28	16	106
DDOR355L-04(6)-5	355	4-6	120	100	210	28	16	106
DDOR400M-02-5	400	2	150	80	170	22	14	85
DDOR400L-02-5	400	2..	150	80	170	22	14	85
DDOR400M-04(6)-5	400	4-6	150	110	210	28	16	116
DDOR400L-04(6)-5	400	4-6	150	110	210	28	16	116
DDOR450M-02-5	450	2.	225	80	170	22	14	85
DDOR450L-02-5	450	2	225	80	170	22	14	85
DDOR450M-04(6)-5	450	4-6	225	110	210	28	16	116
DDOR450L-04(6)-5	450	4-6	225	110	210	28	16	116
DDOR500M-02-5	500	2	225	90	170	25	14	95
DDOR500L-02-5	500	2	225	90	170	25	14	95
DDOR500M-04-5	500	4	225	120	210	28	16	127
DDOR500L-04-5	500	4	225	120	210	28	16	127
DDOR500M-06-5	500	6	225	130	250	32	18	137
DDOR500L-06-5	500	6	225	130	250	32	18	137

5 Mechanical execution and variants

5.1 Standard machine design

Ex d – IC 411 – Cross section and 3D view

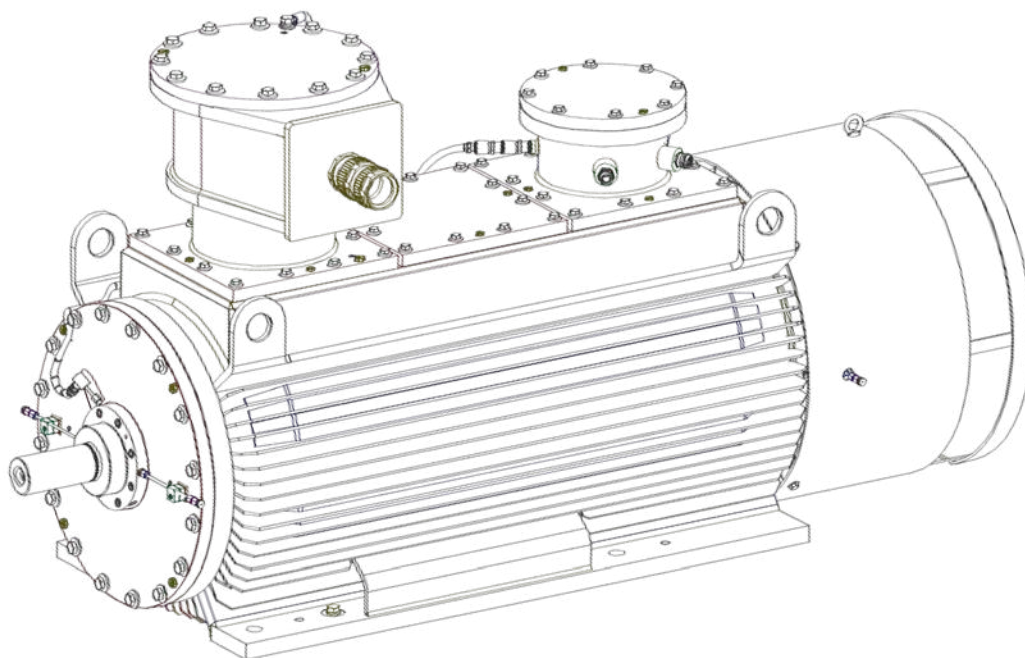
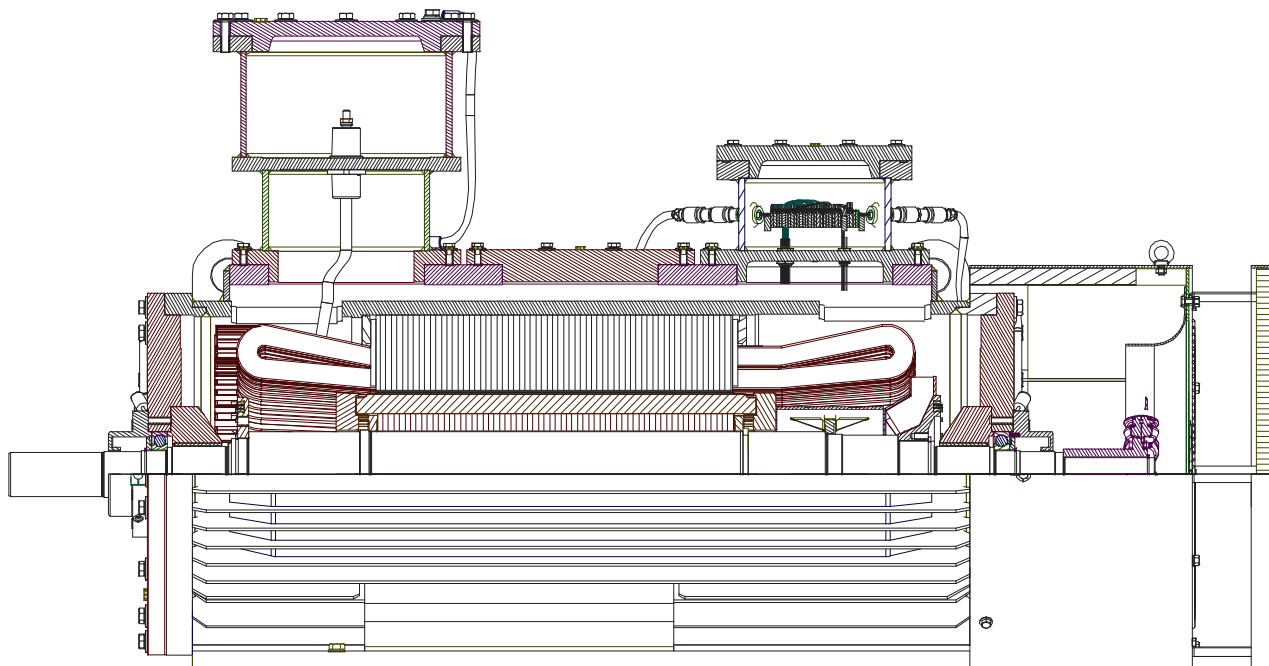

Ex d e – IC411 – Cross section and 3D view

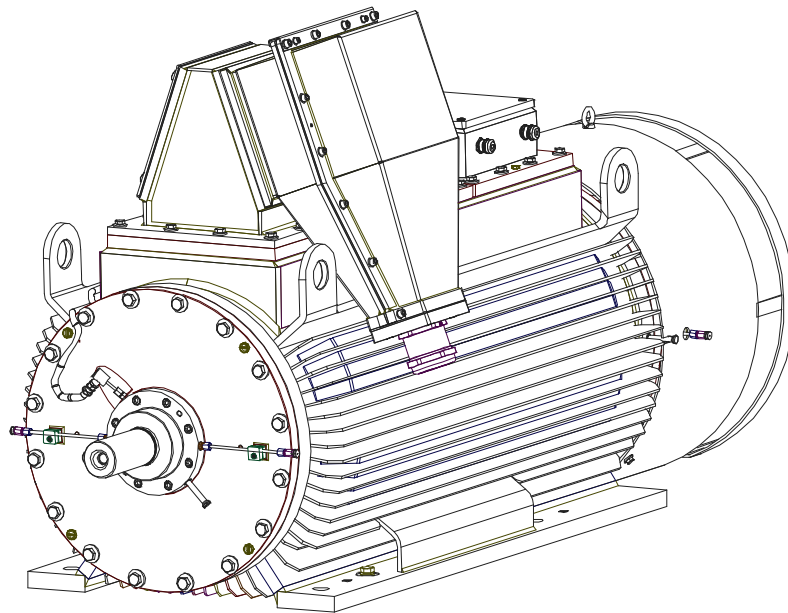
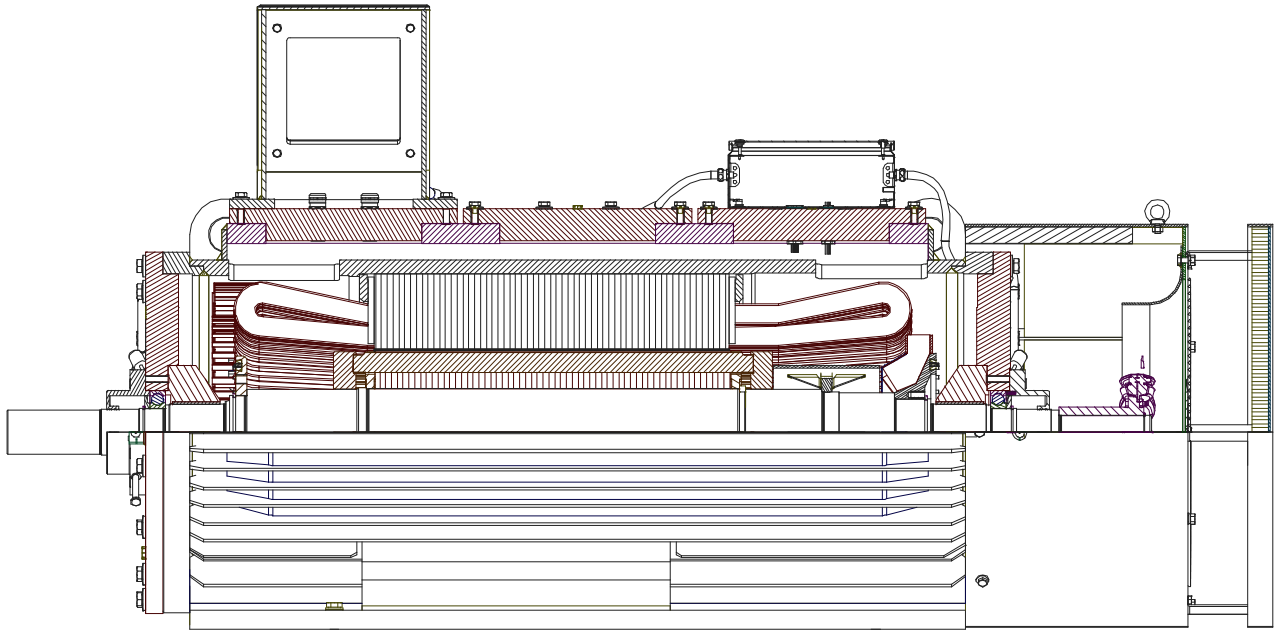

5.2 Terminal box versions

Main terminal box Ex d – Auxiliary terminal box Ex d

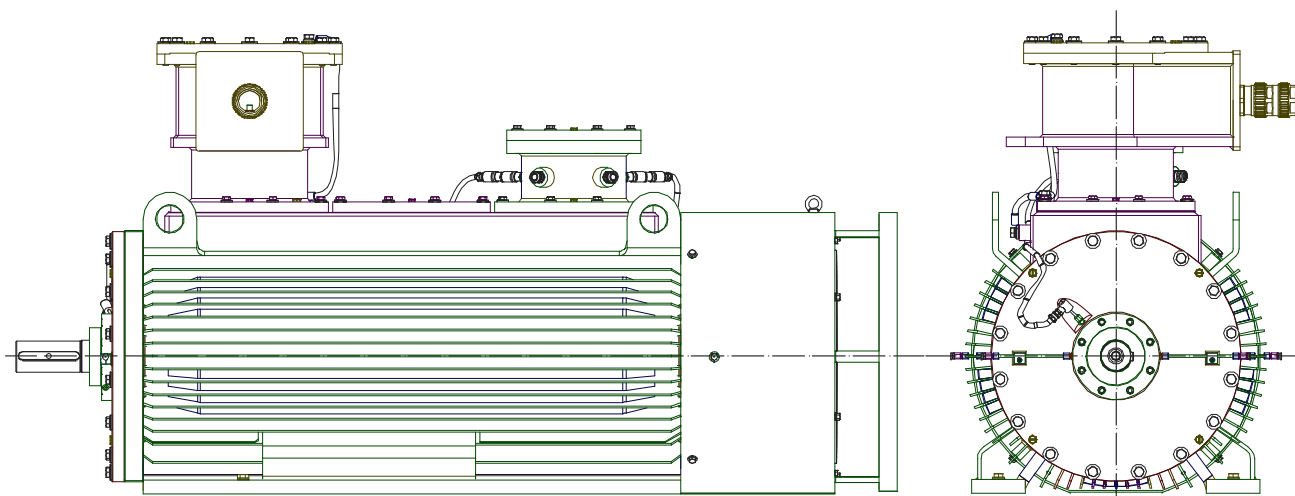

Main terminal box Ex d – Two auxiliary terminal boxes Ex d

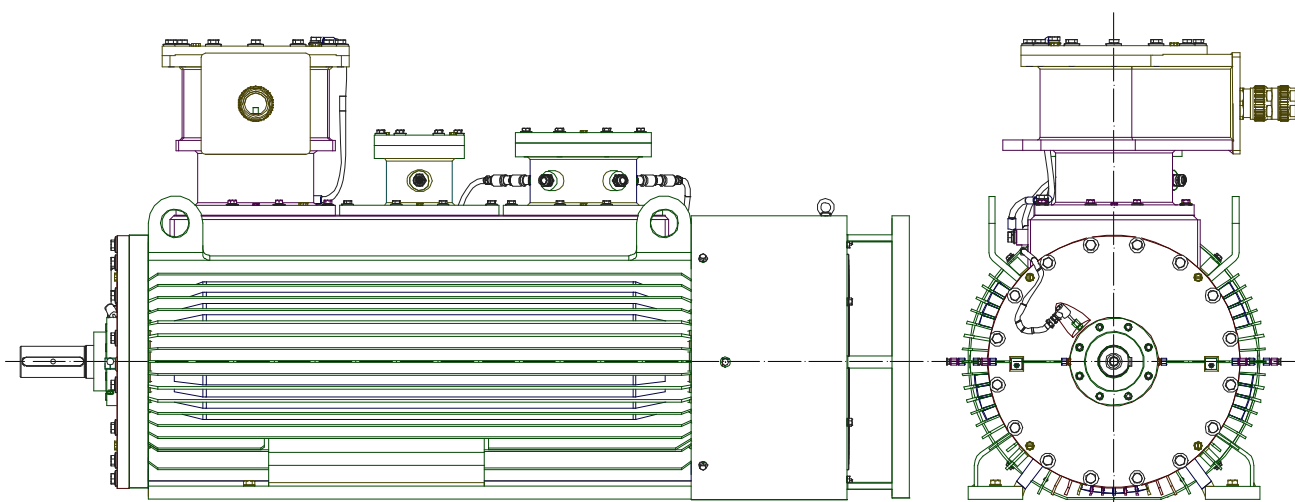

Main terminal box Ex d – Auxiliary terminal box Ex e

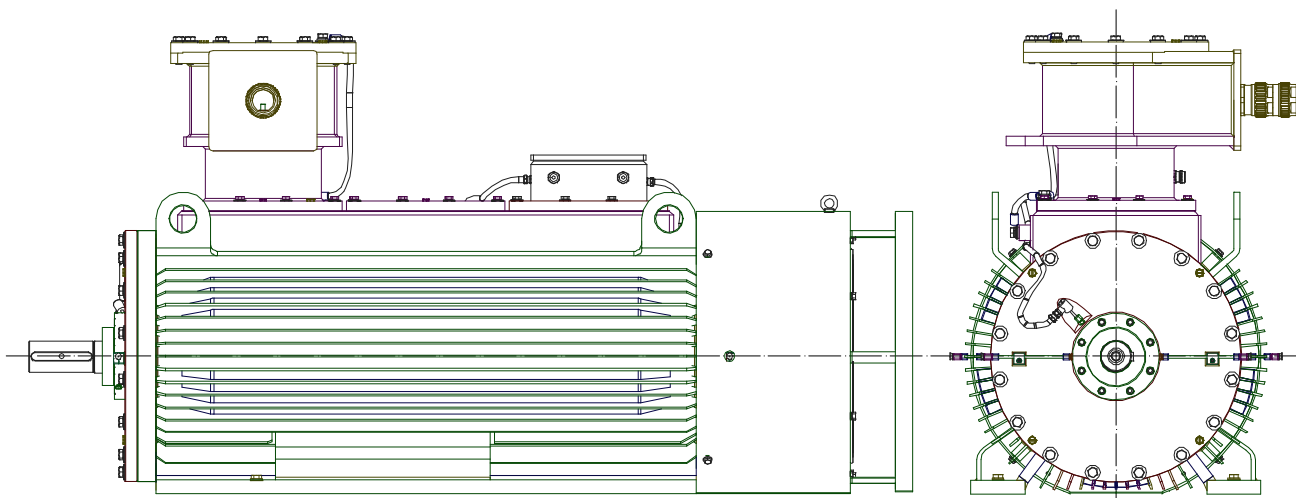

Main terminal box Ex e – Auxiliary terminal box Ex e

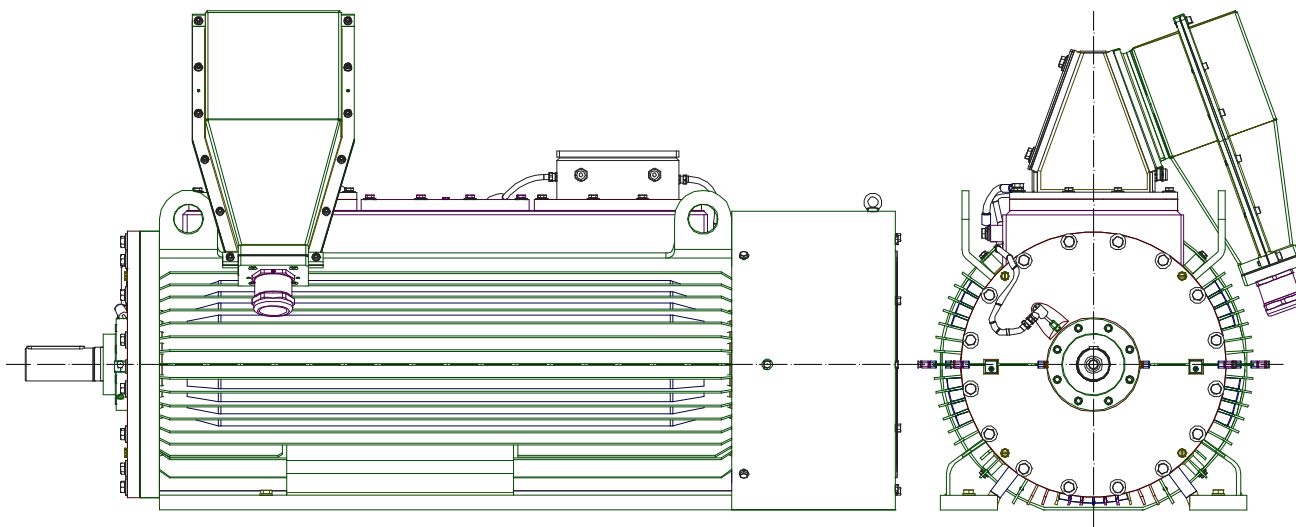

Main terminal box Ex e – Auxiliary terminal box Ex e

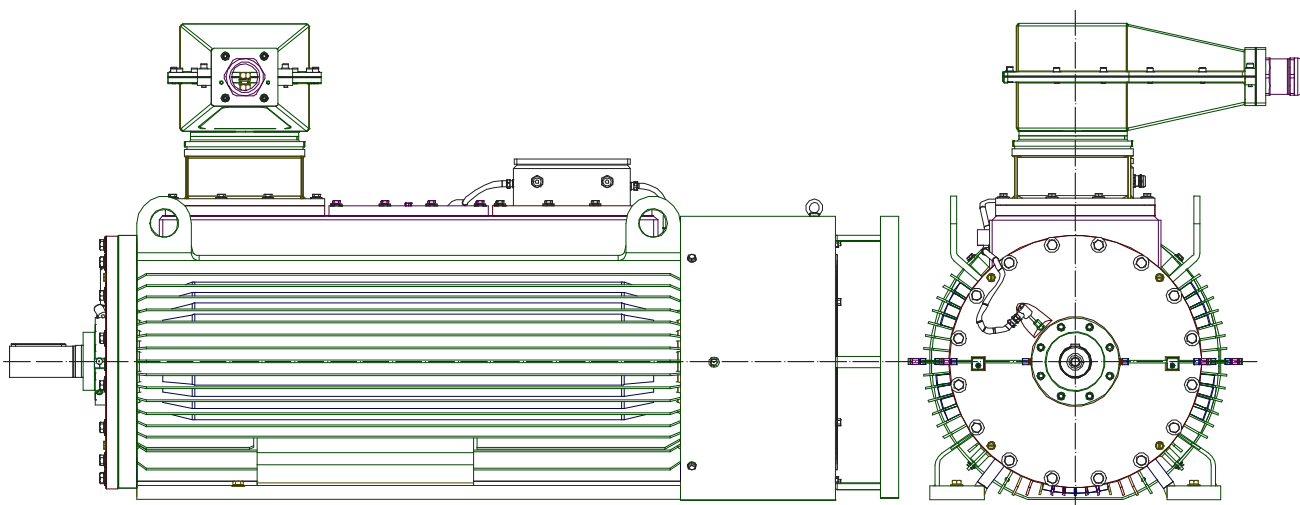

Two main terminal boxes Ex e – Two auxiliary terminal boxes Ex e

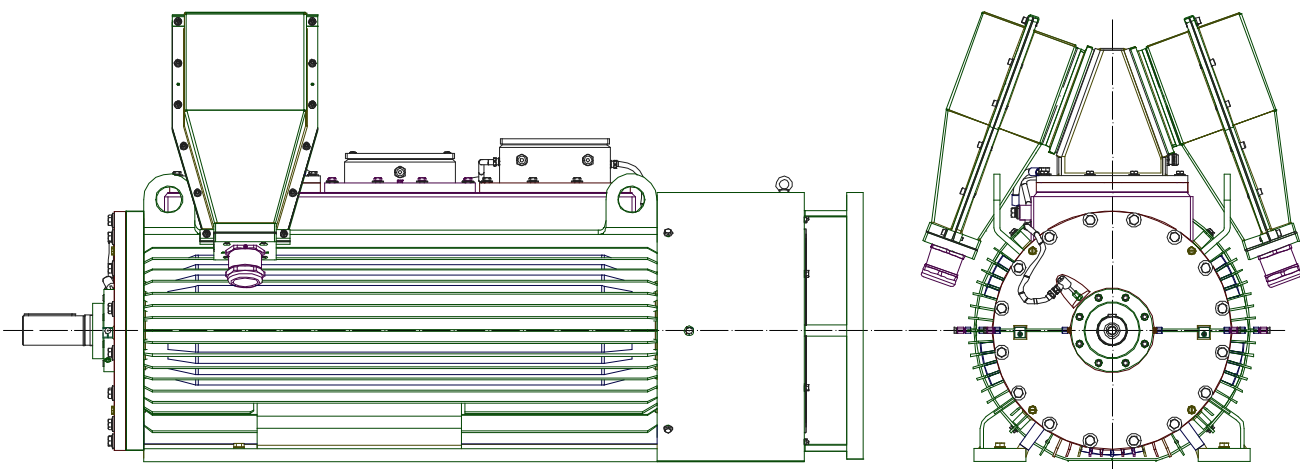

5.3 Customized designs

IM B3 – IC 416 – Variant with forced ventilation – Frame size 500

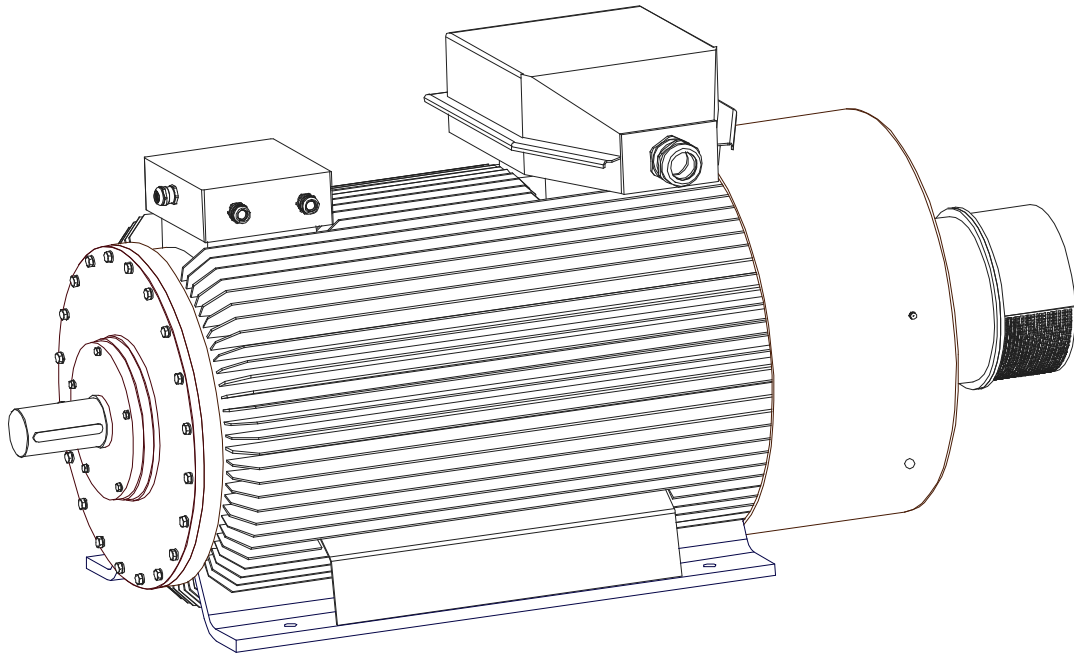

IM B3 – IC 411 – Variant with sleeve bearings and angular Ex d terminal boxes – Frame size 500

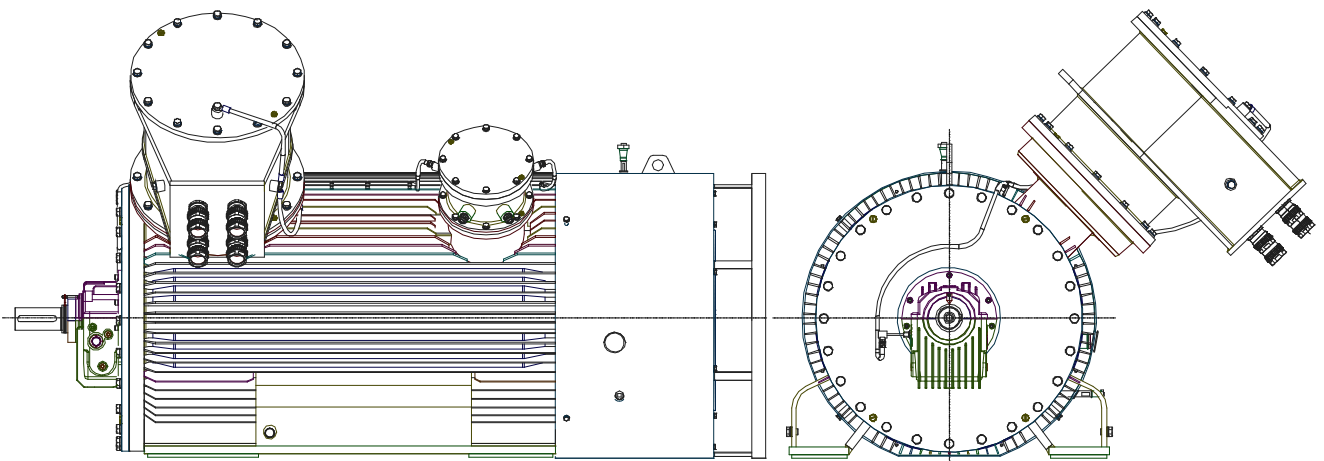

IM B3 – IC 511 – Variant with higher power rating – Frame size 710

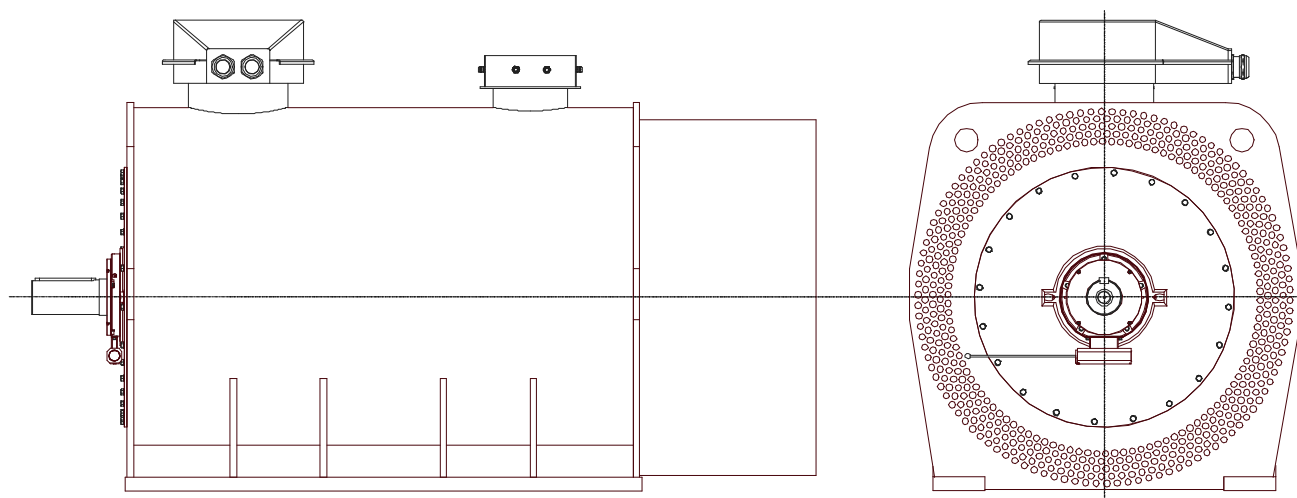

IM B3 – IC 511 – Variant with higher power rating and reduced shaft height – Frame size (shaft height) 425

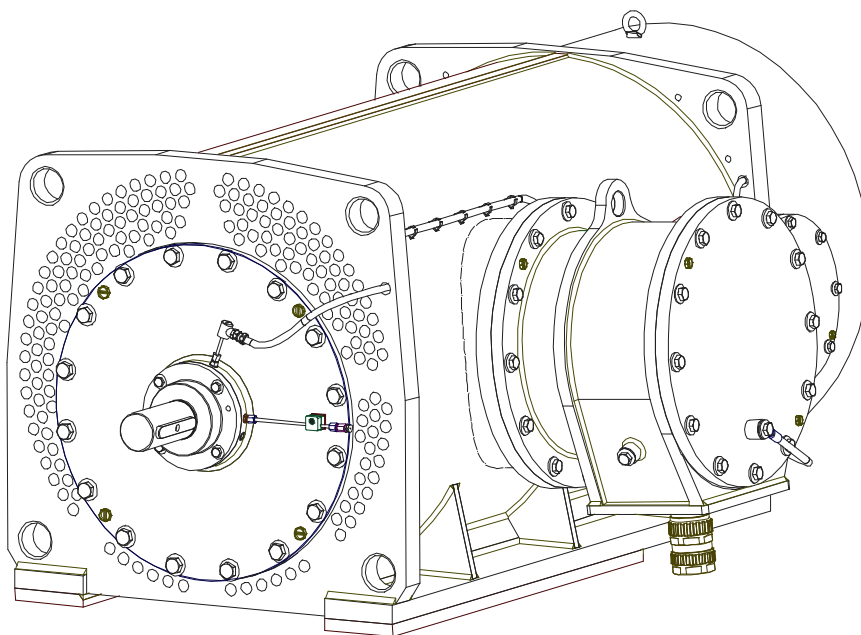

IM V1 – IC 411 – Variant for vertical application, flange and shaft at lower side – Frame size 560

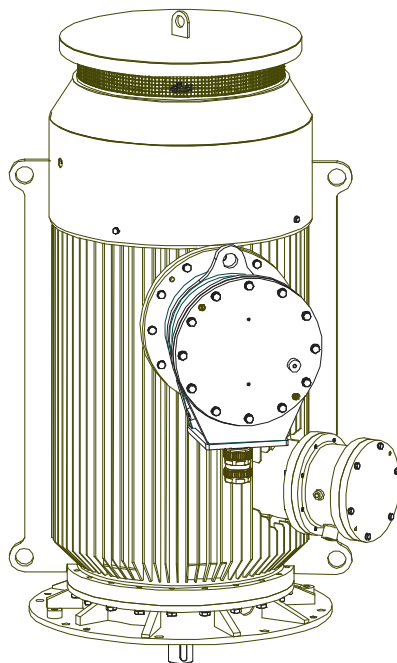

IM V2 – IC 511 – Variant for vertical application, flange at lower side, shaft at upper side – Frame size 710

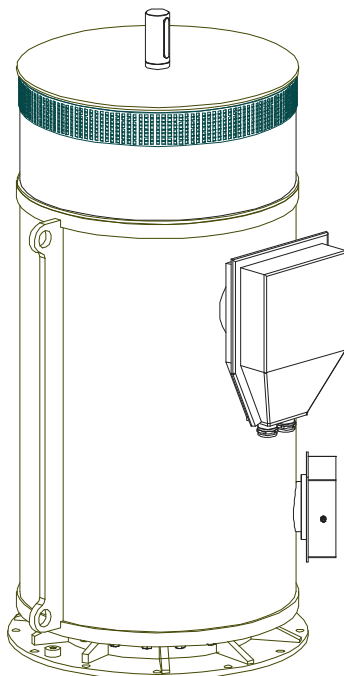

6 Spare parts

Nr.	Designation	Nr.	Designation
1	Motor housing	14	External cover
2	Wounded stator	15	Shaft
3	Terminal box	16	Rotor
4	Terminal box cover	17	Bearing NDE
5	Auxiliary terminal box	18	End shield NDE
6	Auxiliary terminal box cover	19	External ring
7	Space heater terminal box	20	Safety washer
8	Space heater terminal box cover	21	Safety nut
9	Bearing DE	22	External cover
10	End shield DE	23	External fan
11	External ring	24	Fan hood
12	Safety washer	25	Bearing RTD
13	Safety nut		

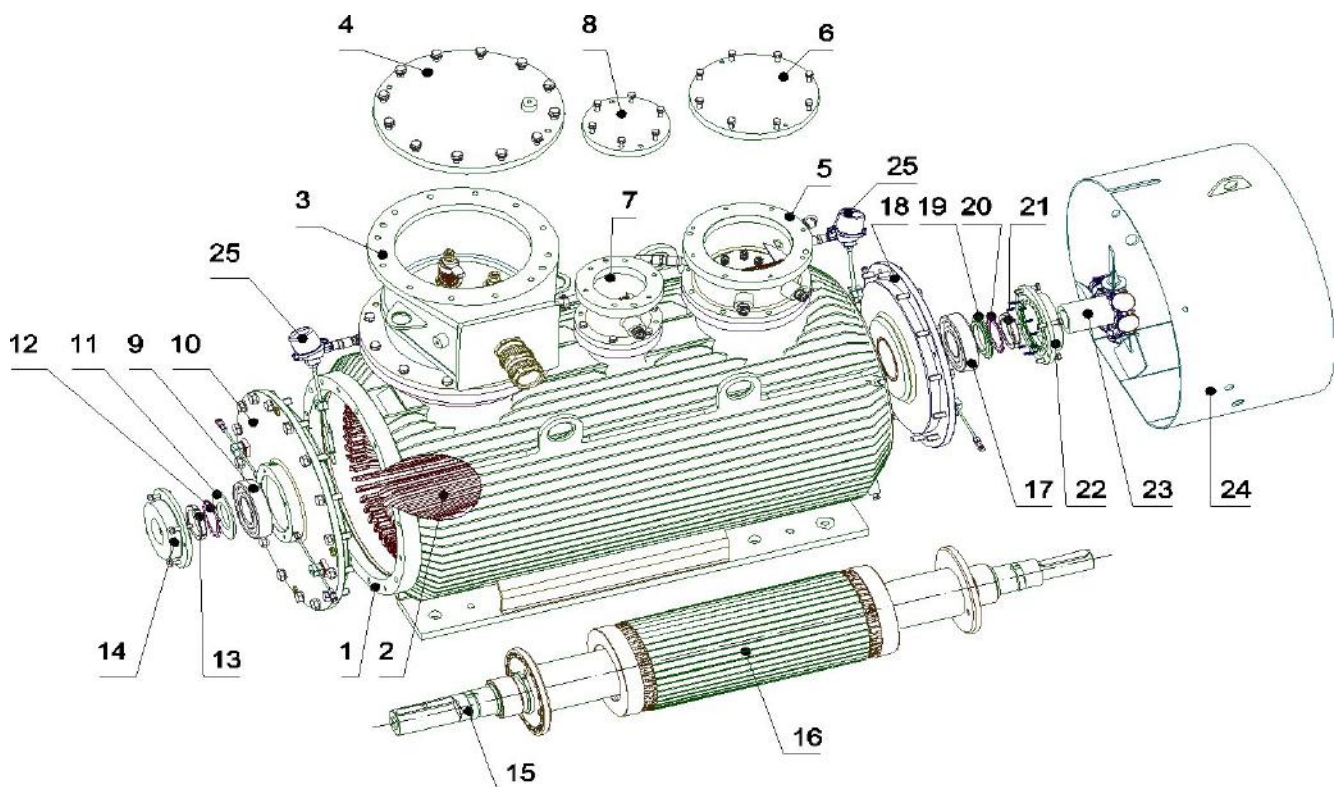

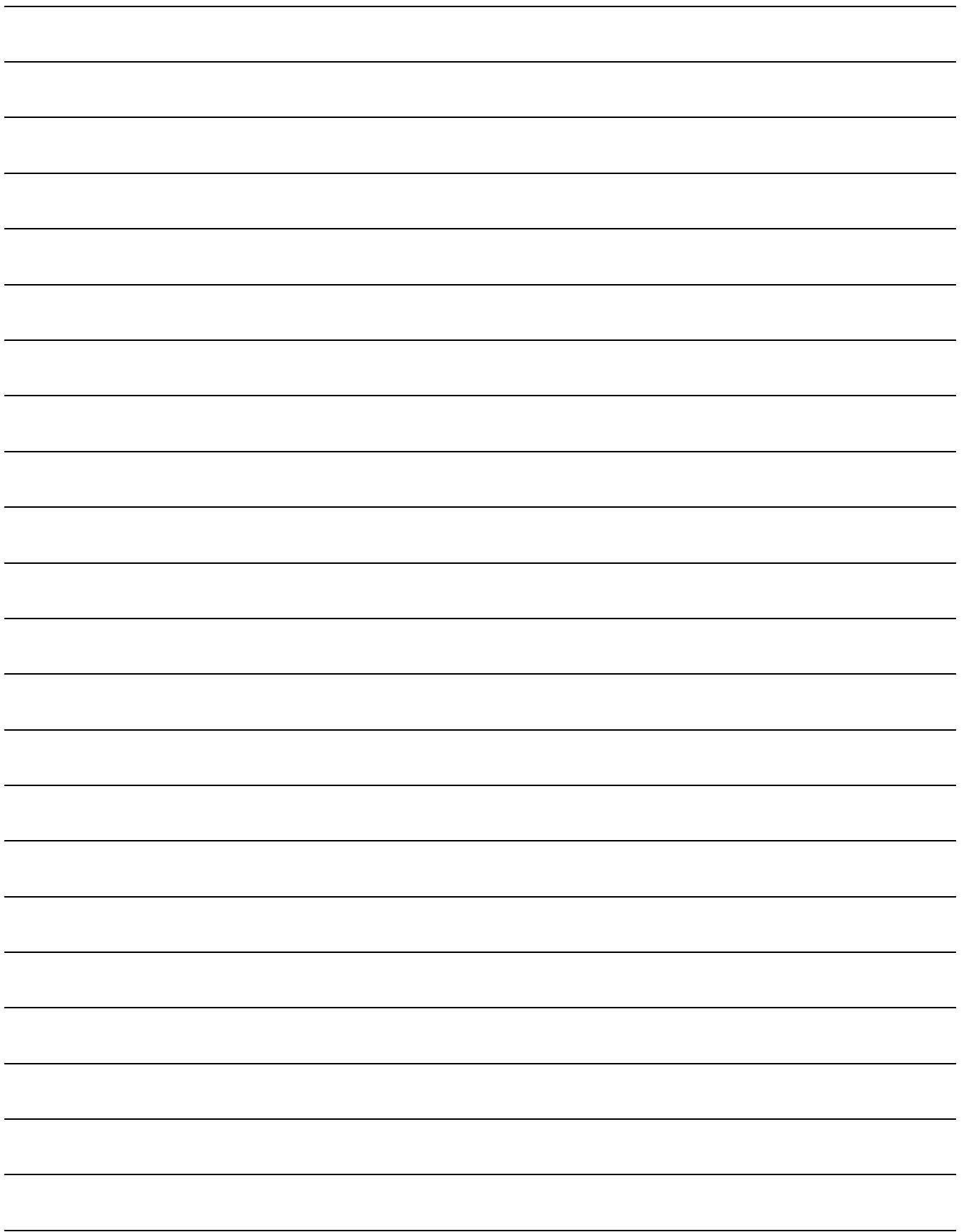



Germany

HEADQUARTERS

J. HELMKE & Co.

Ludwig-Erhard-Ring 7-9
31157 Sarstedt
Postfach 13 64
31153 Sarstedt
Tel.: +49 (0) 50 66 903 33-0
Fax: +49 (0) 50 66 903 33-291
E-Mail: helmke@helmke.de
www.helmke.de

HELMKE Orbis GmbH

Ludwig-Erhard-Ring 7-9
31157 Sarstedt
Postfach 12 03
31152 Sarstedt
Tel.: +49 (0) 50 66 903 33-0
Fax: +49 (0) 50 66 903 33-145
E-Mail: orbis@helmke.de
www.helmke.de

France

HELMKE S.à.r.l.

Z.I. -1 Allée Vert Bois
BP 17
68840 Pulversheim
Tel.: +33 (0) 389 83 25 25
Fax: +33 (0) 389 48 89 47
E-Mail: helmke@helmke.fr
www.helmke.fr

HELMKE S.à.r.l.

Bureau de Lyon
107, Cours Albert Thomas
69003 Lyon
Tel.: +33 (0) 4 72 12 06 39
Fax: +33 (0) 4 78 53 89 89
E-Mail: helmke.lyon@helmke.fr
www.helmke.fr

HELMKE Orbis S.à.r.l.

Z.I. -1 Allée Vert Bois
BP 17
68840 Pulversheim
Tel.: +33 (0) 3 89 83 25 25
Fax: +33 (0) 3 89 48 82 61
E-Mail: helmke.orbis@helmke.fr
www.helmke.fr

The Netherlands

HELMKE B.V.

Elektrische machines en aandrijvingen
Aalbosweg 24
8171 MA Vaassen
Postbus 195
8170 AD Vaassen
Tel.: +31 (0) 578 578 578
Fax: +31 (0) 578 578 585
E-Mail: info@helmke.nl
www.helmke.nl

Italy

HELMKE Italia S.r.l.

Via A. Volta, 18
20094 Corsico (Mi)
Tel.: +39 02 48 60 24 85
Fax: +39 02 48 60 24 94
E-Mail: info@helmke.it
www.helmke.it

Russia

J. HELMKE & Co.

Office Moscow
M.Malinovskogo 6k1, Office 3
RU-123298 Moscow
Tel.: +7 495 50 44 118
Fax: +7 499 50 44 122
E-Mail: info@helmke.ru
www.helmke.ru

Spain

HELMKE Orbis España

Camino de Mundaiz no. 10-2°
Ofic. 24-A
20012 San Sebastián
Tel.: +34 9 43 32 08 44
Fax: +34 9 43 32 13 09
E-Mail: info@helmke.es
www.helmke.es

Singapore

HELMKE Asia LLP

20 Maxwell Road
#04-02H Maxwell House
Singapore 069113
Tel.: +65 6534 7743
Fax: +65 6534 7743
E-Mail: info@helmke.sg
www.helmke.sg