



# HELMKE plus

Three-phase squirrel cage motors

low voltage

Frame size 63-355

DOR series

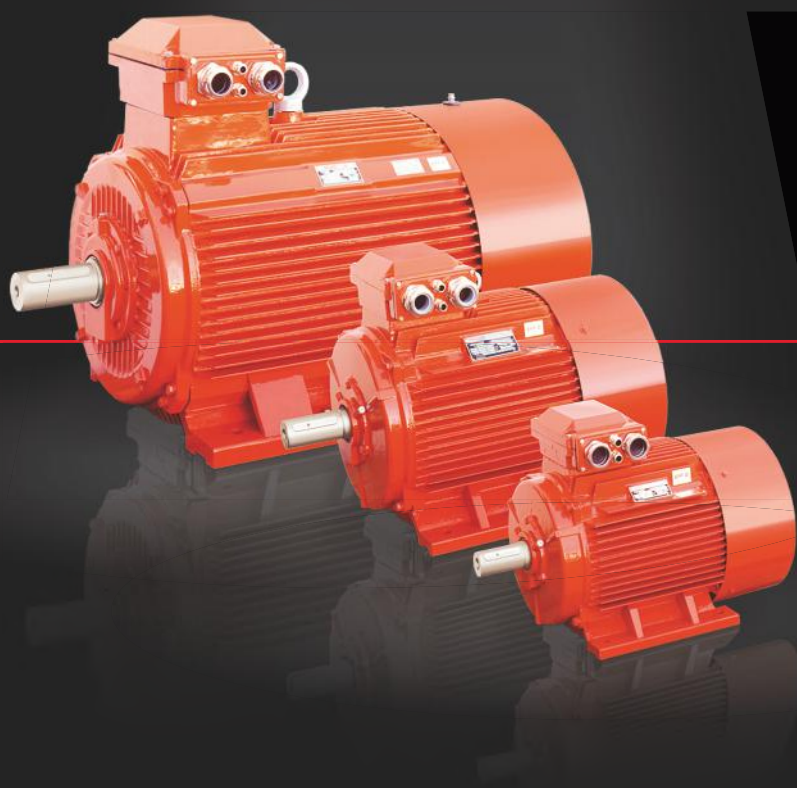

IE1 IE2 IE3



## Table of Contents

<b>General specification</b>	<b>4</b>
Standards and regulation .....	4
Conditions of installation .....	4
Painting .....	5
Insulation and temperature rise .....	5
Tolerances .....	6
Mechanical design .....	7
Mounting arrangements .....	8
Lubrication and maintenance of bearings.....	10
Lubricating nipples .....	10
Electrical design .....	11
Three-phase squirrel-cage motors driven by frequency inverters .....	15
<b>Aluminium Motors</b>	<b>17</b>
Overview aluminium motors .....	17
Terminal box .....	18
Materials.....	18
Bearings.....	18
Anti-condensation heating.....	21
Noise characteristics .....	21
Position and dimensions of the key.....	21
Technical data IE2 .....	22
Dimensions IE2 .....	26
Technical data IE3 .....	28
Dimensions IE3 .....	30
<b>Cast Iron Motors</b>	<b>33</b>
Overview cast iron motors.....	33
Terminal box .....	34
Materials.....	34
Bearings.....	35
Anti-condensation heating.....	38
Noise characteristics .....	38
Position and dimensions of the key.....	39
Technical Data IE2.....	40
Dimensions cast iron motors in frame size 63...180 IE2.....	48
Dimensions cast iron motors in frame size 200...355 IE2 .....	50
Technical Data IE3.....	54
Dimensions cast iron motors in frame size 63...180 IE3.....	60
Dimensions cast iron motors in frame size 200...355 IE3 .....	62
<b>Notes</b>	<b>65</b>

### Revisions

**All technical data, outputs, dimensions and weights, stated in this catalogue, are subject to change without notice. Illustrations do not purport to show constructional details.**

## General specification

### Standards and regulation

The motors comply with the relevant standards and regulations, especially:

#### Electrical

IEC-Standard	EN- Standard	Content
IEC 60034-1	EN 60034-1	Rating and performance
IEC 60034-8	EN 60034-8	Terminal markings and direction of rotation
IEC 60034-12	EN 60034-12	Starting performance
IEC 60034-30	EN 60034-30	Efficiency classes of single-speed, three-phase, cage-induction motors (IE-code)
IEC 60038	EN 60038	Standard voltages

#### Mechanical

IEC-Standard	EN- Standard	Content
IEC 60072	EN 50347	Dimensions and outputs
IEC 60034-5	EN 60034-5	Degrees of protection
IEC 60034-6	EN 60034-6	Methods of cooling
IEC 60034-7	EN 60034-7	Types of construction
IEC 60034-9	EN 60034-9	Noise limits
IEC 60034-14	EN 60034-14	Vibrations

### Conditions of installation

The motors are designed for operation at altitudes  $\leq 1000$  m above sea-level and at coolant temperature of up to 40 °C. Exceptions are indicated on the rating plate.

The motors comply with protection degree IP 55 according IEC 60034-5 (higher protection degrees on request).

Motors with standard design for horizontal mounting arrangements are suitable for indoor and protected outdoor installation, climate group MODERATE (temperature of coolant -20° C to +40° C).

In case of unprotected outdoor installation or aggravating climatic conditions (moisture category wet, climate group WORLDWIDE, extremely dusty site conditions, aggressive industrial atmosphere, danger of storm rain and coastal climate, danger of attack by termites, etc.), as well as vertical mounting, special measures are required, such as:

- Protective cowl (for vertical mounting with shaft-down)
- For vertical mounting with shaft-up flange drainage and additional bearing seal, if necessary
- Special painting
- Treatment of winding with moisture protection varnish
- Anti-condensation heating (anti-condensation heating of winding, if necessary)
- Condensation drain holes

The special measures to be applied have to be agreed with us once the conditions of installation have been clarified.



The respective conditions of installation have to be clearly indicated in the order.

## Painting

### Standard painting

Suitable for climate group Moderate according to DIN 600 721-2-1, e.g. indoor and outdoor installation

- short-term: up to 100 % humidity at temperatures up to +30°C
- long-term: up to 85 % humidity at temperatures up to +25°C

### Special painting K1

Suitable for climate group Worldwide according to DIN 600 721-2-1, e.g. outdoor installation in aggressive chemical atmosphere and coastal climate:

- short-term: up to 100 % humidity at temperatures up to +35°C
- long-term: up to 98 % humidity at temperatures up to +30°C

### Special designs (on request)

- Special painting K2 (additional treatment of internal motor parts)
- Special painting in case of alkalis
- Special painting according to customers' requirements

## Insulation and temperature rise

The insulation of the motors complies with temperature class F according to EN 60034-1.

The table beside defines the temperature rise ( $\Delta T^*$ ) and maximum temperatures at the hottest points of the winding ( $T_{\max}$ ) according to the temperature classes of the EN 60034-1 standard.

Class	$\Delta T^*$	$T_{\max}$
B	80 K	125° C
F	105 K	155° C
H	125 K	180° C



In case of coolant temperature of 40° C motors in standard design are only utilized according temperature class B – with an overtemperature limit of 80 K. This also applies for the rated voltage range according IEC 60038. Exceptions are shown on the selection tables.

### Derating at coolant temperatures over 40°C

Temperature of coolant	45° C	50° C	55° C	60° C
Reduction of nominal power to approx.	95 %	90 %	85 %	80 %

When a winding is utilized according to temperature class F (105 K), no derating is required up to a coolant temperature of 60 °C.



This does not apply to motors which are already utilized according to thermal class F in their standard design.

### Installation at altitudes of more than 1000 m above sea level (also see EN 60034-1)

In case of higher altitudes and coolant temperature of 40°C the nominal power has to be reduced approximately to the values defined in the table beside.

Temperature class	Altitude		
	2000 m	3000 m	4000 m
B	89 %	79 %	68 %
F	92 %	84 %	76 %

Installation at altitudes of more than 1000 m above sea level (also see EN 60034-1)

If the full nominal power according to the selection table is necessary, the temperature of the coolant is to be decreased according to the table beside.

Temperature class	Altitude		
	2000 m	3000 m	4000 m
B	30° C	19° C	9° C
F	32° C	24° C	16° C

### Tolerances

For industrial motors according to EN 60034-1, certain tolerances must be allowed on guaranteed values, taking into consideration the tolerances for the manufacture of such motors and the variances of the used materials. The standard specification sheet includes the following remarks:

- Guarantee of all or any of the values according to the table is not obligatory. Guaranteed values that are subject to tolerance have to be mentioned in offers explicit. The allowed tolerances must be in accordance with the table.
- Where a tolerance is stated in only one direction, the value is not limited in the other direction.

Values for	Tolerance
Efficiency ( $\eta$ ) (in case of indirect determination)	-0,15 x (1 - $\eta$ ) at $P_N \leq 50$ kW -0,1 x (1 - $\eta$ ) at $P_N > 50$ kW
Power factor ( $\cos \varphi$ )	$-\frac{1 - \cos \varphi}{6}$ , minimum 0.02, maximum 0.07
Slip (s) (at rated load and at working temperature)	$\pm 20$ % of the guaranteed slip at $P_N \geq 1$ kW $\pm 30$ % of the guaranteed slip at $P_N < 1$ kW
Starting current ( $I_s$ ) (in case of the intended starting circuit)	+20 % of the guaranteed starting current no lower limit
Starting torque ( $T_s$ )	-15 % and +25 % of the guaranteed starting torque (+25 % may be exceeded by agreement)
Pull-up torque ( $T_P$ )	-15 % of the guaranteed value
Breakdown torque ( $T_B$ )	-10 % of the guaranteed value (after allowing for this tolerance, $T_B / T_N$ at least 1,6)
Moment of inertia (I)	$\pm 10$ % of the guaranteed value

### Mechanical tolerances

According to IEC 72-1, the tolerances on mechanical dimensions of electric motors given beside are permitted.

Note: The holes at the shaft end correspond with DIN 332

Parameter	Code	Area	Tolerance
Frame size	H	up to 250 > 250	0.5 mm 1 mm
Diameter of shaft end	D-DA	from 11 to 28 mm from 38 to 48 mm from 55 to 100 mm	j6 k6 m6
Hub key width	F-FA		h9
Flange centring	N	up to 132 > 132	j6 h6

## Mechanical design

### Protection degrees

Protection degrees for electrical machines are designated in accordance with IEC 60034-5 by the letters IP and two characteristic numerals.

First numeral:  
Protection against contact and ingress of foreign bodies

Second numeral:  
Protection against ingress of water





IP	Description
0	No special protection
1	Protection against solid foreign bodies larger than 50 mm (Example: inadvertent contact with the hand)
2	Protection against solid foreign bodies larger than 12 mm (Example: inadvertent contact with the fingers)
3	Protection against solid foreign bodies larger than 2.5 mm (Example: Wires, tools)
4	Protection against solid foreign bodies larger than 1 mm (Example: Wires, bands)
5	Protection against dust (harmful deposits of dust)
6	Total protection against dust (is not described for electrical machines according IEC 34-5)

IP	Description
0	No special protection
1	Protection against vertically falling water drops (condensation)
2	Protection against dropping water when inclined by up to 15°
3	Protection against spray water up to 60° from vertical
4	Protection against shower water from any direction
5	Protection against water projected by a nozzle and from any direction
6	Protection against heavy seas or water projected in powerful jets
7	Protection when submerged between 0,15 and 1 m
8	Protection when continuously submerged in water at conditions agreed between the manufacturer and the user

## Mounting arrangements

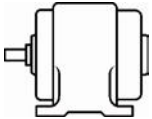
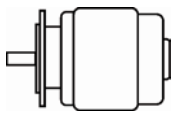
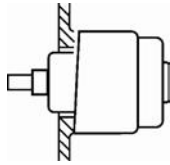
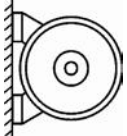
Mounting arrangements for rotating electrical machines are designated according to IEC 60034-7, Code I (in brackets Code II).

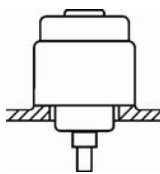
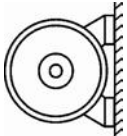
Our motors are available according to the table depending on design and frame size. Motors with aluminium frame are equipped with removable feet that allow easy change of mounting arrangement.

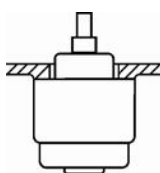
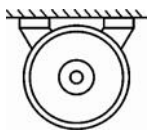
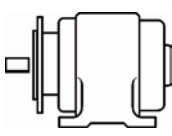
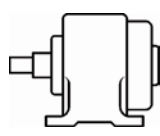
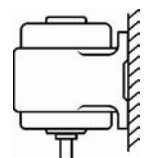
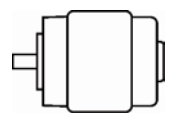
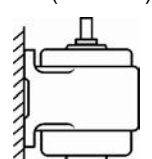
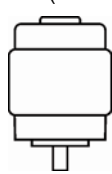
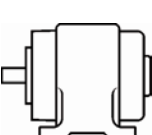
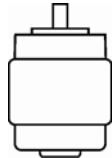
Foot mounting	Flange mounting	Motors without end shield
IM B3 (IM 1001) 	IM B5 (IM 3001)  Mounting flange type A according to DIN 42 948 at drive end	IM B9 (IM 9101)  Without end shield and without roller bearing on drive end
IM B6 (IM 1051) * 	IM V1 (IM 3011)  Mounting flange type A according to DIN 42 948 at drive end	IM V8 (IM 9111)  Without end shield and without roller bearing on drive end
IM B7 (IM 1061) * 	IM V3 (IM 3031)  Mounting flange type A according to DIN 42 948 at drive end	IM V9 (IM 9131)  Without end shield and without roller bearing on drive end
IM B8 (IM 1071) * 	IM B35 (IM 2001)  Mounting flange type A according to DIN 42 948 at drive end	IM B15 (IM 1201)  Without end shield and without roller bearing on drive end
IM V5 (IM 1011) * 	IM B14 (IM 3601)  Mounting flange type C according to DIN 42 948 at drive end	
IM V6 (IM 1031) * 	IM V18 (IM 3611)  Mounting flange type C according to DIN 42 948 at drive end	
IM B34 (IM 2101)  Mounting flange type C according to DIN 42 948 at drive end	IM V19 (IM 3631)  Mounting flange type C according to DIN 42 948 at drive end	

\* From frame size 225 on request

	<p>It is essential to state the desired mounting arrangement when ordering, as the constructive design depends partly on the mounting arrangement.</p>
---	--



### *Terminal boxes*

The location of the terminal box in standard design is on top (view to drive end); on the right or on the left is also possible. For motors with mounting arrangements IM B6, IM B7, IM B8, IM V5, IM V6 the location of the terminal box is related to an IM B3 mounting.

The position of the entry openings can be adapted to the existing connection possibilities for most motors by turning the terminal box by 90°. Please enquire if special accessories should be used (temperature sensors, anti-condensation heating, etc.).

For motors in standard design, the screwed stuffing boxes do not belong to our scope of delivery.

### *Belt drive*

The data refer only to the normal shaft end at the drive end of IM B3 motors with one speed.

Calculation of radial shaft load:

$$F_R = \frac{19120 \cdot P \cdot k}{D_1 \cdot n} [\text{N}]$$

$F_R$  = radial shaft load in N

$P$  = power in kW

$n$  = speed in  $\text{min}^{-1}$

$D_1$  = pulley diameter in m

$k$  = belt tension factor

The belt tension factor depends on the type of belt and is assumed to be approximately:

3...4 for normal flat belt without idle pulley

2...2,5 for normal flat belt with idle pulley

2,2...2,5 for V-belt

Please enquire exact data from the belt manufacturer.

### *Vibration behaviour*

The vibration severity of electric motors is determined in EN 60034-14 Mechanical vibration of certain machines with shaft heights 56 and higher - Measurement, evaluation and limits of vibration severity.

The rotors of the motors are dynamically balanced with half key fitted according to DIN ISO 8821. Other balancing is available by agreement only.

Our standard motors observe or fall below vibration category A. Motors with ball bearing can be supplied in vibration category B at extra cost.

### Maximum operating speed

Motors in basic design are mechanically suitable for the maximum operating speeds given beside.

Frame size	2-pole	4...8-pole
63...112	5200	3600
132...180	4600	3000
200	4500	3000
225	4500	3000
250	3900	3000
280	3600	3000
315 S/M	3600	2600
315 L	3600	2600
355 S	3600	2600
355 M	3600	2600
355 L	3600	2600

### Lubrication and maintenance of bearings

The bearings of standard motors up to frame size 160 (EH1) have permanent lubrication. Bearing grease K3N according DIN 51 825 is used (e.g. KLÜBER ASONIC GHY72, ESSO UNIREX N3 or similar).

Maintenance-free operating time of motors with permanent lubrication at ambient temperature of 40°C and 50 Hz mains operation:

- 2- and 4/2-pole motors 10,000 h
- 4 and more pole motors 20,000 h, but 4 years at most

From frame size 180 the motors are equipped with lubricator and grease.

First lubrication is made with grease K3N according DIN 51 825 (lithium-based, behaviour in the presence of water according DIN 51 807 part 1: level 0 or 1).

For motors with lubricator, the regreasing interval and required quantity of grease is indicated on the rating plate.

For regreasing please observe the operating instructions.

In case of unfavourable conditions (e.g. high ambient temperature, dusty conditions, corrosive atmosphere, operation by frequency inverter), regreasing should be carried out more frequently.

### Lubricating nipples

Flat type lubricating nipple M10x1 according DIN 3404.

## Electrical design

### Rated voltage

For the rated voltage of the motors a voltage tolerance of  $\pm 10\%$  applies. According to IEC 60038 the mains voltages may have a tolerance of  $\pm 10\%$ .

When the motors are operated at the limits of the voltage tolerance, the permissible overtemperature of the stator winding may be exceeded by 10 K.

### Rated frequency

Motors with windings for 50 Hz can be also operated on 60 Hz mains, when the mains voltage increases proportionally to the frequency. The relative values for starting and breakaway torque remain nearly unchanged and slightly increase for the starting current. The rated speed increases by the factor 1,2 and the rated power by factor 1,15. Should a motor designed for 50 Hz be operated at 60 Hz without the voltage being increased, the rated power of the motor cannot be increased. Under these operating conditions, the rated speed increases by factor 1,2. The relative values for starting and breakaway torque are reduced by factor 0,82 and the starting current by factor 0,9.

### Rated current

The rated currents listed in the selection tables apply to an operating voltage of 400 V. The conversion to other operating voltages, with power and frequency remaining unchanged, is to be made as follows:

Rated voltage (V)	230	380	400	440	500	660	690
Conversion factor $\times I_N$	1,74	1,05	1,0	0,91	0,80	0,61	0,58

### Rated torque

$$\text{Rated torque in Nm} = 9550 \cdot \frac{\text{Shaft power in kW}}{\text{Rated speed in rpm}}$$

### Power

The power stated in the table applies for constant load at continuous operation according duty class S1 of EN 60034-1, based on a coolant temperature of 40°C and installation at altitudes up to 1000 m above sea level.

For severe operating conditions, e.g. high switching rate, long run-up time or electric braking, a thermal reserve is necessary, which may require a higher temperature class or the use of a motor with higher rating. In these cases we recommend further enquiring and specification of the operating conditions.

### Overload capability

At operating temperature three-phase motors are capable of withstanding an overload for 2 minutes ( $\leq$  frame size 112: 15 seconds) with 1,5 times of the rated current at rated voltage. This overload capability complies with EN 60034-1 and will not result in excessive temperature rise.

When temperature class F is utilized, motors can be operated continuously with an overload of 12 %. This does not apply to motors which are already utilized according to thermal class F in their standard design.

## Connection diagrams

### Star connection

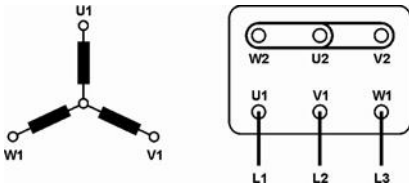

Star connection is obtained by connecting terminals W2, U2, V2 to each other and terminals U1, V1, W1 to the mains.

Phase current and phase voltage are:  $I_{ph} = I_N$ ;  $V_{ph} = V_N / \sqrt{3}$

$I_N$  is the rated current and  $V_N$  the rated voltage at star connection.

### Delta connection

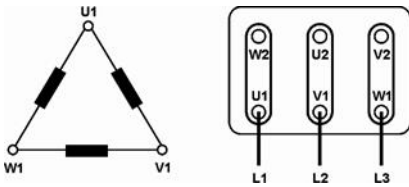

Delta connection is obtained by connecting the end of a phase to the beginning of the next phase.

Phase current and phase voltage are:  $I_{ph} = I_N / \sqrt{3}$ ;  $V_{ph} = V_N$

$I_N$  and  $V_N$  are rated current and rated voltage at delta connection.

### Star-delta connexion

Star-delta connection permits a reduction of the starting current, ensuring however that the resulting starting torque obtained is higher than the load torque. Thereby it should be observed that the torque of an asynchronous motor is directly proportional to the square of the voltage. Motors whose rated voltage with delta connection corresponds to the mains voltage, can be started with the star-delta method.

All motors can be supplied with windings designed for star-delta starting (for example: 400 V  $\Delta$  / 690 V Y).

### Starting rate

The number of starts per hour given in the table below is permitted without specific check, provided that the following conditions are met:

- Additional moment of inertia  $\leq$  moment of inertia of the rotor
- Load torque increases to nominal torque quadratic to the speed
- Starting in evenly intervals

Baugröße	Zulässige Anläufe / Stunde bei Polzahl		
	2	4	$\geq 6$
56...71	100	250	350
80...100	60	140	160
112...132	30	60	80
160...180	15	30	50
200...225	8	15	30
250...315	4	8	12

Please consult us and specify the complete operating conditions in order to ask for the permissible number of starts for motors of frame size 355.

*Motor protection*

The selection of the thermal motor protection should result from the existing operating conditions. Motors may be protected by means of current-dependent motor circuit breakers or overcurrent relays and temperature sensors.

*Motor protection is possible as follows:*

- Motor circuit breaker with bimetal switch
- Thermistor protection with thermistor temperature sensors (PTC) in the stator winding combined with relay (if required, with additional motor circuit breaker).
- Bimetal temperature sensor as N.C. or N.O. in the stator winding (if required, with additional motor circuit breaker).
- Resistance thermometer for monitoring of winding and bearing temperature.

If motor protection is necessary, motor circuit breakers with bimetal switches or thermistor temperature sensors (PTC) can be built in.

Although there are motors available from stock with built-in thermistor temperature sensor, a special remark has to be made in the enquiry or order when motor protection is required.

Functionality of bimetal temperature sensors

Ti Activation temperature

Tr Reset temperature

Type N/C (normally open)

Type N/C (normally closed)

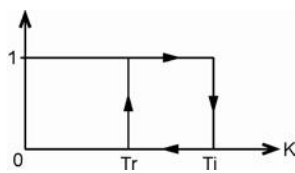
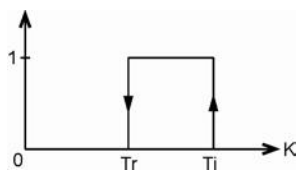

Functionality of thermistor temperature sensors (type PTC)

Ti Activation temperature

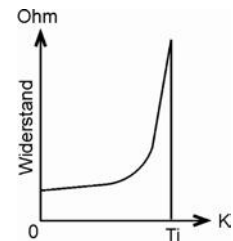

Connection examples

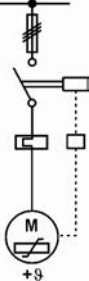
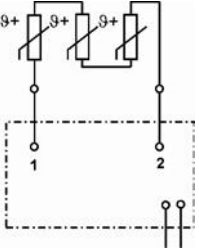
Protective measure	Protection against...
 <p data-bbox="371 387 866 448">Motor circuit breaker with thermal and electromagnetic overcurrent release</p>	<ul style="list-style-type: none"> <li>➤ Overload at continuous operation</li> <li>➤ Blocked rotor</li> </ul>
 <p data-bbox="371 768 718 842">Contactor with overcurrent relay Thermistor protection and fuse</p>	<p data-bbox="914 566 1190 600">during operation against :</p> <ul style="list-style-type: none"> <li>➤ Overload at continuous operation</li> <li>➤ Long starting and braking periods</li> <li>➤ High switching rate</li> </ul> <p data-bbox="914 790 1165 824">in case of fault against:</p> <ul style="list-style-type: none"> <li>➤ Obstruction of cooling</li> <li>➤ Increased temperature of coolant</li> <li>➤ Single-phase operation</li> <li>➤ Frequency variations</li> <li>➤ Blocked rotor</li> </ul>
 <p data-bbox="371 1294 842 1328">Thermistor temperature sensor with release</p>	<p data-bbox="914 1066 1190 1099">during operation against :</p> <ul style="list-style-type: none"> <li>➤ Overload at continuous operation</li> <li>➤ Long starting and braking periods</li> <li>➤ High switching rate</li> </ul> <p data-bbox="914 1290 1171 1323">in case of fault against :</p> <ul style="list-style-type: none"> <li>➤ Obstruction of cooling</li> <li>➤ Increased temperature of coolant</li> <li>➤ Single-phase operation</li> <li>➤ Frequency variations</li> <li>➤ Blocked rotor</li> </ul>

### Three-phase squirrel-cage motors driven by frequency inverters

The motors in standard design are suitable for operation on static frequency inverters, taking into account the following remarks:

- Maximum inverter output voltage 500 V at peak voltages  $\hat{U} \leq 1460$  V and  $dv/dt \leq 13$  kV/ms. For higher inverter output voltages or higher stress a special insulation is required.
- At square characteristic of the load torque, motors can be operated with their rated torque (exceptions are marked in the selection tables).
- In case of constant torque, the rated torque must be reduced for self-ventilated motors due to reduced supply of cooling air. Depending on the speed range, the use of an external fan is recommendable.
- Standard motors designed for 230V  $\Delta$  / 400V Y, 50 Hz can be operated with delta connection at 400 V and a base frequency of 87 Hz (observe the mechanical speed limits).
- For motors from frame size 280 we recommend an insulated bearing at the non-drive end.

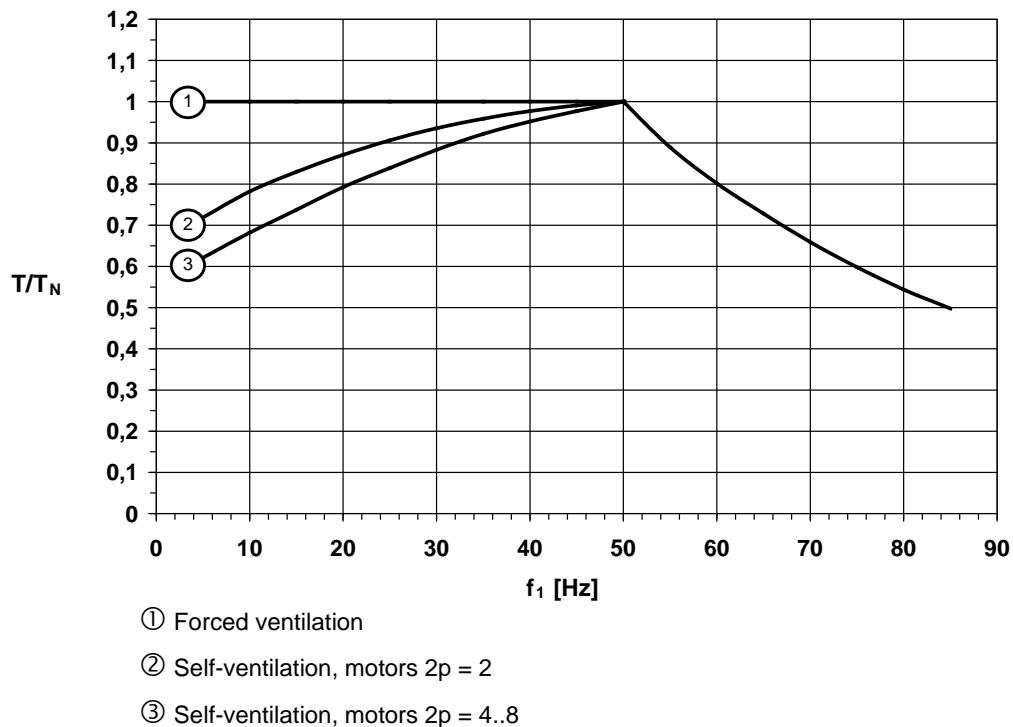

#### Voltage capability

The insulating system of the motors is suitable for inverter output voltages  $\leq 500$  V. Higher voltages are available on request.

#### Noises

Depending on the operating point, the type of inverter and the set pulse frequency, inverter-fed motors produce between 1 and 15 dB(A) higher noise values than at mains operation.

Motors that are operated with a frequency over 50 Hz have more air noise. In this case we recommend the use of an external fan.

#### Vibration severity

When operating at high speeds (according to frequency  $> 60$  Hz) a reduced vibration severity "B" according to EN 60034 part 14 may be required, measured at a mains frequency of 50 Hz or 60 Hz and sinusoidal mains voltage.





## Aluminium Motors

These asynchronous three-phase motors in a light metal design with a low motor weight and simple to adjustable terminal box position are available in various designs.

This motor range is deliverable ex stock for the whole power range

### Overview aluminium motors

Type	Frame size	Rated power [kW]			
		2-pole	4-pole	6-pole	8-pole
DOR63M1	63	0,18	0,12	–	–
DOR63M2	63	0,25	0,18	–	–
DOR71M1	71	0,37	0,25	0,18	–
DOR71M2	71	0,55	0,37	0,25	–
DOR80M1	80	0,75	0,55	0,37	0,18
DOR80M2	80	1,1	0,75	0,55	0,25
DOR90S	90S	1,5	1,1	0,75	0,37
DOR90L	90L	2,2	1,5	1,1	0,55
DOR100L, L1	100L	3,0	2,2	1,5	0,75
DOR100L2	100L	–	3,0	–	1,1
DOR112M	112M	4,0	4,0	2,2	1,5
DOR132S1	132S	5,5	–	–	–
DOR132S, S2	132S	7,5	5,5	3,0	2,2
DOR132M1	132M	–	–	4,0	–
DOR132M, M2	132M	–	7,5	5,5	3,0
DOR160M1	160M	11	–	–	4,0
DOR160M, M2	160M	15	11	7,5	5,5
DOR160L	160L	18,5	15	11	7,5

#### General data

- Voltage/Connection  
up to 2,2 kW: 230 V Δ / 400 V Y  
from 3,0 kW: 400 V Δ / 690 V Y
  
- Mounting arrangements  
IM 1001 (B3), IM 3001 (B5), IM 3601 (B14)  
feet can be mounted on flange-mounted motors
  
- Thermistor  
3 PTC built-in standard-like

## Terminal box

Frame size	Degree of protection	Hole for cable entry	Connection for temperature sensor	Max. conductor cross section [mm <sup>2</sup> ]	Connecting bolt	Max. external cable diameter [mm]
		Metric	Metric			
63	IP 55	1 x M20x1,5	1 x M20x1,5	2,5	M4	13
71	IP 55	1 x M20x1,5	1 x M20x1,5	2,5	M4	13
80	IP 55	1 x M20x1,5	1 x M20x1,5	2,5	M4	13
90	IP 55	1 x M20x1,5	1 x M20x1,5	2,5	M4	13
100	IP 55	1 x M20x1,5	1 x M20x1,5	2,5	M4	13
112	IP 55	2 x M32x1,5	1 x M20x1,5	4	M4	21
132	IP 55	2 x M32x1,5	1 x M20x1,5	4	M4	21
160	IP 55	2 x M40x1,5	1 x M25x1,5	16	M5	27

## Materials

Designation	Frame size	Material
Stator frame	63...160	Aluminium alloy
End shield	63...160	Aluminium alloy from frame size 90 with steel bush at drive end (seat of the bearing)
Flanged endshield	63...160	Aluminium alloy from frame size 90 with steel bush at drive end (seat of the bearing)
Fan cover	63...160	Sheet steel
Fan	63...160	Plastic material
Terminal box	63...160	Aluminium alloy

## Bearings

Allocation of bearings (standard design)

Ball bearings according to ISO 15 (DIN 625)

Frame size	No. of poles	Drive end	Non-drive end
63	2...8	6201-2Z C3	6201-2Z C3
71	2...8	6202-2Z C3	6202-2Z C3
80	2...8	6204-2Z C3	6204-2Z C3
90	2...8	6205-2Z C3	6205-2Z C3
100	2...8	6206-2Z C3	6206-2Z C3
112	2...8	6306-2Z C3	6306-2Z C3
132	2...8	6308-2Z C3	6308-2Z C3
160	2...8	6309-2Z C3	6309-2RS C3 ( <b>IE2</b> ) 6209-2RS C3 ( <b>IE3</b> )

Standard design of bearings

(other designs on request)

Frame size	Bearing drive end	Bearing non-drive end	Spring-loaded
63...160	Located bearing	Non-located bearing	Non-drive end

*Maximum permissible axial loads without additional radial load*

Values are valid for 50 Hz. For 60 Hz operation the values have to be reduced by 10%. (if additional radial forces affect, enquiry is necessary depending on the direction of force)

*Horizontal shaft*

Frame size	Axial load [kN]			
	3000 min <sup>-1</sup>	1500 min <sup>-1</sup>	1000 min <sup>-1</sup>	750 min <sup>-1</sup>
63	0,25	0,28	–	–
71	0,27	0,35	0,44	–
80	0,38	0,47	0,59	0,62
90	0,44	0,55	0,62	0,64
100	0,61	0,75	0,88	0,89
112	1,22	1,44	1,65	1,78
132	1,50	1,78	1,82	1,92
160	1,65	2,10	2,45	2,65

*Vertical shaft downwards*

Frame size	Axial load upwards [kN]				Axial load downwards [kN]			
	3000 min <sup>-1</sup>	1500 min <sup>-1</sup>	1000 min <sup>-1</sup>	750 min <sup>-1</sup>	3000 min <sup>-1</sup>	1500 min <sup>-1</sup>	1000 min <sup>-1</sup>	750 min <sup>-1</sup>
63	0,26	0,3	–	–	0,23	0,26	–	–
71	0,29	0,37	0,46	–	0,25	0,32	0,42	–
80	0,40	0,49	0,62	0,65	0,36	0,45	0,56	0,59
90	0,47	0,60	0,68	0,70	0,41	0,51	0,46	0,58
100	0,67	0,84	0,97	0,97	0,57	0,71	0,82	0,84
112	1,30	1,52	1,74	1,88	1,17	1,37	1,58	1,71
132	1,62	1,97	2,00	2,10	1,43	1,61	1,66	1,76
160	1,95	2,47	2,80	3,05	1,35	1,72	2,05	2,21

Permissible radial loads

without additional axial load (ball bearing)

max. permissible radial loads in the table are valid for  
 $X = 1/2$  shaft length

Frame size	F <sub>R</sub> in N for number of poles			
	2	4	6	8
63	300	300	–	–
71	400	400	400	–
80	610	650	750	820
90S/L	660	710	810	890
100L	920	990	1130	1240
112M	1330	1430	1640	1800

Nominal life cycle = 20,000 h (Lh 10)

F<sub>R</sub> = permissible radial load in kN (without additional axial load)

X = Distance between working point of force and shaft shoulder (e.g. half pulley width)

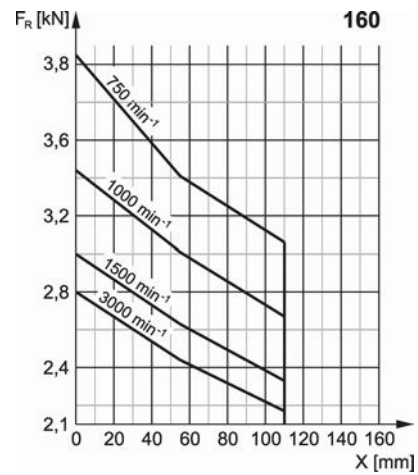
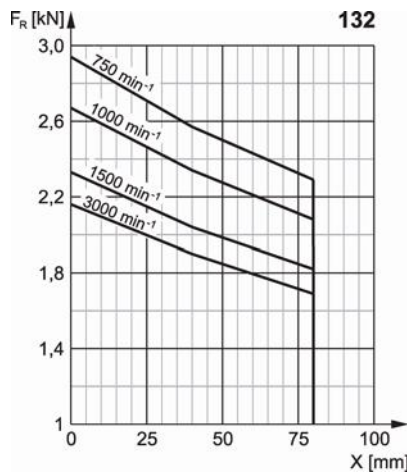

A modification of the normal design to cylindrical roller bearings is not possible.

For calculation of the radial forces see *Belt drive* on page 9.

### Anti-condensation heating

Motors which are exposed to a risk of humidity during standstill due to severe temperature variations can be equipped with anti-condensation heating (strip heaters) for an extra charge, if requested.

The supply voltage and the heating power of the strip heaters can be taken from the table beside.

Frame size	Supply voltage [V]	Heizleistung/Motor [W]
132...160	230	2x40



During operation of the motor, the anti-condensation heating must be switched off.

### Noise characteristics

The noise values listed beside are valid for 50 Hz at rated voltage with a tolerance of up to +3 dB(A).

3...5 dB(A) higher values are the recommended values for operation at 60 Hz.

Frame size	Sound pressure level $L_{pa}$ [dB(A)]			
	2-pole	4-pole	6-pole	8-pole
71	53	44	40	37
80	56	47	41	40
90	60	49	45	41
100	64	53	49	44
112	65	54	53	48
132	68	62	63	50
160	74	66	66	54

### Position and dimensions of the key

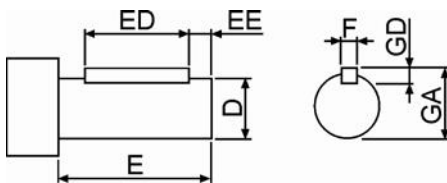

Frame size	Dimensions [mm]				
	D X E	F X GD	ED	EE	GA
71	14 X 30	5 X 5	25	2,5	16
80	19 X 40	6 X 6	30	5	21,5
90	24 X 50	8 X 7	40	5	27
100	28 X 60	8 X 7	50	5	31
112	28 X 60	8 X 7	50	5	31
132	38 X 80	10 X 8	65	7,5	41
160	42 X 110	12 X 8	90	10	45



For longer shafts in special design the dimensions ED and EE are kept.

## Technical data IE2

Type	Frame size	Ratings for mains operation										For direct-on-line starting		
		Rated power	Rated speed	Rated torque	Efficiency class acc. to EN 60034-30	Efficiency EN60034-2-1 : 2007			Power factor	Rated current at		Starting current	Starting torque	Break-down torque
		$P_N$ [kW]	$n_N$ [min <sup>-1</sup> ]	$T_N$ [Nm]		$\eta$ [%]				$\cos \varphi$	$I_N$ [A]			
					100%	75%	50%		400V	380... 420V	$I_s/I_N$	$T_s/T_N$	$T_B/T_N$	

Helmke DOR – aluminium Motors

**IE2**

### 3000 min-1 (2-pole)

DOR63M1-02-1A	63	0,18	2710	0,63		63,0	62,8	59,2	0,75	0,54	0,57	6,0	2,2	2,4
DOR63M2-02-1A	63	0,25	2710	0,88		65,0	64,8	61,2	0,78	0,71	0,74	6,0	2,2	2,4
DOR71M1-02-1A	71	0,37	2730	1,29		70,0	69,8	66,5	0,79	0,96	1,01	6,0	2,2	2,4
DOR71M2-02-1A	71	0,55	2740	1,91		71,0	70,8	67,6	0,79	1,41	1,48	6,0	2,2	2,4
DOR80M1-02-2A	80	0,75	2875	2,49	<b>IE2</b>	77,4	77,2	74,5	0,83	1,68	1,76	5,8	2,9	3,3
DOR80M2-02-2A	80	1,1	2870	3,66	<b>IE2</b>	79,6	79,4	76,9	0,83	2,4	2,52	6,8	3,5	3,6
DOR90S-02-2A	90	1,5	2885	4,9	<b>IE2</b>	81,3	81,1	78,7	0,84	3,17	3,32	6,9	3,5	3,6
DOR90L-02-2A	90	2,2	2875	7,3	<b>IE2</b>	83,2	83,1	80,8	0,85	4,4	4,7	7,9	4,1	4,1
DOR100L-02-2A	100	3	2880	9,9	<b>IE2</b>	84,6	84,5	82,4	0,87	5,8	6,1	7,8	3,4	3,4
DOR112M-02-2A	112	4	2900	13,1	<b>IE2</b>	85,8	85,7	83,7	0,88	7,6	8,0	7,5	2,7	3,3
DOR132S1-02-2A	132	5,5	2920	17,9	<b>IE2</b>	87,0	86,9	85,1	0,86	10,6	11,1	7,7	2,4	3,0
DOR132S2-02-2A	132	7,5	2915	24,5	<b>IE2</b>	88,1	88,0	86,3	0,88	13,9	14,6	8,4	2,6	3,2
DOR160M1-02-2A	160	11	2930	35,8	<b>IE2</b>	89,4	89,3	87,8	0,89	19,9	20,9	7,6	2,4	3,1
DOR160M2-02-2A	160	15	2930	48,8	<b>IE2</b>	90,3	90,2	88,8	0,89	26,9	28,2	8,0	2,6	3,2
DOR160L-02-2A	160	18,5	2935	60,1	<b>IE2</b>	90,9	90,8	89,5	0,89	33	34,6	9,0	3,0	3,5

### 1500 min-1 (4- pole)

DOR63M1-04-1A	63	0,12	1330	0,86		57,0	56,8	53,0	0,64	0,47	0,49	4,0	2,2	2,4
DOR63M2-04-1A	63	0,18	1330	1,29		59,0	58,8	55,1	0,65	0,67	0,71	6,0	2,2	2,4
DOR71M1-04-1A	71	0,25	1330	1,79		60,0	59,8	56,1	0,72	0,83	0,87	6,0	2,2	2,4
DOR71M2-04-1A	71	0,37	1330	2,65		65,0	64,8	61,2	0,74	1,11	1,16	6,0	2,2	2,4
DOR80M1-04-1A	80	0,55	1370	3,83		67,0	66,8	63,3	0,75	1,57	1,65	6,0	2,2	2,4
DOR80M2-04-2A	80	0,75	1400	5,1	<b>IE2</b>	79,6	79,4	76,9	0,75	1,81	1,9	5,3	2,8	3,0
DOR90S-04-2A	90	1,1	1440	7,2	<b>IE2</b>	81,4	81,2	78,8	0,77	2,53	2,65	6,7	3,8	2,6
DOR90L-04-2A	90	1,5	1440	9,9	<b>IE2</b>	82,8	82,7	80,4	0,77	3,39	3,56	7,2	4,0	2,7
DOR100L1-04-2A	100	2,2	1440	14,5	<b>IE2</b>	84,3	84,2	82,0	0,81	4,6	4,8	7,4	3,6	3,6
DOR100L2-04-2A	100	3	1440	19,8	<b>IE2</b>	85,5	85,4	83,4	0,82	6,1	6,4	7,8	3,8	3,5
DOR112M-04-2A	112	4	1445	26,4	<b>IE2</b>	86,6	86,5	84,6	0,82	8,1	8,5	7,1	3,1	2,9
DOR132S-04-2A	132	5,5	1455	36	<b>IE2</b>	87,7	87,6	85,9	0,83	10,9	11,4	7,4	2,6	2,7
DOR132M-04-2A	132	7,5	1455	49,2	<b>IE2</b>	88,7	88,6	87,0	0,84	14,5	15,2	7,7	2,8	2,7
DOR160M-04-2A	160	11	1460	71,9	<b>IE2</b>	89,8	89,7	88,2	0,84	21,0	22,1	7,7	2,7	3,1
DOR160L-04-2A	160	15	1460	98,1	<b>IE2</b>	90,6	90,5	89,1	0,85	28,1	29,5	7,3	2,4	2,6

Type	Ratings for operation with IGBT converter									Inertia J [10 <sup>-3</sup> kgm <sup>2</sup> ]	Weight [kg]
	T ~ n <sup>2</sup> , self-ventilated or T = constant, forced-ventilated			T = constant, self-ventilated			T = constant, self-ventilated				
	Speed range 5...50 Hz			Speed range 17...50 Hz			Speed range 5...50 Hz				
P at 50 Hz [kW]	I [A]	Temp. class	P at 50 Hz [kW]	T [Nm]	I [A]	P at 50 Hz [kW]	T [Nm]	I [A]	J	Weight	

Helmke DOR – aluminium motors

**IE2**

3000 min<sup>-1</sup> (2-pole)

DOR63M1-02-1A	0,18	0,57	F	0,15	0,52	0,48	0,12	0,42	0,41	0,14	4
DOR63M2-02-1A	0,25	0,74	F	0,21	0,74	0,62	0,18	0,63	0,53	0,16	4,2
DOR71M1-02-1A	0,37	1,01	F	0,31	1,08	0,85	0,26	0,9	0,72	0,34	5,2
DOR71M2-02-1A	0,55	1,48	F	0,46	1,6	1,25	0,39	1,35	1,06	0,42	6
DOR80M1-02-2A	0,75	1,76	F	0,63	2,09	1,49	0,54	1,79	1,26	0,78	8,7
DOR80M2-02-2A	1,1	2,52	F	0,93	3,09	2,14	0,79	2,62	1,81	0,98	10
DOR90S-02-2A	1,5	3,32	F	1,27	4,2	2,82	1,08	3,57	2,39	1,5	13
DOR90L-02-2A	2,2	4,7	F	1,87	6,2	3,99	1,58	5,2	3,38	1,6	15
DOR100L-02-2A	3	6,1	F	2,55	8,4	5,1	2,16	7,1	4,3	3,2	24
DOR112M-02-2A	4	8	F	3,4	11,1	6,8	2,88	9,4	5,7	4,9	25
DOR132S1-02-2A	5,5	11,1	F	4,6	15,0	9,4	3,96	12,9	7,9	11,6	43
DOR132S2-02-2A	7,5	14,6	F	6,3	20,6	12,4	5,4	17,6	10,5	14,3	48
DOR160M1-02-2A	11	20,9	F	9,3	30,3	17,7	7,9	25,7	15,0	47	77
DOR160M2-02-2A	15	28,2	F	12,7	41,3	23,9	10,8	35,2	20,3	57,2	92
DOR160L-02-2A	18,5	34,6	F	15,7	51,0	29,4	13,3	43,2	24,9	66	104

1500 min<sup>-1</sup> (4- pole)

DOR63M1-04-1A	0,12	0,49	F	0,09	0,64	0,37	0,07	0,5	0,3	0,28	3,7
DOR63M2-04-1A	0,18	0,71	F	0,13	0,93	0,53	0,11	0,78	0,44	0,32	4,2
DOR71M1-04-1A	0,25	0,87	F	0,19	1,36	0,66	0,15	1,07	0,54	0,51	5
DOR71M2-04-1A	0,37	1,16	F	0,28	2,01	0,88	0,23	1,65	0,72	8,1	5,8
DOR80M1-04-1A	0,55	1,65	F	0,41	2,85	1,25	0,34	2,37	1,03	1,2	8,1
DOR80M2-04-2A	0,75	1,9	F	0,57	3,88	1,44	0,46	3,13	1,18	1,9	10
DOR90S-04-2A	1,1	2,65	F	0,83	5,5	2,01	0,68	4,5	1,65	2,4	14
DOR90L-04-2A	1,5	3,56	F	1,14	7,5	2,7	0,93	6,1	2,22	3,1	17
DOR100L1-04-2A	2,2	4,8	F	1,67	11,0	3,64	1,37	9,0	3,0	6	20
DOR100L2-04-2A	3	6,4	F	2,28	15,1	4,8	1,87	12,4	4,0	7,3	21
DOR112M-04-2A	4	8,5	F	3,04	20	6,4	2,5	16,5	5,3	11,1	30
DOR132S-04-2A	5,5	11,4	F	4,1	26,9	8,6	3,43	22,5	7,1	23,6	43
DOR132M-04-2A	7,5	15,2	F	5,7	37,4	11,5	4,6	30,1	9,5	29,9	52
DOR160M-04-2A	11	22,1	F	8,3	54,2	16,7	6,8	44,4	13,8	84,5	83
DOR160L-04-2A	15	29,5	F	11,4	74,5	22,4	9,3	60,8	18,4	110	102

Type	Frame size	Ratings for mains operation										For direct-on-line starting		
		Rated power	Rated speed	Rated torque	Efficiency class acc. to EN 60034-30	Efficiency EN60034-2-1 : 2007			Power factor	Rated current at		Starting current	Starting torque	Break-down torque
		P <sub>N</sub> [kW]	n <sub>N</sub> [min <sup>-1</sup> ]	T <sub>N</sub> [Nm]		η [%]				cos φ	I <sub>N</sub> [A]			
					100%	75%	50%		400V	380... 420V	I <sub>s</sub> /I <sub>N</sub>	T <sub>s</sub> /T <sub>N</sub>	T <sub>B</sub> /T <sub>N</sub>	

Helmke DOR – aluminium Motors

**IE2**

1000 min<sup>-1</sup> (6-pole)

DOR71M1-06-1A	71	0,18	850	2,02		56,0	55,8	52,0	0,66	0,7	0,73	4,0	1,6	1,7
DOR71M2-06-1A	71	0,25	850	2,8		59,0	58,8	55,1	0,68	0,89	0,94	4,0	2,1	2,2
DOR80M1-06-1A	80	0,37	885	3,99		62,0	61,8	58,1	0,70	1,23	1,29	4,0	1,9	1,9
DOR80M2-06-1A	80	0,55	885	5,9		65,0	64,8	61,2	0,72	1,69	1,78	4,0	2,0	2,3
DOR90S-06-2A	90	0,75	935	7,6	<b>IE2</b>	75,9	75,7	72,8	0,72	1,98	2,07	4,7	3,1	3,1
DOR90L-06-2A	90	1,1	945	11,1	<b>IE2</b>	78,1	77,9	75,2	0,72	2,82	2,96	5,0	3,2	3,2
DOR100L-06-2A	100	1,5	945	15,1	<b>IE2</b>	79,8	79,6	77,1	0,75	3,61	3,79	5,9	3,1	2,9
DOR112M-06-2A	112	2,2	960	21,8	<b>IE2</b>	81,8	81,7	79,3	0,76	5,1	5,3	5,5	2,6	2,8
DOR132S-06-2A	132	3	965	29,6	<b>IE2</b>	83,3	83,2	80,9	0,76	6,8	7,1	5,7	2,2	2,7
DOR132M1-06-2A	132	4	965	39,5	<b>IE2</b>	84,6	84,5	82,4	0,76	8,9	9,4	6,2	2,4	2,7
DOR132M2-06-2A	132	5,5	965	54,4	<b>IE2</b>	86,0	85,9	83,9	0,77	11,9	12,5	6,7	2,6	2,7
DOR160M-06-2A	160	7,5	970	73,8	<b>IE2</b>	87,2	87,1	85,3	0,78	15,9	16,7	5,6	2,0	2,8
DOR160L-06-2A	160	11	970	108	<b>IE2</b>	88,7	88,6	87,0	0,78	22,9	24,0	5,8	2,0	2,8

750 min<sup>-1</sup> (8- pole)

DOR80M1-08-1A	80	0,18	645	2,66		50,3	50,0	46,2	0,61	0,84	0,88	2,8	1,5	1,7
DOR80M2-08-1A	80	0,25	645	3,7		54,0	53,8	50,0	0,61	1,09	1,15	2,7	1,6	2,0
DOR90S-08-1A	90	0,37	670	5,2		62,0	61,8	58,1	0,61	1,41	1,48	2,8	1,6	1,8
DOR90L-08-1A	90	0,55	670	7,8		63,0	62,7	59,1	0,61	2,06	2,17	3,0	1,6	1,8
DOR100L1-08-1A	100	0,75	680	10,5		66,0	65,8	62,3	0,67	2,44	2,57	3,5	1,7	2,1
DOR100L2-08-1A	100	1,1	680	15,4		72,0	71,8	68,6	0,69	3,19	3,35	3,5	1,7	2,1
DOR112M-08-1A	112	1,5	690	20,7		74,0	73,8	70,8	0,68	4,3	4,5	4,2	1,8	2,1
DOR132S-08-1A	132	2,2	705	29,8		75,0	74,8	71,9	0,71	5,9	6,2	5,5	2,0	2,0
DOR132M-08-1A	132	3	705	40,6		77,0	76,8	74,0	0,73	7,7	8,0	5,5	2,0	2,0
DOR160M1-08-1A	160	4	720	53		80,0	79,8	77,3	0,73	9,8	10,3	6,0	1,9	2,1
DOR160M2-08-1A	160	5,5	720	72,9		83,1	82,9	80,7	0,74	12,9	13,5	6,0	2,0	2,2
DOR160L-08-1A	160	7,5	720	99,4		85,0	84,9	82,8	0,75	16,9	17,8	6,0	1,9	2,2



Type	Ratings for operation with IGBT converter									Inertia J [10 <sup>-3</sup> kgm <sup>2</sup> ]	Weight [kg]
	T ~ n <sup>2</sup> , self-ventilated or T = constant, forced-ventilated			T = constant, self-ventilated			T = constant, self-ventilated				
	Speed range 5...50 Hz			Speed range 17...50 Hz			Speed range 5...50 Hz				
P at 50 Hz [kW]	I [A]	Temp. class	P at 50 Hz [kW]	T [Nm]	I [A]	P at 50 Hz [kW]	T [Nm]	I [A]	J	Weight	

Helmke DOR – aluminium motors

**IE2**

1000 min<sup>-1</sup> (6-pole)

DOR71M1-06-1A	0,18	0,73	F	0,13	1,46	0,55	0,11	1,23	0,45	0,83	5,6
DOR71M2-06-1A	0,25	0,94	F	0,19	2,13	0,71	0,15	1,68	0,58	0,95	6
DOR80M1-06-1A	0,37	1,29	F	0,28	3,02	0,98	0,23	2,48	0,8	1,5	9,6
DOR80M2-06-1A	0,55	1,78	F	0,41	4,4	1,35	0,34	3,66	1,11	2,3	10
DOR90S-06-2A	0,75	2,07	F	0,57	5,8	1,57	0,46	4,6	1,29	2,5	12
DOR90L-06-2A	1,1	2,96	F	0,83	8,3	2,24	0,68	6,8	1,85	3,5	16
DOR100L-06-2A	1,5	3,79	F	1,14	11,5	2,88	0,93	9,3	2,36	7,8	21
DOR112M-06-2A	2,2	5,3	F	1,67	16,6	4,0	1,37	13,6	3,31	14,7	29
DOR132S-06-2A	3	7,1	F	2,28	22,5	5,3	1,87	18,5	4,4	27,6	35
DOR132M1-06-2A	4	9,4	F	3,04	30	7,1	2,5	24,7	5,8	36,5	49
DOR132M2-06-2A	5,5	12,5	F	4,1	40,5	9,5	3,43	33,9	7,8	47,8	54
DOR160M-06-2A	7,5	16,7	F	5,7	56,1	12,6	4,6	45,2	10,4	90,8	72
DOR160L-06-2A	11	24	F	8,3	81,7	18,2	6,8	66,9	15	118	87

750 min<sup>-1</sup> (8- pole)

DOR80M1-08-1A	0,18	0,88	F	0,13	1,92	0,66	0,11	1,62	0,55	2	9,4
DOR80M2-08-1A	0,25	1,15	F	0,19	2,81	0,87	0,15	2,22	0,71	2,5	10
DOR90S-08-1A	0,37	1,48	F	0,28	3,99	1,12	0,23	3,27	0,92	3,7	12
DOR90L-08-1A	0,55	2,17	F	0,41	5,8	1,64	0,34	4,8	1,35	4,6	15
DOR100L1-08-1A	0,75	2,57	F	0,57	8,0	1,95	0,46	6,4	1,6	6,1	17
DOR100L2-08-1A	1,1	3,35	F	0,83	11,6	2,54	0,68	9,5	2,09	7,5	19
DOR112M-08-1A	1,5	4,5	F	1,14	15,7	3,42	0,93	12,8	2,81	12,9	25
DOR132S-08-1A	2,2	6,2	F	1,67	22,6	4,7	1,37	18,5	3,87	29,8	34
DOR132M-08-1A	3	8	F	2,28	30,8	6,0	1,87	25,3	5	38,7	40
DOR160M1-08-1A	4	10,3	F	3,04	40,3	7,8	2,5	33,1	6,4	53,7	59
DOR160M2-08-1A	5,5	13,5	F	4,1	54,3	10,2	3,43	45,4	8,4	77,2	69
DOR160L-08-1A	7,5	17,8	F	5,7	75,6	13,5	4,6	61,0	11,1	109	87

## Dimensions IE2

Mounting arrangement IM 1001 (B3)

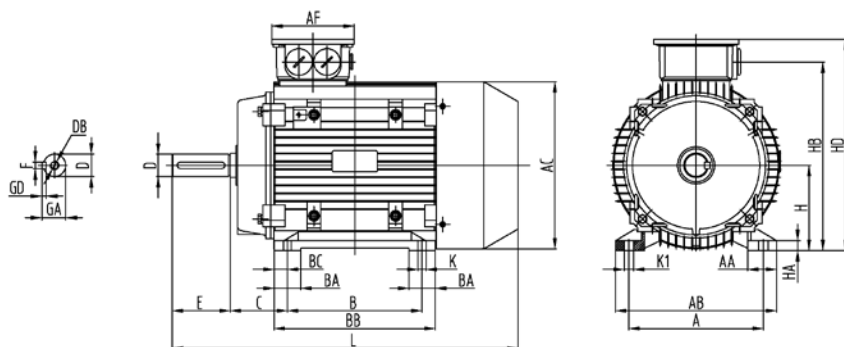

Type	Frame size	No. of poles	Dimensions according to IEC [mm]													
			H	A	B	C	AB	BB	BC	HD	AC	HB	HA	K	K1	L
			Dimensions according to DIN [mm]													
<b>IE2</b>			h	b	a	w1	f	e		m1	g	v	c	s		k
DOR63M1, M2	63	2...4	63	100	80	40	120	103	11,5	171	130	145	7	7	10	220
DOR71M1, M2	71	2...4	71	112	90	45	132	105	7,5	186	147	160	10	7	10	241
DOR80M1, M2	80	2...6	80	125	100	50	160	130	15	213	163	187	10	10	13	290
DOR90S	90S	2...8	90	140	100	56	175	130	15	229	183	203	12	10	13	312
DOR90L	90L	2...8	90	140	125	56	175	155	15	229	183	203	12	10	13	337
DOR100L, L1, L2	100L	2...8	100	160	140	63	198	176	18	252	205	226	14	12	16	369
DOR112M	112M	2...8	112	190	140	70	220	180	20	279	229	248	17	12	16	395
DOR132S, S1, S2	132S	2...8	132	216	140	89	252	176	18	318	265	287	16	12	16	437
DOR132M, M1, M2	132M	2...8	132	216	178	89	252	214	18	318	265	287	16	12	16	475
DOR160M, M1, M2	160M	2...8	160	254	210	108	290	294	20	384	325	349	16	15	19	640
DOR160L	160L	2...8	160	254	254	108	290	394	20	384	325	349	16	15	19	640

Type	Frame size	No. of poles	Dimensions according to IEC [mm]							
			AF	AA	D	E	F	GD	GA	DB
			Dimensions according to DIN [mm]							
<b>IE2</b>			n	d	l	u		t	d6/d7	
DOR63M1, M2	63	2...4	94	27,5	11	23	4	4	12,5	M4
DOR71M1, M2	71	2...4	94	32	14	30	5	5	16	M4
DOR80M1, M2	80	2...6	105	41	19	40	6	6	21,5	M6
DOR90S	90S	2...8	105	45,5	24	50	8	7	27	M8
DOR90L	90L	2...8	105	35	24	50	8	7	27	M8
DOR100L, L1, L2	100L	2...8	105	50	28	60	8	7	31	M10
DOR112M	112M	2...8	112	55	28	60	8	7	31	M10
DOR132S, S1, S2	132S	2...8	112	58	38	80	10	8	41	M12
DOR132M, M1, M2	132M	2...8	112	58	38	80	10	8	41	M12
DOR160M, M1, M2	160M	2...8	143	55	42	110	12	8	45	M16
DOR160L	160L	2...8	155	55	42	110	12	8	45	M16

Mounting arrangement IM 2001 (B35), IM 3001 (B5) without feet

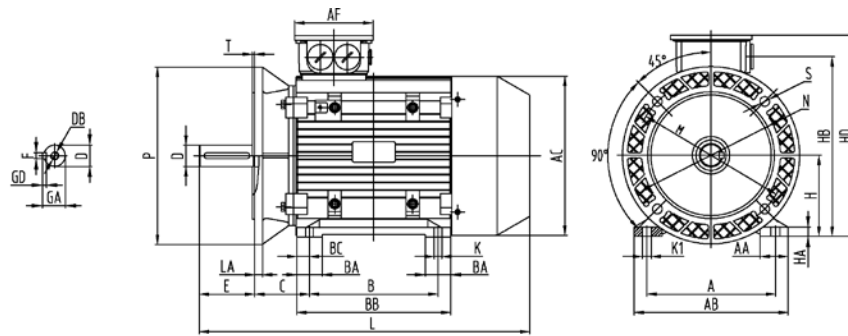

Mounting arrangement IM (B34), IM 3601 (B14) without feet

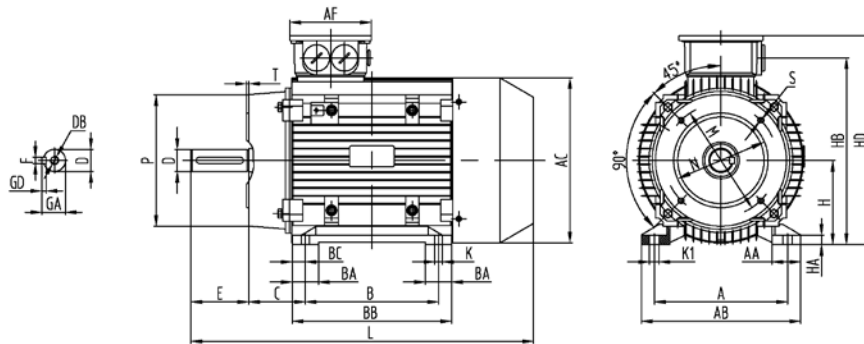

Type	Frame size	No. of poles	Flange B5						Small flange B14					Big flange B14				
			Dimensions according to IEC [mm]															
			M	N	P	T	LA	S <sup>1)</sup>	M	N	P	T	S	M	N	P	T	S
			Dimensions according to DIN [mm]															
<b>IE2</b>			e1	b1	a1	f1	c1	s1 <sup>1)</sup>	e1	b1	a1	f1	s1	e1	b1	a1	f1	s1
DOR63M1, M2	63	2..4	115	95	140	3	10	4 x M8	75	60	90	2,5	4 x M5	100	80	120	3	4 x M6
DOR71M1, M2	71	2..4	130	110	160	3,5	10	4 x M8	85	70	105	2,5	4 x M6	115	95	140	3	4 x M8
DOR80M1, M2	80	2..6	165	130	200	3,5	12	4 x M10	100	80	120	3	4 x M6	130	110	160	3,5	4 x M8
DOR90S	90S	2..8	165	130	200	3,5	12	4 x M10	115	95	140	3	4 x M8	130	110	160	3,5	4 x M8
DOR90L	90L	2..8	165	130	200	3,5	12	4 x M10	115	95	140	3	4 x M8	130	110	160	3,5	4 x M8
DOR100L, L1, L2	100L	2..8	215	180	250	4	13	4 x M12	130	110	160	3,5	4 x M8	165	130	200	3,5	4 x M10
DOR112M	112M	2..8	215	180	250	4	14	4 x M12	130	110	160	3,5	4 x M8	165	130	200	3,5	4 x M10
DOR132S, S1, S2	132S	2..8	265	230	300	4	14	4 x M12	165	130	200	3,5	4 x M10	215	180	250	4	4 x M12
DOR132M, M1, M2	132M	2..8	265	230	300	4	14	4 x M12	165	130	200	3,5	4 x M10	215	180	250	4	4 x M12
DOR160M, M1, M2	160M	2..8	300	250	350	5	15	4 x M16	-	-	-	-	-	-	-	-	-	-
DOR160L	160L	2..8	300	250	350	5	15	4 x M16	-	-	-	-	-	-	-	-	-	-

<sup>1)</sup> Through hole, suitable for screws

## Technical data IE3

Type	Frame size	Ratings for mains operation										For direct-on-line starting		
		Rated power	Rated speed	Rated torque	Efficiency class acc. to EN 60034-30			Power factor	Rated current at		Starting current	Starting torque	Break-down torque	
		$P_N$ [kW]	$n_N$ [min <sup>-1</sup> ]	$T_N$ [Nm]	Efficiency EN60034-2-1 : 2007				$I_N$ [A]					
					$\eta$ [%]			$\cos \varphi$	400V	380... 420V	$I_s/I_N$	$T_s/T_N$	$T_B/T_N$	

Helmke DOR – aluminium Motors

**IE3**

### 3000 min<sup>-1</sup> (2-pole)

DOR80M1-02-3A	80	0,75	2890	2,47	<b>IE3</b>	80,7	80,5	78,1	0,81	2,88	3,02	7,3	3,1	3,2
DOR80M2-02-3A	80	1,1	2890	3,63	<b>IE3</b>	82,7	82,6	80,3	0,82	4	4,2	8,1	3,4	3,5
DOR90S-02-3A	90	1,5	2900	4,9	<b>IE3</b>	84,2	84,1	81,9	0,82	5,4	5,7	8,4	3,6	3,9
DOR90L-02-3A	90	2,2	2910	7,2	<b>IE3</b>	85,9	85,8	83,8	0,83	7,7	8,1	8,7	3,3	3,4
DOR100L-02-3A	100	3	2910	9,8	<b>IE3</b>	87,1	87	85,2	0,88	5,6	5,9	9,3	3,2	3,6
DOR112M-02-3A	112	4	2920	13	<b>IE3</b>	88,1	88	86,3	0,9	7,2	7,6	11	3,5	4
DOR132S1-02-3A	132	5,5	2930	17,9	<b>IE3</b>	89,2	89,1	87,5	0,89	9,9	10,4	9,9	3,2	4,1
DOR132S2-02-3A	132	7,5	2930	24,4	<b>IE3</b>	90,1	90	88,6	0,9	13,3	14	12	3,9	5,2
DOR160M1-02-3A	160	11	2950	35,6	<b>IE3</b>	91,2	91,1	89,8	0,88	19,7	20,7	11	3,7	3
DOR160M2-02-3A	160	15	2960	48,3	<b>IE3</b>	91,9	91,8	90,6	0,89	26,4	27,7	11	3,9	3
DOR160L-02-3A	160	18,5	2965	59,5	<b>IE3</b>	92,4	92,3	91,2	0,89	32,4	34	9	3	3

### 1500 min<sup>-1</sup> (4- polig)

DOR80M2-04-3A	80	0,75	1430	5	<b>IE3</b>	82,5	82,4	80	0,7	3,26	3,42	6,2	3,1	3,1
DOR90S-04-3A	90	1,1	1440	7,2	<b>IE3</b>	84,1	84	81,8	0,72	4,5	4,7	6,7	3,1	3,1
DOR90L-04-3A	90	1,5	1440	9,9	<b>IE3</b>	85,3	85,2	83,2	0,71	6,2	6,5	7,2	3,9	3,7
DOR100L1-04-3A	100	2,2	1450	14,4	<b>IE3</b>	86,7	86,6	84,7	0,82	7,7	8,1	7,9	3	3,5
DOR100L2-04-3A	100	3	1450	19,7	<b>IE3</b>	87,7	87,6	85,9	0,78	6,3	6,6	8,1	3,4	3,5
DOR112M-04-3A	112	4	1450	26,3	<b>IE3</b>	88,6	88,5	86,9	0,82	7,9	8,3	8,5	3,1	3,8
DOR132S-04-3A	132	5,5	1460	35,9	<b>IE3</b>	89,6	89,5	88	0,84	10,5	11	9	2,3	3,5
DOR132M-04-3A	132	7,5	1460	49	<b>IE3</b>	90,4	90,3	88,9	0,85	14	14,7	8,7	2,9	3,5
DOR160M-04-3A	160	11	1465	71,7	<b>IE3</b>	91,4	91,3	90	0,84	16,5	17,3	8,5	2,9	3
DOR160L-04-3A	160	15	1465	97,7	<b>IE3</b>	92,1	92	90,8	0,85	27,6	29	8,7	2,8	3

### 1000 min<sup>-1</sup> (6-polig)

DOR90S-06-3A	90	0,75	945	7,5	<b>IE3</b>	78,9	78,7	76,1	0,67	3,56	3,73	4,4	2,1	2,5
DOR90L-06-3A	90	1,1	950	11	<b>IE3</b>	81	80,8	78,4	0,67	5	5,3	5,2	2,8	3
DOR100L-06-3A	100	1,5	950	15	<b>IE3</b>	82,5	82,4	80	0,71	6,4	6,7	5	2,1	2,6
DOR112M-06-3A	112	2,2	960	21,8	<b>IE3</b>	84,3	84,2	82	0,72	9	9,5	5,3	2,6	2,6
DOR132S-06-3A	132	3	965	29,6	<b>IE3</b>	85,6	85,5	83,5	0,74	6,8	7,1	5,9	2	2,7
DOR132M1-06-3A	132	4	970	39,3	<b>IE3</b>	86,8	86,7	84,8	0,74	8,9	9,4	6,8	2,4	3,1
DOR132M2-06-3A	132	5,5	970	54,1	<b>IE3</b>	88	87,9	86,2	0,71	12,7	13,3	7,4	2,9	3,6
DOR160M-06-3A	160	7,5	975	73,4	<b>IE3</b>	89,1	89	87,4	0,76	15,9	16,7	7,3	2,8	3
DOR160L-06-3A	160	11	975	107	<b>IE3</b>	90,3	90,2	88,8	0,78	18	18,9	8,4	2,7	3

Type	Ratings for operation with IGBT converter									Inertia J [10 <sup>-3</sup> kgm <sup>2</sup> ]	Weight [kg]
	T ~ n <sup>2</sup> , self-ventilated or T = constant, forced-ventilated			T = constant, self-ventilated			T = constant, self-ventilated				
	Speed range 5...50 Hz			Speed range 17...50 Hz			Speed range 5...50 Hz				
P at 50 Hz [kW]	I [A]	Temp. class	P at 50 Hz [kW]	T [Nm]	I [A]	P at 50 Hz [kW]	T [Nm]	I [A]	J	Weight	

Helmke DOR – aluminium motors

**IE3**

3000 min<sup>-1</sup> (2-pole)

DOR80M1-02-3A	0,75	3,02	F	0,63	2,08	2,56	0,54	1,78	2,17	0,9	8,7
DOR80M2-02-3A	1,1	4,2	F	0,93	3,07	3,57	0,79	2,61	3,02	1,1	10
DOR90S-02-3A	1,5	5,7	F	1,27	4,1	4,8	1,08	3,55	4,1	2,2	14
DOR90L-02-3A	2,2	8,1	F	1,87	6,1	6,8	1,58	5,1	5,8	2,7	16
DOR100L-02-3A	3	5,9	F	2,55	8,3	5	2,16	7	4,2	4,7	23
DOR112M-02-3A	4	7,6	F	3,4	11,1	6,4	2,88	9,4	5,4	6,6	30
DOR132S1-02-3A	5,5	10,4	F	4,6	14,9	8,8	3,96	12,9	7,4	15,5	44
DOR132S2-02-3A	7,5	14	F	6,3	20,5	11,9	5,4	17,6	10	19,1	53
DOR160M1-02-3A	11	20,7	F	9,3	30,1	17,5	7,9	25,5	14,9	58,5	93
DOR160M2-02-3A	15	27,7	F	12,7	40,9	23,5	10,8	34,8	19,9	69,3	93
DOR160L-02-3A	18,5	34	F	15,7	50,5	28,9	13,3	42,8	24,4	78,6	134

1500 min<sup>-1</sup> (4-polig)

DOR80M2-04-3A	0,75	3,42	F	0,57	3,8	2,59	0,46	3,07	2,13	2,3	11
DOR90S-04-3A	1,1	4,7	F	0,83	5,5	3,57	0,68	4,5	2,93	3,3	15
DOR90L-04-3A	1,5	6,5	F	1,14	7,5	4,9	0,93	6,1	4	4,2	18
DOR100L1-04-3A	2,2	8,1	F	1,67	10,9	6,1	1,37	9	5	8	23
DOR100L2-04-3A	3	6,6	F	2,28	15	5	1,87	12,3	4,1	9,5	28
DOR112M-04-3A	4	8,3	F	3,04	20	6,3	2,5	16,4	5,1	12,6	32
DOR132S-04-3A	5,5	11	F	4,1	26,8	8,3	3,43	22,4	6,8	31,7	49
DOR132M-04-3A	7,5	14,7	F	5,7	37,2	11,1	4,6	30	9,1	38,9	53
DOR160L-04-3A	15	29	F	11,4	74,3	22	9,3	60,6	18,1	89,8	125
DOR160L-04-3A	15	29	F	11,4	74,3	22	9,3	60,6	18,1	115	125

1000 min<sup>-1</sup> (6-polig)

DOR90S-06-3A	0,75	3,73	F	0,57	5,7	2,83	0,46	4,6	2,33	4,2	14
DOR90L-06-3A	1,1	5,3	F	0,83	8,3	4	0,68	6,8	3,31	5,7	17
DOR100L-06-3A	1,5	6,7	F	1,14	11,4	5	0,93	9,3	4,1	7,8	21
DOR112M-06-3A	2,2	9,5	F	1,67	16,6	7,2	1,37	13,6	5,9	17,9	23
DOR132S-06-3A	3	7,1	F	2,28	22,5	5,3	1,87	18,5	4,4	30,9	28
DOR132M1-06-3A	4	9,4	F	3,04	29,9	7,1	2,5	24,6	5,8	38,9	42
DOR132M2-06-3A	5,5	13,3	F	4,1	40,3	10,1	3,43	33,7	8,3	46,7	54
DOR160M-06-3A	7,5	13,4	F	5,7	55,8	10,1	4,6	45	8,3	92,7	90
DOR160L-06-3A	11	23,6	F	8,3	81,2	17,9	6,8	66,6	14,7	121	119

**Dimensions IE3**

Mounting arrangement IM 1001 (B3)

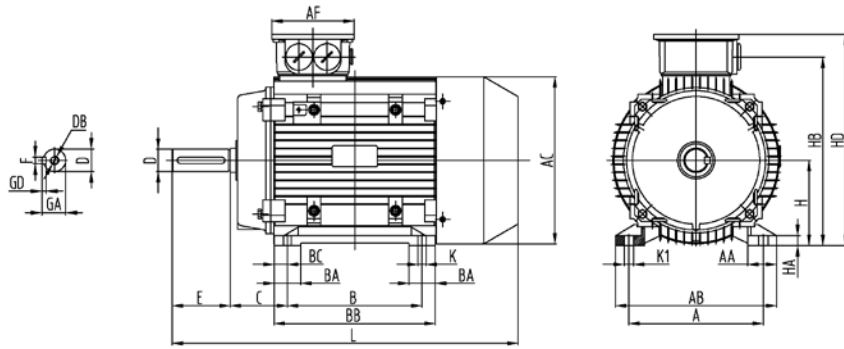

Type	Frame size	No. of poles	Dimensions according to IEC [mm]													
			H	A	B	C	AB	BB	BC	HD	AC	HB	HA	K	K1	L
			Dimensions according to DIN [mm]													
<b>IE3</b>			h	b	a	w1	f	e		m1	g	v	c	s		k
DOR80M1, M2	80	2...6	80	125	100	50	160	125	12,5	209	158	182	11	9	16	277
DOR90S	90S	2...6	90	140	100	56	175	130	12,5	228	177	201	13	8,8	12,8	312
DOR90L	90L	2...6	90	140	125	56	175	155	12,5	228	177	201	13	8,8	12,8	337
DOR100L, L1, L2	100L	2...6	100	160	140	63	200	160	20	258	200	225	14	10	16	380
DOR112M	112M	2...6	112	190	140	70	226	180	20	280	220	249	14	12	16	400
DOR132S, S1, S2	132S	2...6	132	216	140	89	255	190	25	319	261	288	16	12	16	460
DOR132M, M1, M2	132M	2...6	132	216	178	89	255	228	25	319	261	288	16	12	16	500
DOR160M, M1, M2	160M	2...6	160	254	210	108	314	261	25,5	385	313	350	20	15	19	625
DOR160L	160L	2...6	160	254	254	108	314	305	25,5	385	313	350	20	15	19	669

Type	Frame size	No. of poles	Dimensions according to IEC [mm]							
			AF	AA	D	E	F	GD	GA	DB
			Dimensions according to DIN [mm]							
<b>IE3</b>			n	d	l	u		t	d6/d7	
DOR80M1, M2	80	2...6	105	35	19	40	6	6	21,5	M6
DOR90S	90S	2...6	105	35	24	50	8	7	27	M8
DOR90L	90L	2...6	105	35	24	50	8	7	27	M8
DOR100L, L1, L2	100L	2...6	112	45	28	60	8	7	31	M10
DOR112M	112M	2...6	112	43	28	60	8	7	31	M10
DOR132S, S1, S2	132S	2...6	112	44	38	80	10	8	41	M12
DOR132M, M1, M2	132M	2...6	112	44	38	80	10	8	41	M12
DOR160M, M1, M2	160M	2...6	143	60	42	110	12	8	45	M16
DOR160L	160L	2...6	143	60	42	110	12	8	45	M16

Mounting arrangement IM 2001 (B35), IM 3001 (B5) without feet

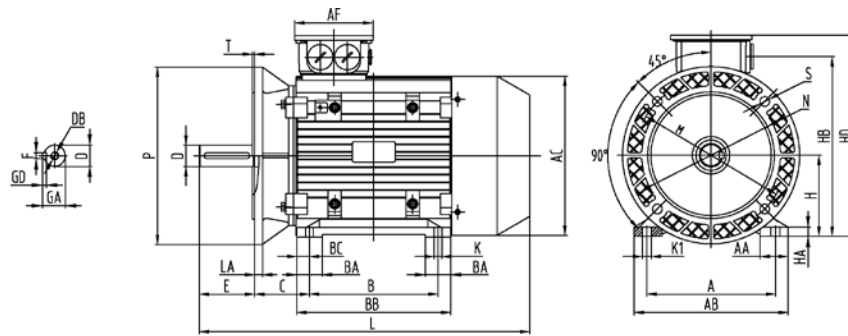

Mounting arrangement IM (B34), IM 3601 (B14) without feet

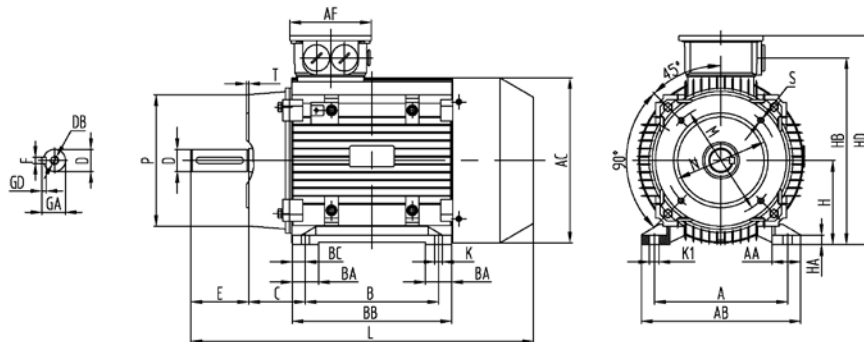

Type	Frame size	No. of poles	Flange B5						Small flange B14					Big flange B14				
			Dimensions according to IEC [mm]															
			M	N	P	T	LA	S <sup>1)</sup>	M	N	P	T	S	M	N	P	T	S
			Dimensions according to DIN [mm]															
<b>IE3</b>			e1	b1	a1	f1	c1	s1 <sup>1)</sup>	e1	b1	a1	f1	s1	e1	b1	a1	f1	s1
DOR80M1, M2	80	2..6	165	130	200	3,5	12	4 x M10	100	80	120	3	4 x M6	130	110	160	3,5	4 x M8
DOR90S	90S	2..6	165	130	200	3,5	12	4 x M10	115	95	140	3	4 x M8	130	110	160	3,5	4 x M8
DOR90L	90L	2..6	165	130	200	3,5	12	4 x M10	115	95	140	3	4 x M8	130	110	160	3,5	4 x M8
DOR100L, L1, L2	100L	2..6	215	180	250	4	13	4 x M12	130	110	160	3,5	4 x M8	165	130	200	3,5	4 x M10
DOR112M	112M	2..6	215	180	250	4	14	4 x M12	130	110	160	3,5	4 x M8	165	130	200	3,5	4 x M10
DOR132S, S1, S2	132S	2..6	265	230	300	4	14	4 x M12	165	130	200	3,5	4 x M10	215	180	250	4	4 x M12
DOR132M, M1, M2	132M	2..6	265	230	300	4	14	4 x M12	165	130	200	3,5	4 x M10	215	180	250	4	4 x M12
DOR160M, M1, M2	160M	2..6	300	250	350	5	15	4 x M16	-	-	-	-	-	-	-	-	-	-
DOR160L	160L	2..6	300	250	350	5	15	4 x M16	-	-	-	-	-	-	-	-	-	-

<sup>1)</sup> Through hole, suitable for screws





## Cast Iron Motors

Range of motors in cast iron frame, standard-like with lubricator, PTC thermistor temperature sensor in the stator winding, additional external protective conductor connection, available on short term in 2, 4, 6 and 8-pole design up to frame size 355.

### Overview cast iron motors

Type	Frame size	Rated power [kW]			
		2-pole	4-pole	6-pole	8-pole
DOR63M1	63	0,18	0,12	–	–
DOR63M2	63	0,25	0,18	–	–
DOR71M1	71	0,37	0,25	0,18	–
DOR71M2	71	0,55	0,37	0,25	–
DOR80M1	80	0,75	0,55	0,37	0,18
DOR80M2	80	1,1	0,75	0,55	0,25
DOR90S	90S	1,5	1,1	0,75	0,37
DOR90L	90L	2,2	1,5	1,1	0,55
DOR100L, L1	100L	3,0	2,2	1,5	0,75
DOR100L2	100L	–	3,0	–	1,1
DOR112M	112M	4,0	4,0	2,2	1,5
DOR132S1	132S	5,5	–	–	–
DOR132S, S2	132S	7,5	5,5	3,0	2,2
DOR132M1	132M	–	–	4,0	–
DOR132M, M2	132M	–	7,5	5,5	3,0
DOR160M1	160M	11	–	–	4,0
DOR160M, M2	160M	15	11	7,5	5,5
DOR160L	160L	18,5	15	11	7,5
DOR180M	180M	22	18,5	–	–
DOR180L	180L	–	22	15	11
DOR200L1	200L	30	–	18,5	–
DOR200L, L2	200L	37	30	22	15
DOR225S	225S	–	37	–	18,5
DOR225M	225M	45	45	30	22
DOR250M	250M	55	55	37	30
DOR280S	280S	75	75	45	37
DOR280M	280M	90	90	55	45
DOR315S	315S	110	110	75	55
DOR315M	315M	132	132	90	75
DOR315L1	315L	160	160	110	90
DOR315L2	315L	200	200	132	110
DOR355M, M1	355M	250	250	160	132
DOR355M2	355M	–	–	200	160
DOR355L	355L	315	315	250	200

#### General data

- Voltage/Connection                      up to 2,2 kW:    230 V Δ / 400 V Y  
     from 3,0 kW:    400 V Δ / 690 V Y
- Mounting arrangements                    IM 1001 (B3), IM 3001 (B5), IM 3601 (B14) feet can be mounted on flange-mounted motors
- Thermistor                                    3 PTC built-in standard-like

## Terminal box

Frame size	Degree of protection	Hole for cable entry	Connection for temperature sensor	Max. conductor cross section [mm <sup>2</sup> ]	Connecting bolt	Max. external cable diameter [mm]
		Metric	Metric			
63	IP 55	1 x M20x1,5	1 x M20x1,5	2,5	M4	13
71	IP 55	1 x M20x1,5	1 x M20x1,5	2,5	M4	13
80	IP 55	1 x M20x1,5	1 x M20x1,5	2,5	M4	13
90	IP 55	1 x M20x1,5	1 x M20x1,5	2,5	M4	13
100	IP 55	1 x M20x1,5	1 x M20x1,5	2,5	M4	13
112	IP 55	2 x M32x1,5	1 x M20x1,5	4	M4	21
132	IP 55	2 x M32x1,5	1 x M20x1,5	4	M4	21
160	IP 55	2 x M40x1,5	1 x M25x1,5	16	M5	27
180	IP 55	2 x M40x1,5	1 x M25x1,5	16	M5	27
200	IP 55	2 x M50x1,5 <sup>1)</sup>	1 x M25x1,5	50	M6	35
225	IP 55	2 x M50x1,5 <sup>1)</sup>	1 x M25x1,5	50	M8	35
250	IP 55	2 x M63x1,5 <sup>1)</sup>	1 x M25x1,5	95	M10	48
280	IP 55	2 x M63x1,5 <sup>1)</sup>	1 x M25x1,5	95	M10	48
315	IP 55	2 x M63x1,5 <sup>1)</sup>	1 x M25x1,5	185	M12	48
355	IP 55	2 x M72x2 <sup>1)</sup>	1 x M25x1,5	300	M16	52

<sup>1)</sup> Terminal box with unscrewable cable entry plate

## Materials

Designation	Frame size	Material
Stator frame	63...355	Cast iron
End shield	63...355	Cast iron
Flanged endshield	63...355	Cast iron
Fan cover	63...355	Sheet steel
Fan	63...355	Plastic material
Terminal box	63...355	Cast iron

## Bearings

Allocation of bearings (standard design)

Ball bearings according to ISO 15 (DIN 625)

Frame size	No. of poles	Drive end	Non-drive end
63	2...8	6201-2Z C3	6201-2Z C3
71	2...8	6202-2Z C3	6202-2Z C3
80	2...8	6204-2Z C3	6204-2Z C3
90	2...8	6205-2Z C3	6205-2Z C3
100	2...8	6206-2Z C3	6206-2Z C3
112	2...8	6306-2Z C3	6306-2Z C3
132	2...8	6308-2Z C3	6308-2Z C3
160	2...8	6309-2Z C3	6309-2Z C3
180	2...8	6311-C3	6311-C3
200	2...8	6312-C3	6312-C3
225	2...8	6313-C3	6313-C3
250	2...8	6314-C3	6314-C3
280	2	6314-C3	6314-C3
	4...8	6317-C3	6317-C3
315	2	6317-C3	6317-C3
	4...8	6319-C3	6319-C3
355	2 (hor.)	6317-C3	6317-C3
	4...8 (hor.)	NU322E	6320-C3
	2 (vert.)	6317-C3	7317B
	4...8 (vert.)	6322-C3	7320B

Standard design of bearings

(other designs on request)

Frame size	Bearing drive end	Bearing non-drive end	Spring-loaded
63...160	Located bearing	Non-located bearing	Non-drive end
180...355	Non-located bearing	Located bearing	Drive end



For motors from size 280 we recommend an insulated bearing on the non-drive end for converter operation.

*Maximum permissible axial loads without additional radial load*

Values are valid for 50 Hz. For 60 Hz operation the values have to be reduced by 10%. (if additional radial forces affect, enquiry is necessary depending on the direction of force)

*Horizontal shaft*

Frame size	Axial load thrust [kN]				Axial load tension [kN]			
	3000 min <sup>-1</sup>	1500 min <sup>-1</sup>	1000 min <sup>-1</sup>	750 min <sup>-1</sup>	3000 min <sup>-1</sup>	1500 min <sup>-1</sup>	1000 min <sup>-1</sup>	750 min <sup>-1</sup>
63	0,25	0,28	–	–	0,25	0,28	–	–
71	0,27	0,35	0,44	–	0,27	0,35	0,44	–
80	0,38	0,47	0,59	0,62	0,38	0,47	0,59	0,62
90	0,44	0,55	0,62	0,64	0,44	0,55	0,62	0,64
100	0,61	0,75	0,88	0,89	0,61	0,75	0,88	0,89
112	1,22	1,44	1,65	1,78	1,22	1,44	1,65	1,78
132	1,50	1,78	1,82	1,92	1,50	1,78	1,82	1,92
160	1,65	2,10	2,45	2,65	1,65	2,10	2,45	2,65
180	2,10	2,60	2,90	3,17	2,10	2,60	2,90	3,17
200	2,40	3,12	3,48	3,95	2,40	3,12	3,48	3,95
225	2,72	3,48	3,89	4,33	2,72	3,48	3,89	4,33
250	3,10	3,90	4,45	4,98	3,10	3,90	4,45	4,98
280	5,30	6,30	6,70	7,10	3,10	4,40	4,30	5,02
315	5,90	7,10	7,60	8,10	3,80	5,10	5,80	3,60
355	6,10	9,80	10,50	12,50	1,85	3,90	4,70	6,00

*Vertical shaft downwards*

Frame size	Axial load upwards [kN]				Axial load downwards [kN]			
	3000 min <sup>-1</sup>	1500 min <sup>-1</sup>	1000 min <sup>-1</sup>	750 min <sup>-1</sup>	3000 min <sup>-1</sup>	1500 min <sup>-1</sup>	1000 min <sup>-1</sup>	750 min <sup>-1</sup>
63	0,26	0,30	–	–	0,23	0,26	–	–
71	0,29	0,37	0,46	–	0,25	0,32	0,42	–
80	0,40	0,49	0,62	0,65	0,36	0,45	0,56	0,59
90	0,47	0,60	0,68	0,70	0,41	0,51	0,46	0,58
100	0,67	0,84	0,97	0,97	0,57	0,71	0,82	0,84
112	1,30	1,52	1,74	1,88	1,17	1,37	1,58	1,71
132	1,62	1,97	2,00	2,10	1,43	1,61	1,66	1,76
160	1,95	2,47	2,80	3,05	1,35	1,72	2,05	2,21
180	2,45	3,20	3,51	3,78	1,72	2,00	2,28	2,55
200	2,94	3,85	4,35	4,81	1,84	2,39	2,61	3,09
225	3,42	4,37	5,04	5,33	2,02	2,59	2,82	3,33
250	3,94	5,00	5,57	6,38	2,26	2,80	3,32	3,58
280	6,50	7,80	7,90	9,10	2,10	3,00	2,90	3,52
315	8,00	10,70	11,80	12,50	2,00	3,15	3,50	4,40
355	14,00	18,30	20,70	21,50	0,80	2,50	3,50	3,60

Permissible radial loads

without additional axial load (ball bearing)

max. permissible radial loads in the table are valid for  
 $X = 1/2$  shaft length

Frame size	F <sub>R</sub> in N for number of poles			
	2	4	6	8
63	300	300	–	–
71	400	400	400	–
80	610	650	750	820
90S/L	660	710	810	890
100L	920	990	1130	1240
112M	1330	1430	1640	1800

F<sub>R</sub> = permissible radial load in kN (without additional axial load)

X = Distance between working point of force and shaft shoulder (e.g. half pulley width)

For calculation of the radial forces see *Belt drive* on page 9.

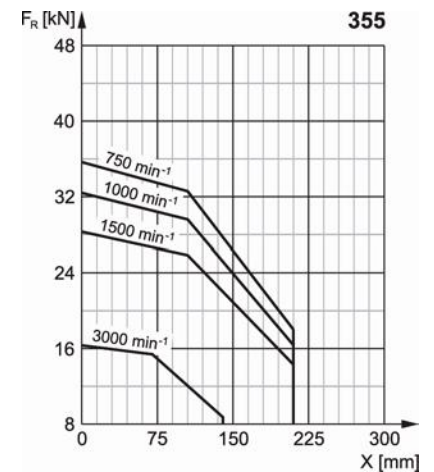
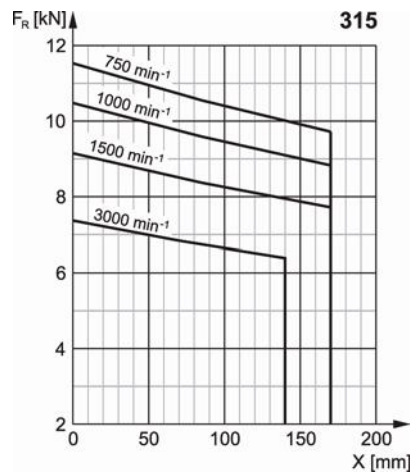
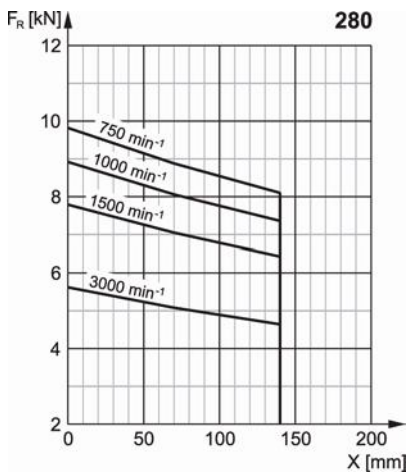
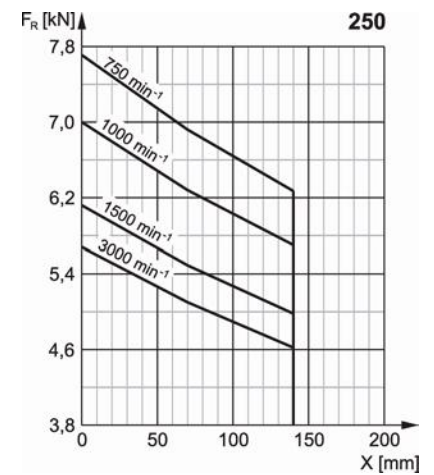
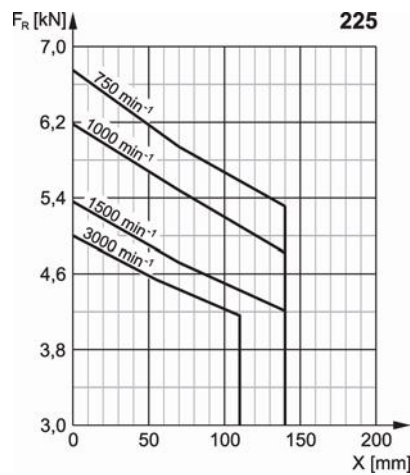
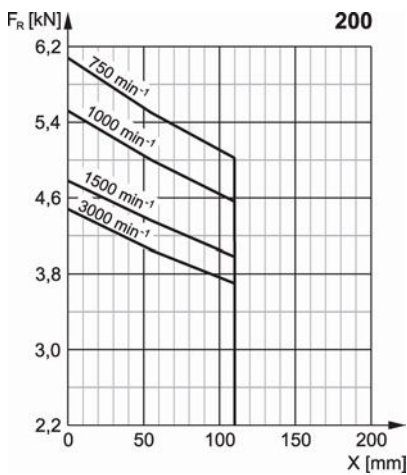
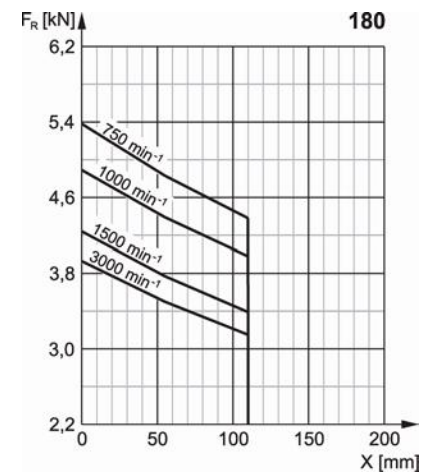
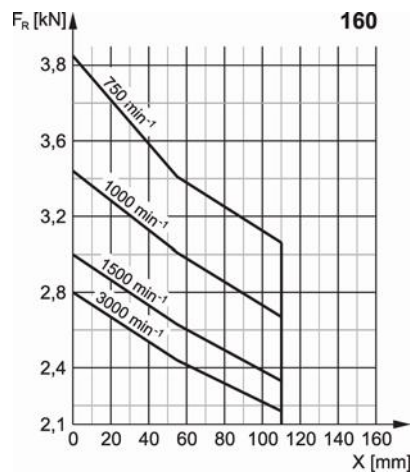
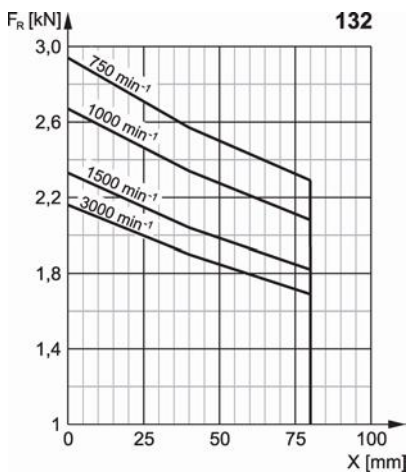

### Anti-condensation heating

Motors which are exposed to a risk of humidity during standstill due to severe temperature variations can be equipped with anti-condensation heating (strip heaters) for an extra charge, if requested.

The supply voltage and the heating power of the strip heaters can be taken from the table beside.

Frame size	Supply voltage [V]	Heizleistung/Motor [W]
132...200	230	2x40
225...250	230	2 x 50
280...315	230	2 x 65
355	230	2 x 100



During operation of the motor, the anti-condensation heating must be switched off.

### Noise characteristics

The noise values listed beside are valid for 50 Hz at rated voltage with a tolerance of up to +3 dB(A).

3...5 dB(A) higher values are the recommended values for operation at 60 Hz.

Frame size	Sound pressure level $L_{pa}$ [dB(A)]			
	2-pole	4-pole	6-pole	8-pole
71	53	44	40	37
80	56	47	41	40
90	60	49	45	41
100	64	53	49	44
112	65	54	53	48
132	68	62	63	50
160	74	66	66	54
180	77	67	66	56
200	80	70	69	59
225	81	72	69	59
250	82	73	71	61
280	83	77	73	62
315S/M	85	84	78	68
315L	88	88	78	68
355M	92	92	85	76
355L	93	92	85	78

**Position and dimensions of the key**

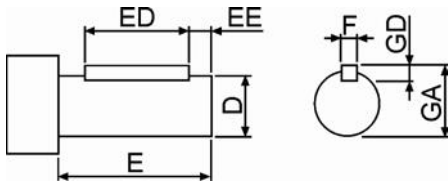

Frame size	Dimensions [mm]				
	D X E	F X GD	ED	EE	GA
71	14 X 30	5 X 5	25	2,5	16
80	19 X 40	6 X 6	30	5	21,5
90	24 X 50	8 X 7	40	5	27
100	28 X 60	8 X 7	50	5	31
112	28 X 60	8 X 7	50	5	31
132	38 X 80	10 X 8	65	7,5	41
160	42 X 110	12 X 8	90	10	45
180	48 x 110	14 x 9	73	16	51,5
200	55 x 110	16 x 10	81	10	59
225	55 x 110	16 x 10	84	12	59
	60 x 140	18 x 11	112	14	64
250	60 x 140	18 x 11	112	14	64
	65 x 140	18 x 11	112	14	69
280	65 x 140	18 x 11	112	14	69
	75 x 140	20 x 12	112	14	79,5
315	65 x 140	18 x 11	124	8	69
	80 x 170	22 x 14	152	8	85
355	75 x 140	20 x 12	112	14	79,5
	100 x 210	28 x 16	154	7	106



For longer shafts in special design the dimensions ED and EE are kept.

## Technical Data IE2

Type	Frame size	Ratings for mains operation								For direct-on-line starting				
		Rated power	Rated speed	Rated torque	Efficiency class acc. to EN 60034-30	Efficiency EN60034-2-1 : 2007			Power factor	Rated current at		Starting current	Starting torque	Break-down torque
		$P_N$ [kW]	$n_N$ [min <sup>-1</sup> ]	$T_N$ [Nm]		$\eta$ [%]	$\cos \varphi$	$I_N$ [A]		$I_s/I_N$	$T_s/T_N$			
						100%	75%	50%		400V	380... 420V			

Helmke DOR – cast iron motors

**IE2**

### 3000 min-1 (2-pole)

DOR63M1-02-1G	63	0,18	2720	0,63		65,0	64,8	61,2	0,80	0,49	0,52	5,5	2,2	2,2
DOR63M2-02-1G	63	0,25	2720	0,87		68,0	67,8	64,4	0,81	0,65	0,68	5,5	2,2	2,2
DOR71M1-02-1G	71	0,37	2740	1,28		70,0	69,8	66,5	0,81	0,94	0,98	6,1	2,2	2,2
DOR71M2-02-1G	71	0,55	2740	1,91		73,0	72,8	69,7	0,82	1,32	1,39	6,1	2,2	2,3
DOR80M1-02-2G	80	0,75	2845	2,51	<b>IE2</b>	77,4	77,2	74,5	0,83	1,68	1,76	7,0	2,2	2,3
DOR80M2-02-2G	80	1,1	2845	3,69	<b>IE2</b>	79,6	79,4	76,9	0,84	2,37	2,49	7,9	2,2	2,3
DOR90S-02-2G	90	1,5	2840	5	<b>IE2</b>	81,3	81,1	78,7	0,84	3,17	3,32	7,9	2,2	2,3
DOR90L-02-2G	90	2,2	2840	7,3	<b>IE2</b>	83,2	83,1	80,8	0,85	4,4	4,7	7,9	2,2	2,3
DOR100L-02-2G	100	3	2865	10	<b>IE2</b>	84,6	84,5	82,4	0,87	5,8	6,1	7,9	2,2	2,3
DOR112M-02-2G	112	4	2865	13,3	<b>IE2</b>	85,8	85,7	83,7	0,88	7,6	8	8,1	2,2	2,3
DOR132S1-02-2G	132	5,5	2900	18,1	<b>IE2</b>	87,0	86,9	85,1	0,86	10,6	11,1	8,1	2,2	2,3
DOR132S2-02-2G	132	7,5	2900	24,6	<b>IE2</b>	88,1	88,0	86,3	0,88	13,9	14,6	8,1	2,2	2,3
DOR160M1-02-2G	160	11	2930	35,8	<b>IE2</b>	89,4	89,3	87,8	0,89	19,9	20,9	8,1	2,2	2,3
DOR160M2-02-2G	160	15	2930	48,8	<b>IE2</b>	90,3	90,2	88,8	0,89	26,9	28,2	8,1	2,2	2,3
DOR160L-02-2G	160	18,5	2930	60,2	<b>IE2</b>	90,9	90,8	89,5	0,89	33	34,6	8,1	2,2	2,3
DOR180M-02-2G	180	22	2940	71,4	<b>IE2</b>	91,3	91,2	89,9	0,88	39,5	41,4	8,1	2,0	2,3
DOR200L1-02-2G	200	30	2950	97,1	<b>IE2</b>	92,0	91,9	90,7	0,88	53,4	56,1	8,1	2,0	2,3
DOR200L2-02-2G	200	37	2950	119	<b>IE2</b>	92,5	92,4	91,3	0,89	64,8	68,1	8,1	2,0	2,3
DOR225M-02-2G	225	45	2960	145	<b>IE2</b>	92,9	92,8	91,8	0,89	78,5	82,4	8,1	2,0	2,3
DOR250M-02-2G	250	55	2965	177	<b>IE2</b>	93,2	93,1	92,1	0,90	94,6	99,3	8,1	2,0	2,3
DOR280S-02-2G	280	75	2960	241	<b>IE2</b>	93,8	93,7	92,8	0,90	128	134	7,5	2,0	2,3
DOR280M-02-2G	280	90	2960	290	<b>IE2</b>	94,1	94,0	93,1	0,91	151	159	7,5	2,0	2,3
DOR315S-02-2G	315	110	2975	353	<b>IE2</b>	94,3	94,2	93,4	0,90	187	196	7,8	2,1	3,2
DOR315M-02-2G	315	132	2975	423	<b>IE2</b>	94,6	94,5	93,7	0,90	223	234	7,8	2,1	3,2
DOR315L1-02-2G	315	160	2975	513	<b>IE2</b>	94,8	94,8	93,9	0,89	273	287	8,0	2,1	3,2
DOR315L2-02-2G	315	200	2975	642	<b>IE2</b>	95,0	95,0	94,2	0,89	341	358	8,0	2,1	3,2
DOR355M-02-2G	355	250	2980	801	<b>IE2</b>	95,0	95,0	94,2	0,92	412	433	7,8	1,6	2,0
DOR355L-02-2G	355	315	2980	1009	<b>IE2</b>	95,0	95,0	94,2	0,92	520	546	7,8	1,6	2,2



Type	Ratings for operation with IGBT converter									Inertia J [10 <sup>-3</sup> kgm <sup>2</sup> ]	Weight [kg]
	T ~ n <sup>2</sup> , self-ventilated or T = constant, forced-ventilated Speed range 5...50 Hz			T = constant, self-ventilated Speed range 17...50 Hz			T = constant, self-ventilated Speed range 5...50 Hz				
	P at 50 Hz [kW]	I [A]	Temp. class	P at 50 Hz [kW]	T [Nm]	I [A]	P at 50 Hz [kW]	T [Nm]	I [A]		

Helmke DOR – cast iron motors

**IE2**

3000 min-1 (2-pole)

DOR63M1-02-1G	0,18	0,52	F	0,15	0,52	0,44	0,12	0,42	0,37	0,18	12
DOR63M2-02-1G	0,25	0,68	F	0,21	0,73	0,57	0,18	0,63	0,48	0,19	13
DOR71M1-02-1G	0,37	0,98	F	0,31	1,08	0,83	0,26	0,9	0,7	0,3	14
DOR71M2-02-1G	0,55	1,39	F	0,46	1,6	1,18	0,39	1,35	1	0,35	15
DOR80M1-02-2G	0,75	1,76	F	0,63	2,11	1,49	0,54	1,81	1,26	0,82	20
DOR80M2-02-2G	1,1	2,49	F	0,93	3,12	2,11	0,79	2,65	1,79	0,99	23
DOR90S-02-2G	1,5	3,32	F	1,27	4,2	2,82	1,08	3,63	2,39	1,3	29
DOR90L-02-2G	2,2	4,7	F	1,87	6,2	3,99	1,58	5,3	3,38	1,5	33
DOR100L-02-2G	3	6,1	F	2,55	8,5	5,1	2,16	7,2	4,3	3,1	42
DOR112M-02-2G	4	8	F	3,4	11,3	6,8	2,88	9,6	5,7	6	53
DOR132S1-02-2G	5,5	11,1	F	4,6	15,1	9,4	3,96	13	7,9	11,9	66
DOR132S2-02-2G	7,5	14,6	F	6,3	20,7	12,4	5,4	17,7	10,5	13,8	72
DOR160M1-02-2G	11	20,9	F	9,3	30,3	17,7	7,9	25,7	15	41,4	123
DOR160M2-02-2G	15	28,2	F	12,7	41,3	23,9	10,8	35,2	20,3	49,3	132
DOR160L-02-2G	18,5	34,6	F	15,7	51,1	29,4	13,3	43,3	24,9	60,5	151
DOR180M-02-2G	22	41,4	F	18,7	60,7	35,1	15,8	51,3	29,8	82,5	203
DOR200L1-02-2G	30	56,1	F	25,5	82,5	47,6	21,6	69,9	40,3	136	246
DOR200L2-02-2G	37	68,1	F	31,4	101	57,8	26,6	86,1	49	152	256
DOR225M-02-2G	45	82,4	F	38,2	123	70,0	32,4	104	59,3	256	328
DOR250M-02-2G	55	99,3	F	46,7	150	84,4	39,6	127	71,4	343	433
DOR280S-02-2G	75	134	F	63,7	205	113	54	174	96,4	683	565
DOR280M-02-2G	90	159	F	76,5	246	135	64,8	209	114	765	645
DOR315S-02-2G	110	196	F	93,5	300	166	79,2	254	141	1558	930
DOR315M-02-2G	132	234	F	112	359	198	95	304	168	1726	980
DOR315L1-02-2G	160	287	F	136	436	243	115	369	206	1941	1090
DOR315L2-02-2G	200	358	F	170	545	304	144	462	257	2212	1190
DOR355M-02-2G	250	433	F	212	679	368	180	576	311	3300	1775
DOR355L-02-2G	315	546	F	267	855	464	226	724	393	3950	1875

Type	Frame size	Ratings for mains operation										For direct-on-line starting		
		Rated power	Rated speed	Rated torque	Efficiency class acc. to EN 60034-30	Efficiency EN60034-2-1 : 2007			Power factor	Rated current at		Starting current	Starting torque	Break-down torque
		P <sub>N</sub> [kW]	n <sub>N</sub> [min <sup>-1</sup> ]	T <sub>N</sub> [Nm]		η [%]				cos φ	I <sub>N</sub> [A]			
					100%	75%	50%		400V	380... 420V	I <sub>s</sub> /I <sub>N</sub>	T <sub>s</sub> /T <sub>N</sub>	T <sub>B</sub> /T <sub>N</sub>	

Helmke DOR – cast iron motors

**IE2**

1500 min-1 (4-pole)

DOR63M1-04-1G	63	0,12	1310	0,87		57,0	56,8	53,0	0,72	0,42	0,44	4,4	2,1	2,2
DOR63M2-04-1G	63	0,18	1310	1,31		60,0	59,8	56,1	0,73	0,59	0,62	4,4	2,1	2,2
DOR71M1-04-1G	71	0,25	1330	1,79		65,0	64,8	61,2	0,74	0,75	0,78	5,2	2,1	2,2
DOR71M2-04-1G	71	0,37	1330	2,65		67,0	66,8	63,3	0,75	1,06	1,11	5,2	2,1	2,2
DOR80M1-04-1G	80	0,55	1390	3,77		71,1	70,9	67,7	0,74	1,5	1,58	5,7	2,4	2,3
DOR80M2-04-2G	80	0,75	1400	5,1	<b>IE2</b>	79,6	79,4	76,9	0,76	1,78	1,87	6,5	2,3	2,3
DOR90S-04-2G	90	1,1	1430	7,3	<b>IE2</b>	81,4	81,2	78,8	0,77	2,53	2,65	6,5	2,3	2,3
DOR90L-04-2G	90	1,5	1430	10	<b>IE2</b>	82,8	82,7	80,4	0,77	3,39	3,56	6,5	2,3	2,3
DOR100L1-04-2G	100	2,2	1430	14,6	<b>IE2</b>	84,3	84,2	82,0	0,81	4,6	4,8	7,5	2,3	2,3
DOR100L2-04-2G	100	3	1430	20	<b>IE2</b>	85,5	85,4	83,4	0,82	6,1	6,4	7,5	2,3	2,3
DOR112M-04-2G	112	4	1435	26,6	<b>IE2</b>	86,6	86,5	84,6	0,82	8,1	8,5	7,5	2,3	2,3
DOR132S-04-2G	132	5,5	1440	36,4	<b>IE2</b>	87,7	87,6	85,9	0,83	10,9	11,4	7,5	2,3	2,3
DOR132M-04-2G	132	7,5	1440	49,7	<b>IE2</b>	88,7	88,6	87,0	0,84	14,5	15,2	7,5	2,3	2,3
DOR160M-04-2G	160	11	1460	71,9	<b>IE2</b>	89,8	89,7	88,2	0,84	21,0	22,1	8,9	2,2	2,3
DOR160L-04-2G	160	15	1460	98,1	<b>IE2</b>	90,6	90,5	89,1	0,85	28,1	29,5	8,9	2,2	2,3
DOR180M-04-2G	180	18,5	1470	120	<b>IE2</b>	91,2	91,1	89,8	0,86	34,0	35,7	7,9	2,2	2,3
DOR180L-04-2G	180	22	1470	142	<b>IE2</b>	91,6	91,5	90,3	0,86	40,3	42,3	7,9	2,2	2,3
DOR200L-04-2G	200	30	1470	194	<b>IE2</b>	92,3	92,2	91,1	0,86	54,5	57,2	7,9	2,2	2,3
DOR225S-04-2G	225	37	1475	239	<b>IE2</b>	92,7	92,6	91,5	0,87	66,2	69,5	7,9	2,2	2,3
DOR225M-04-2G	225	45	1470	292	<b>IE2</b>	93,1	93,0	92,0	0,87	80,1	84,2	7,9	2,2	2,3
DOR250M-04-2G	250	55	1480	354	<b>IE2</b>	93,5	93,4	92,4	0,87	97,5	102	7,9	2,2	2,3
DOR280S-04-2G	280	75	1475	485	<b>IE2</b>	94,0	93,9	93,0	0,87	132	138	7,2	2,2	2,5
DOR280M-04-2G	280	90	1475	582	<b>IE2</b>	94,2	94,1	93,3	0,87	158	166	7,2	2,2	2,5
DOR315S-04-2G	315	110	1485	707	<b>IE2</b>	94,5	94,4	93,6	0,86	195	205	7,5	2,1	3,0
DOR315M-04-2G	315	132	1485	848	<b>IE2</b>	94,7	94,6	93,8	0,86	233	245	7,5	2,1	3,0
DOR315L1-04-2G	315	160	1485	1028	<b>IE2</b>	94,9	94,9	94,1	0,86	282	297	7,8	2,1	3,0
DOR315L2-04-2G	315	200	1485	1286	<b>IE2</b>	95,1	95,1	94,3	0,85	357	374	7,8	2,1	3,0
DOR355M-04-2G	355	250	1485	1607	<b>IE2</b>	95,1	95,1	94,3	0,90	421	442	7,9	2,1	2,2
DOR355L-04-2G	355	315	1485	2025	<b>IE2</b>	95,1	95,1	94,3	0,89	537	564	7,9	2,1	2,2

Type	Ratings for operation with IGBT converter									Inertia J [10 <sup>-3</sup> kgm <sup>2</sup> ]	Weight [kg]
	T ~ n <sup>2</sup> , self-ventilated or T = constant, forced-ventilated			T = constant, self-ventilated			T = constant, self-ventilated				
	Speed range 5...50 Hz			Speed range 17...50 Hz			Speed range 5...50 Hz				
P at 50 Hz [kW]	I [A]	Temp. class	P at 50 Hz [kW]	T [Nm]	I [A]	P at 50 Hz [kW]	T [Nm]	I [A]	J	Weight	

Helmke DOR – cast iron motors

**IE2**

1500 min<sup>-1</sup> (4-pole)

DOR63M1-04-1G	0,12	0,44	F	0,09	0,65	0,33	0,07	0,51	0,27	0,27	13
DOR63M2-04-1G	0,18	0,62	F	0,13	0,94	0,47	0,11	0,8	0,38	0,32	14
DOR71M1-04-1G	0,25	0,78	F	0,19	1,36	0,59	0,15	1,07	0,48	0,45	15
DOR71M2-04-1G	0,37	1,11	F	0,28	2,01	0,84	0,23	1,65	0,69	0,51	16
DOR80M1-04-1G	0,55	1,58	F	0,41	2,81	1,2	0,34	2,33	0,98	1,8	17
DOR80M2-04-2G	0,75	1,87	F	0,57	3,88	1,42	0,46	3,13	1,16	2,3	22
DOR90S-04-2G	1,1	2,65	F	0,83	5,5	2,01	0,68	4,5	1,65	2,3	29
DOR90L-04-2G	1,5	3,56	F	1,14	7,6	2,7	0,93	6,2	2,22	2,9	44
DOR100L1-04-2G	2,2	4,8	F	1,67	11,1	3,64	1,37	9,1	3	5,9	44
DOR100L2-04-2G	3	6,4	F	2,28	15,2	4,8	1,87	12,4	4	7,3	46
DOR112M-04-2G	4	8,5	F	3,04	20,2	6,4	2,5	16,6	5,3	10,4	57
DOR132S-04-2G	5,5	11,4	F	4,1	27,1	8,6	3,43	22,7	7,1	23,5	68
DOR132M-04-2G	7,5	15,2	F	5,7	37,8	11,5	4,6	30,5	9,5	32,5	80
DOR160M-04-2G	11	22,1	F	8,3	54,2	16,7	6,8	44,4	13,8	82,1	123
DOR160L-04-2G	15	29,5	F	11,4	74,5	22,4	9,3	60,8	18,4	100	153
DOR180M-04-2G	18,5	35,7	F	14	90,9	27,1	11,5	74,7	22,3	152	204
DOR180L-04-2G	22	42,3	F	16,7	108	32,1	13,7	89	26,4	173	215
DOR200L-04-2G	30	57,2	F	22,8	148	43,4	18,7	121	35,7	288	243
DOR225S-04-2G	37	69,5	F	28,1	181	52,8	23,1	149	43,4	446	305
DOR225M-04-2G	45	84,2	F	34,2	222	63,9	28,1	182	52,6	515	328
DOR250M-04-2G	55	102	F	41,8	269	77,5	34,3	221	63,7	726	452
DOR280S-04-2G	75	138	F	57	369	104	46,8	303	86,2	1552	620
DOR280M-04-2G	90	166	F	68,4	442	126	56,2	363	103	1865	695
DOR315S-04-2G	110	205	F	83,6	537	155	68,7	441	128	3480	931
DOR315M-04-2G	132	245	F	100	643	186	82,5	530	153	3678	1017
DOR315L1-04-2G	160	297	F	121	778	225	100	643	185	4482	1085
DOR315L2-04-2G	200	374	F	152	977	284	125	803	233	4856	1200
DOR355M-04-2G	250	442	F	190	1221	335	156	1003	276	7300	1850
DOR355L-04-2G	315	564	F	239	1537	428	196	1260	352	8800	2050

Type	Frame size	Ratings for mains operation									For direct-on-line starting			
		Rated power	Rated speed	Rated torque	Efficiency class acc. to EN 60034-30	Efficiency EN60034-2-1 : 2007			Power factor $\cos \varphi$	Rated current at		Starting current $I_s/I_N$	Starting torque $T_s/T_N$	Break-down torque $T_B/T_N$
		$P_N$ [kW]	$n_N$ [min <sup>-1</sup> ]	$T_N$ [Nm]		$\eta$ [%]				$I_N$ [A]				
						100%	75%	50%		400V	380... 420V			

Helmke DOR – cast iron motors

**IE2**

1000 min<sup>-1</sup> (6-pole)

DOR71M1-06-1G	71	0,18	850	2,02		56,0	55,8	52,0	0,66	0,7	0,73	4,0	1,9	2,0
DOR71M2-06-1G	71	0,25	850	2,8		59,0	58,8	55,1	0,68	0,89	0,94	4,0	1,9	2,0
DOR80M1-06-1G	80	0,37	885	3,99		62,0	61,8	58,1	0,70	1,23	1,29	4,7	1,9	2,0
DOR80M2-06-1G	80	0,55	885	5,9		65,1	64,9	61,4	0,72	1,69	1,77	4,7	1,9	2,1
DOR90S-06-2G	90	0,75	910	7,8	<b>IE2</b>	75,9	75,7	72,8	0,69	2,06	2,17	5,9	2,0	2,1
DOR90L-06-2G	90	1,1	910	11,5	<b>IE2</b>	78,1	77,9	75,2	0,69	2,94	3,09	5,9	2,0	2,1
DOR100L-06-2G	100	1,5	930	15,4	<b>IE2</b>	79,8	79,6	77,1	0,75	3,61	3,79	5,9	2,0	2,1
DOR112M-06-2G	112	2,2	940	22,3	<b>IE2</b>	81,8	81,7	79,3	0,76	5,1	5,3	6,9	2,0	2,1
DOR132S-06-2G	132	3	960	29,8	<b>IE2</b>	83,3	83,2	80,9	0,76	6,8	7,1	6,9	2,1	2,1
DOR132M1-06-2G	132	4	960	39,7	<b>IE2</b>	84,6	84,5	82,4	0,76	8,9	9,4	6,9	2,1	2,1
DOR132M2-06-2G	132	5,5	960	54,7	<b>IE2</b>	86,0	85,9	83,9	0,77	11,9	12,5	6,9	2,1	2,1
DOR160M-06-2G	160	7,5	970	73,8	<b>IE2</b>	87,2	87,1	85,3	0,77	16,1	16,9	6,0	2,0	2,1
DOR160L-06-2G	160	11	970	108	<b>IE2</b>	88,7	88,6	87,0	0,78	22,9	24,0	6,0	2,0	2,1
DOR180L-06-2G	180	15	970	147	<b>IE2</b>	89,7	89,6	88,1	0,81	29,7	31,2	7,5	2,0	2,1
DOR200L1-06-2G	200	18,5	970	182	<b>IE2</b>	90,4	90,3	88,9	0,81	36,4	38,2	7,5	2,1	2,1
DOR200L2-06-2G	200	22	970	216	<b>IE2</b>	90,9	90,8	89,5	0,83	42,0	44,1	7,5	2,1	2,1
DOR225M-06-2G	225	30	980	292	<b>IE2</b>	91,7	91,6	90,4	0,84	56,2	59,0	7,5	2,0	2,1
DOR250M-06-2G	250	37	980	360	<b>IE2</b>	92,2	92,1	91,0	0,86	67,3	70,7	7,5	2,1	2,1
DOR280S-06-2G	280	45	980	438	<b>IE2</b>	92,7	92,6	91,5	0,86	81,4	85,5	7,0	2,1	2,5
DOR280M-06-2G	280	55	980	535	<b>IE2</b>	93,1	93,0	92,0	0,86	99,1	104	7,0	2,1	2,5
DOR315S-06-2G	315	75	985	727	<b>IE2</b>	93,7	93,6	92,7	0,85	135	142	8,0	2,0	2,2
DOR315M-06-2G	315	90	985	872	<b>IE2</b>	94,0	93,9	93,0	0,85	162	170	8,0	2,0	2,2
DOR315L1-06-2G	315	110	985	1066	<b>IE2</b>	94,3	94,2	93,4	0,86	195	205	8,0	2,0	2,2
DOR315L2-06-2G	315	132	985	1279	<b>IE2</b>	94,6	94,5	93,7	0,86	234	245	8,0	2,0	2,2
DOR355M1-06-2G	355	160	990	1543	<b>IE2</b>	94,8	94,8	93,9	0,88	276	290	7,6	2,0	2,0
DOR355M2-06-2G	355	200	990	1929	<b>IE2</b>	95,0	95,0	94,2	0,88	345	362	7,6	2,0	2,0
DOR355L-06-2G	355	250	990	2411	<b>IE2</b>	95,0	95,0	94,2	0,88	431	453	7,6	2,0	2,0

Type	Ratings for operation with IGBT converter									Inertia J [10 <sup>-3</sup> kgm <sup>2</sup> ]	Weight [kg]
	T ~ n <sup>2</sup> , self-ventilated or T = constant, forced-ventilated			T = constant, self-ventilated			T = constant, self-ventilated				
	Speed range 5...50 Hz			Speed range 17...50 Hz			Speed range 5...50 Hz				
P at 50 Hz [kW]	I [A]	Temp. class	P at 50 Hz [kW]	T [Nm]	I [A]	P at 50 Hz [kW]	T [Nm]	I [A]	J	Weight	

Helmke DOR – cast iron motors

**IE2**

1000 min<sup>-1</sup> (6-pole)

DOR71M1-06-1G	0,18	0,73	F	0,13	1,46	0,55	0,11	1,23	0,45	0,65	9,5
DOR71M2-06-1G	0,25	0,94	F	0,19	2,13	0,71	0,15	1,68	0,58	0,74	11
DOR80M1-06-1G	0,37	1,29	F	0,28	3,02	0,98	0,23	2,48	0,8	1,5	17
DOR80M2-06-1G	0,55	1,77	F	0,41	4,4	1,34	0,34	3,66	1,1	2,1	19
DOR90S-06-2G	0,75	2,17	F	0,57	5,9	1,64	0,46	4,8	1,35	3,1	27
DOR90L-06-2G	1,1	3,09	F	0,83	8,7	2,34	0,68	7,1	1,93	3,8	30
DOR100L-06-2G	1,5	3,79	F	1,14	11,7	2,88	0,93	9,5	2,36	7,5	39
DOR112M-06-2G	2,2	5,3	F	1,67	16,9	4,0	1,37	13,9	3,31	15,1	54
DOR132S-06-2G	3	7,1	F	2,28	22,6	5,3	1,87	18,6	4,4	31,4	70
DOR132M1-06-2G	4	9,4	F	3,04	30,2	7,1	2,5	24,8	5,8	39,2	80
DOR132M2-06-2G	5,5	12,5	F	4,1	40,7	9,5	3,43	34,1	7,8	49,3	92
DOR160M-06-2G	7,5	16,9	F	5,7	56,1	12,8	4,6	45,2	10,5	96,9	123
DOR160L-06-2G	11	24	F	8,3	81,7	18,2	6,8	66,9	15	127	157
DOR180L-06-2G	15	31,2	F	11,4	112	23,7	9,3	91,5	19,5	227	206
DOR200L1-06-2G	18,5	38,2	F	14	137	29	11,5	113	23,8	346	243
DOR200L2-06-2G	22	44,1	F	16,7	164	33,5	13,7	134	27,5	396	256
DOR225M-06-2G	30	59	F	22,8	222	44,8	18,7	182	36,8	601	306
DOR250M-06-2G	37	70,7	F	28,1	273	53,7	23,1	225	44,1	917	416
DOR280S-06-2G	45	85,5	F	34,2	333	64,9	28,1	273	53,4	1732	555
DOR280M-06-2G	55	104	F	41,8	407	79	34,3	334	65	1965	640
DOR315S-06-2G	75	142	F	57	552	107	46,8	453	88,7	3723	866
DOR315M-06-2G	90	170	F	68,4	663	129	56,2	544	106	4526	948
DOR315L1-06-2G	110	205	F	83,6	810	155	68,7	666	128	5157	1120
DOR315L2-06-2G	132	245	F	100	969	186	82,5	799	153	5685	1185
DOR355M1-06-2G	160	290	F	121	1167	220	100	964	181	9320	1770
DOR355M2-06-2G	200	362	F	152	1466	275	125	1205	226	10800	1900
DOR355L-06-2G	250	453	F	190	1832	344	156	1504	283	12900	2150

Type	Frame size	Ratings for mains operation										For direct-on-line starting		
		Rated power	Rated speed	Rated torque	Efficiency class acc. to EN 60034-30	Efficiency EN60034-2-1 : 2007			Power factor	Rated current at		Starting current	Starting torque	Break-down torque
		P <sub>N</sub> [kW]	n <sub>N</sub> [min <sup>-1</sup> ]	T <sub>N</sub> [Nm]		η [%]			cos φ	I <sub>N</sub> [A]				
					100%	75%	50%		400V	380... 420V	I <sub>s</sub> /I <sub>N</sub>	T <sub>s</sub> /T <sub>N</sub>	T <sub>B</sub> /T <sub>N</sub>	

### Helmke DOR – cast iron motors

#### 750 min<sup>-1</sup> (8-pole)

DOR80M1-08-1G	80	0,18	645	2,66		51,0	50,8	47,0	0,61	0,83	0,87	3,3	1,8	1,9
DOR80M2-08-1G	80	0,25	645	3,7		54,0	53,8	50,0	0,60	1,11	1,16	3,3	1,8	1,9
DOR90S-08-1G	90	0,37	670	5,2		62,0	61,8	58,1	0,61	1,41	1,48	4,0	1,8	1,9
DOR90L-08-1G	90	0,55	670	7,8		63,0	62,8	59,2	0,61	2,06	2,16	4,0	1,8	2,0
DOR100L1-08-1G	100	0,75	680	10,5		71,0	70,8	67,6	0,67	2,27	2,38	4,0	1,8	2,0
DOR100L2-08-1G	100	1,1	680	15,4		73,0	72,8	69,7	0,69	3,15	3,3	5,0	1,8	2,0
DOR112M-08-1G	112	1,5	690	20,7		75,0	74,8	71,9	0,69	4,1	4,3	5,0	1,8	2,0
DOR132S-08-1G	132	2,2	705	29,8		78,0	77,8	75,1	0,71	5,7	6,0	6,0	1,8	2,0
DOR132M-08-1G	132	3	705	40,6		79,0	78,8	76,2	0,73	7,5	7,8	6,0	1,8	2,0
DOR160M1-08-1G	160	4	720	53		81,0	80,8	78,4	0,73	9,7	10,2	6,0	1,9	2,0
DOR160M2-08-1G	160	5,5	720	72,9		83,0	82,9	80,6	0,74	12,9	13,5	6,0	2,0	2,0
DOR160L-08-1G	160	7,5	720	99,4		85,5	85,4	83,4	0,75	16,8	17,7	6,0	2,0	2,0
DOR180L-08-1G	180	11	725	144		87,5	87,4	85,6	0,76	23,8	25,0	6,6	2,0	2,0
DOR200L-08-1G	200	15	730	196		88,0	87,9	86,2	0,76	32,3	33,9	6,6	1,9	2,0
DOR225S-08-1G	225	18,5	730	242		90,0	89,9	88,5	0,76	39,0	40,9	6,6	1,9	2,0
DOR225M-08-1G	225	22	730	287		90,5	90,4	89,0	0,77	45,5	47,8	6,6	1,9	2,0
DOR250M-08-1G	250	30	730	392		91,0	90,9	89,6	0,79	60,2	63,2	6,6	1,9	2,0
DOR280S-08-1G	280	37	735	480		91,5	91,4	90,2	0,79	73,8	77,5	5,6	2,1	2,6
DOR280M-08-1G	280	45	735	584		92,0	91,9	90,7	0,79	89,3	93,8	5,8	2,1	2,7
DOR315S-08-1G	315	55	735	714		92,8	92,7	91,6	0,80	106	112	5,1	1,7	2,6
DOR315M-08-1G	315	75	735	974		93,0	92,9	91,9	0,81	143	150	6,1	2,0	2,7
DOR315L1-08-1G	315	90	735	1169		93,5	93,4	92,4	0,82	169	177	6,2	2,1	2,7
DOR315L2-08-1G	315	110	735	1429		93,7	93,6	92,7	0,82	206	216	5,9	2,0	2,6
DOR355M1-08-1G	355	132	740	1703		93,7	93,6	92,7	0,82	247	260	6,6	1,8	2,0
DOR355M2-08-1G	355	160	740	2064		94,0	93,9	93,0	0,82	299	314	6,6	1,8	2,0
DOR355L-08-1G	355	200	740	2581		94,0	93,9	93,0	0,83	370	388	6,6	1,8	2,0

Type	Ratings for operation with IGBT converter									Inertia J [10 <sup>-3</sup> kgm <sup>2</sup> ]	Weight [kg]
	T ~ n <sup>2</sup> , self-ventilated or T = constant, forced-ventilated Speed range 5...50 Hz			T = constant, self-ventilated Speed range 17...50 Hz			T = constant, self-ventilated Speed range 5...50 Hz				
	P at 50 Hz [kW]	I [A]	Temp. class	P at 50 Hz [kW]	T [Nm]	I [A]	P at 50 Hz [kW]	T [Nm]	I [A]		

### Helmke DOR – cast iron motors

#### 750 min<sup>-1</sup> (8-pole)

DOR80M1-08-1G	0,18	0,87	F	0,13	1,92	0,66	0,11	1,62	0,54	1,5	17
DOR80M2-08-1G	0,25	1,16	F	0,19	2,81	0,88	0,15	2,22	0,72	2,1	19
DOR90S-08-1G	0,37	1,48	F	0,28	3,99	1,12	0,23	3,27	0,92	2,9	23
DOR90L-08-1G	0,55	2,16	F	0,41	5,8	1,64	0,34	4,8	1,35	3,5	25
DOR100L1-08-1G	0,75	2,38	F	0,57	8,0	1,8	0,46	6,4	1,48	6,9	33
DOR100L2-08-1G	1,1	3,3	F	0,83	11,6	2,5	0,68	9,5	2,06	10,7	38
DOR112M-08-1G	1,5	4,3	F	1,14	15,7	3,26	0,93	12,8	2,68	14,9	50
DOR132S-08-1G	2,2	6	F	1,67	22,6	4,5	1,37	18,5	3,75	31,4	63
DOR132M-08-1G	3	7,8	F	2,28	30,8	5,9	1,87	25,3	4,8	39,5	79
DOR160M1-08-1G	4	10,2	F	3,04	40,3	7,7	2,5	33,1	6,3	75,3	118
DOR160M2-08-1G	5,5	13,5	F	4,1	54,3	10,2	3,43	45,4	8,4	93,1	119
DOR160L-08-1G	7,5	17,7	F	5,7	75,6	13,4	4,6	61	11,0	126	145
DOR180L-08-1G	11	25	F	8,3	109	19,0	6,8	89,5	15,6	203	184
DOR200L-08-1G	15	33,9	F	11,4	149	25,7	9,3	121	21,1	339	250
DOR225S-08-1G	18,5	40,9	F	14	183	31,0	11,5	150	25,5	491	266
DOR225M-08-1G	22	47,8	F	16,7	218	36,3	13,7	179	29,8	547	292
DOR250M-08-1G	30	63,2	F	22,8	298	48	18,7	244	39,5	834	405
DOR280S-08-1G	37	77,5	F	28,1	365	58,9	23,1	300	48,4	1547	475
DOR280M-08-1G	45	93,8	F	34,2	444	71,2	28,1	365	58,6	1857	555
DOR315S-08-1G	55	112	F	41,8	543	85,1	34,3	445	70,0	3682	905
DOR315M-08-1G	75	150	F	57	740	114	46,8	608	93,7	4959	981
DOR315L1-08-1G	90	177	F	68,4	888	134	56,2	730	110	5825	1071
DOR315L2-08-1G	110	216	F	83,6	1086	164	68,7	892	135	6753	1160
DOR355M1-08-1G	132	260	F	100	1290	197	82,5	1064	162	12900	1800
DOR355M2-08-1G	160	314	F	121	1561	238	100	1290	196	14300	1890
DOR355L-08-1G	200	388	F	152	1961	294	125	1613	242	15900	2040

## Dimensions cast iron motors in frame size 63...180 IE2

Mounting arrangement IM 1001 (B3)

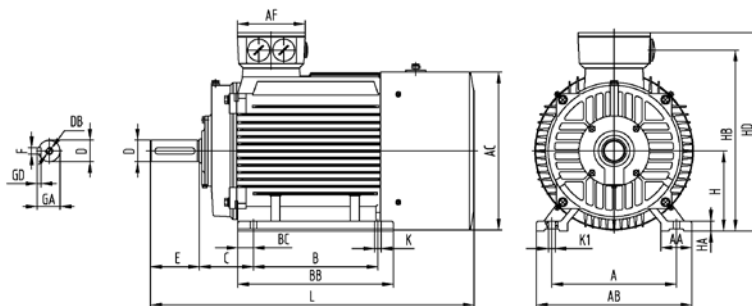

Type	Frame size	No. of poles	Dimensions according to IEC [mm]													
			H	A	B	C	AB	BB	BC	HD	AC	HB	HA	K	K1	L
			Dimensions according to DIN [mm]													
<b>IE2</b>			h	b	a	w1	f	e		m1	g	v	c	s		k
DOR63M1, M2	63	2...4	63	100	80	40	130	110	15	180	120	155	8	7	7	220
DOR71M1, M2	71	2...4	71	112	90	45	144	120	15	195	136	168	8	7	7	255
DOR80M1, M2	80	2...6	80	125	100	50	160	130	15	213	156	187	10	10	10	295
DOR90S	90S	2...8	90	140	100	56	174	140	20	250	176	217	12	10	10	315
DOR90L	90L	2...8	90	140	125	56	174	165	20	250	176	217	12	10	10	340
DOR100L, L1, L2	100L	2...8	100	160	140	63	200	253	18	270	198	238	14	12	12	457
DOR112M	112M	2...8	112	190	140	70	230	180	20	296	220	270	15	12	12	400
DOR132S, S1, S2	132S	2...8	132	216	140	89	270	186	23	335	258	301	20	12	12	470
DOR132M, M1, M2	132M	2...8	132	216	178	89	270	224	23	335	258	301	20	12	12	510
DOR160M, M1, M2	160M	2...8	160	254	210	108	320	260	25	420	314	382	20	15	15	615
DOR160L	160L	2...8	160	254	254	108	320	304	25	420	314	382	20	15	15	670
DOR180M	180M	2...8	180	279	241	121	355	349	35	460	355	410	22	15	15	738
DOR180L	180L	2...8	180	279	279	121	355	349	35	460	355	410	22	15	15	740

Type	Frame size	No. of poles	Dimensions according to IEC [mm]								
			AF	AA	D	E	F	GD	GA	DB	
			Dimensions according to DIN [mm]								
<b>IE2</b>			n	d	l	u		t	d6/d7		
DOR63M1, M2	63	2...4	88	30	11	23	4	4	12.5	M4	
DOR71M1, M2	71	2...4	88	32	14	30	5	5	16	M5	
DOR80M1, M2	80	2...6	92	34	19	40	6	6	21.5	M6	
DOR90S	90S	2...8	100	36	24	50	8	7	27	M8	
DOR90L	90L	2...8	100	36	24	50	8	7	27	M8	
DOR100L, L1, L2	100L	2...8	100	40	28	60	8	7	31	M10	
DOR112M	112M	2...8	108	52	28	60	8	7	31	M10	
DOR132S, S1, S2	132S	2...8	108	59	38	80	10	8	41	M12	
DOR132M, M1, M2	132M	2...8	108	59	38	80	10	8	41	M12	
DOR160M, M1, M2	160M	2...8	160	65	42	110	12	8	45	M16	
DOR160L	160L	2...8	160	65	42	110	12	8	45	M16	
DOR180M	180M	2...8	160	73	48	110	14	9	51,5	M16	
DOR180L	180L	2...8	160	73	48	110	14	9	51,5	M16	



Mounting arrangement IM 2001 (B35), IM 3001 (B5) without feet

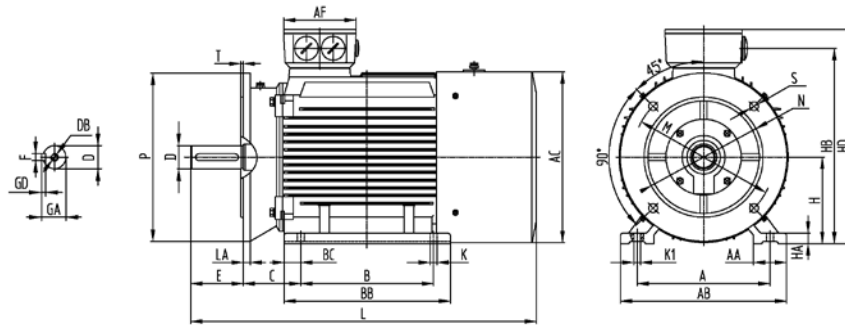

Mounting arrangement IM (B34), IM 3601 (B14) without feet

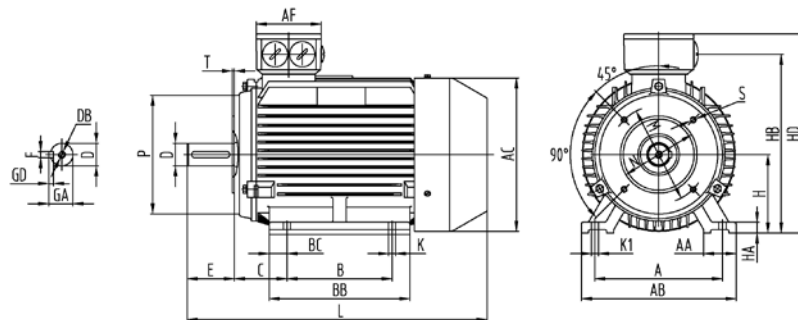

Type	Frame size	No. of poles	Flange B5						Small flange B14					Big flange B14				
			Dimensions according to IEC [mm]															
			M	N	P	T	LA	S <sup>1)</sup>	M	N	P	T	S	M	N	P	T	S
			Dimensions according to DIN [mm]															
<b>IE2</b>			e1	b1	a1	f1	c1	s1 <sup>1)</sup>	e1	b1	a1	f1	s1	e1	b1	a1	f1	s1
DOR63M1, M2	63	2...4	115	95	140	3	10	4 x M8	75	60	90	2,5	4 x M5	100	80	120	3	4 x M6
DOR71M1, M2	71	2...4	130	110	160	3,5	10	4 x M8	85	70	105	2,5	4 x M6	115	95	140	3	4 x M8
DOR80M1, M2	80	2...6	165	130	200	3,5	12	4 x M10	100	80	120	3	4 x M6	130	110	160	3,5	4 x M8
DOR90S	90S	2...8	165	130	200	3,5	12	4 x M10	115	95	140	3	4 x M8	130	110	160	3,5	4 x M8
DOR90L	90L	2...8	165	130	200	3,5	12	4 x M10	115	95	140	3	4 x M8	130	110	160	3,5	4 x M8
DOR100L, L1, L2	100L	2...8	215	180	250	4	13	4 x M12	130	110	160	3,5	4 x M8	165	130	200	3,5	4 x M10
DOR112M	112M	2...8	215	180	250	4	14	4 x M12	130	110	160	3,5	4 x M8	165	130	200	3,5	4 x M10
DOR132S, S1, S2	132S	2...8	265	230	300	4	14	4 x M12	165	130	200	3,5	4 x M10	215	180	250	4	4 x M12
DOR132M, M1, M2	132M	2...8	265	230	300	4	14	4 x M12	165	130	200	3,5	4 x M10	215	180	250	4	4 x M12
DOR160M, M1, M2	160M	2...8	300	250	350	5	15	4 x M16	-	-	-	-	-	-	-	-	-	-
DOR160L	160L	2...8	300	250	350	5	15	4 x M16	-	-	-	-	-	-	-	-	-	-
DOR180M	180M	2...8	300	250	350	5	15	4 x M16	-	-	-	-	-	-	-	-	-	-
DOR180L	180L	2...8	300	250	350	5	15	4 x M16	-	-	-	-	-	-	-	-	-	-

<sup>1)</sup> Through hole, suitable for screws

**Dimensions cast iron motors in frame size 200...355 IE2**

Mounting arrangement IM 1001 (B3)

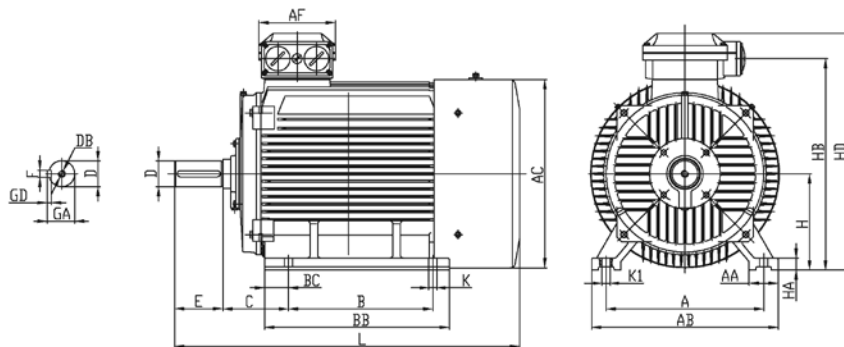

Type	Frame size	No. of poles	Dimensions according to IEC [mm]													
			H	A	B	C	AB	BB	BC	HD	AC	HB	HA	K	K1	L
			Dimensions according to DIN [mm]													
			h	b	a	w1	f	e		m1	g	v	c	s		k
DOR200L, L1, L2	200L	2...8	200	318	305	133	395	369	32	520	397	454	25	19	19	770
DOR225S	225S	4...8	225	356	286	149	435	375	40	560	445	500	28	19	19	820
DOR225M	225M	2	225	356	311	149	435	400	40	560	445	500	28	19	19	815
		4...8	225	356	311	149	435	400	40	560	445	500	28	19	19	845
DOR250M	250M	2	250	406	349	168	490	450	55	620	484	556	30	24	24	910
		4...8	250	406	349	168	490	450	55	620	484	556	30	24	24	910
DOR280S	280S	2	280	457	368	190	550	490	70	695	547	615	35	24	24	980
		4...8	280	457	368	190	550	490	70	695	547	615	35	24	24	1010
DOR280M	280M	2	280	457	419	190	550	540	70	695	547	615	35	24	24	1030
		4...8	280	457	419	190	550	540	70	695	547	615	35	24	24	1060
DOR315S	315S	2	315	508	406	216	630	570	84	861	620	758	45	28	28	1185
		4...8	315	508	406	216	630	570	84	861	620	758	45	28	28	1215
DOR315M	315M	2	315	508	457	216	630	680	84	861	620	758	45	28	28	1295
		4...8	315	508	457	216	630	680	84	861	620	758	45	28	28	1325
DOR315L1, L2	315L	2	315	508	508	216	630	680	84	861	620	758	45	28	28	1295
		4...8	315	508	508	216	630	680	84	861	620	758	45	28	28	1325
DOR355M, M1, M2	355M	2	355	610	560	254	730	750	68	990	710	877	52	28	28	1540
		4...8	355	610	560	254	730	750	68	990	710	877	52	28	28	1580
DOR355L	355L	2	355	610	630	254	730	750	70	985	710	860	54	28	28	1540
		4...8	355	610	630	254	730	750	68	990	710	877	52	28	28	1580

Mounting arrangement IM 1001 (B3)

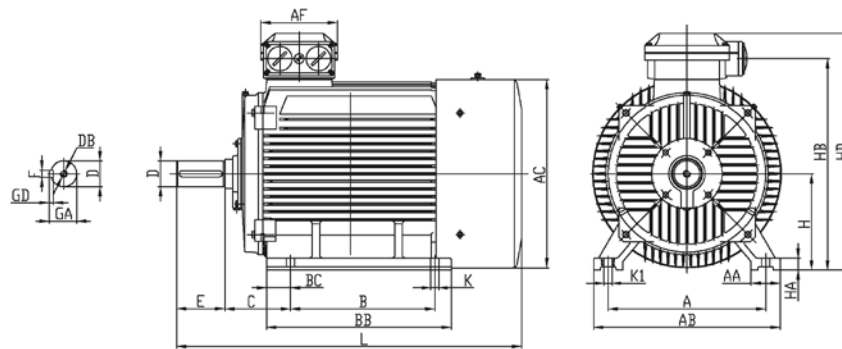

Type	Frame size	No. of poles	Dimensions according to IEC [mm]							
			AF	AA	D	E	F	GD	GA	DB
			Dimensions according to DIN [mm]							
<b>IE2</b>			n	d	l	u	t	d6/d7		
DOR200L, L1, L2	200L	2...8	196	70	55	110	16	10	59	M20
DOR225S	225S	4...8	196	83	60	140	18	11	64	M20
DOR225M	225M	2	196	83	55	110	16	10	59	M20
		4...8	196	83	60	140	18	11	64	M20
DOR250M	250M	2	222	88	60	140	18	11	64	M20
		4...8	222	88	65	140	18	11	69	M20
DOR280S	280S	2	222	85	65	140	18	11	69	M20
		4...8	222	85	75	140	20	12	79,5	M20
DOR280M	280M	2	222	85	65	140	18	11	69	M20
		4...8	222	85	75	140	20	12	79,5	M20
DOR315S	315S	2	288	120	65	140	18	11	69	M20
		4...8	288	120	80	170	22	14	85	M20
DOR315M	315M	2	288	120	65	140	18	11	69	M20
		4...8	288	120	80	170	22	14	85	M20
DOR315L1, L2	315L	2	288	120	65	140	18	11	69	M20
		4...8	288	120	80	170	22	14	85	M20
DOR355M, M1, M2	355M	2	350	116	75	140	20	12	79,5	M20
		4...8	350	116	100	210	28	16	106	M20
DOR355L	355L	2	350	118	75	140	32	14	85	M20
		4...8	350	116	100	210	28	16	106	M20

Mounting arrangement IM 2001 (B35), IM 3001 (B5) without feet

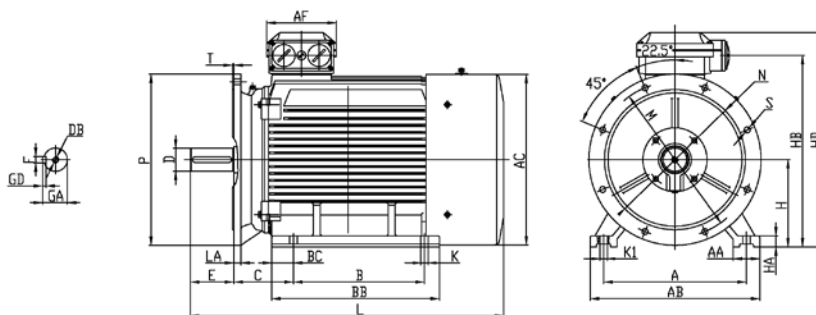

Type	Frame size	No. of poles	Flange B5					
			Dimensions according to IEC [mm]					
			M	N	P	T	LA	S <sup>1)</sup>
			Dimensions according to DIN [mm]					
<b>IE2</b>			e1	b1	a1	f1	c1	s1 <sup>1)</sup>
DOR200L, L1, L2	200L	2...8	350	300	400	5	17	4 x M16
DOR225S	225S	4...8	400	350	450	5	20	8 x M16
DOR225M	225M	2	400	350	450	5	20	8 x M16
		4...8	400	350	450	5	20	8 x M16
DOR250M	250M	2	500	450	550	5	22	8 x M16
		4...8	500	450	550	5	22	8 x M16
DOR280S	280S	2	500	450	550	5	22	8 x M16
		4...8	500	450	550	5	22	8 x M16
DOR280M	280M	2	500	450	550	5	22	8 x M16
		4...8	500	450	550	5	22	8 x M16
DOR315S	315S	2	600	550	660	6	22	8 x M20
		4...8	600	550	660	6	22	8 x M20
DOR315M	315M	2	600	550	660	6	22	8 x M20
		4...8	600	550	660	6	22	8 x M20
DOR315L1, L2	315L	2	600	550	660	6	22	8 x M20
		4...8	600	550	660	6	22	8 x M20
DOR355M, M1, M2	355M	2	740	680	800	6	25	8 x M20
		4...8	740	680	800	6	25	8 x M20
DOR355L	355L	2	740	680	800	6	25	8 x M20
		4...8	740	680	800	6	25	8 x M20

<sup>1)</sup> Through hole, suitable for screws



## Technical Data IE3

Type	Frame size	Ratings for mains operation								For direct-on-line starting				
		Rated power	Rated speed	Rated torque	Efficiency class acc. to EN 60034-30	Efficiency EN60034-2-1 : 2007			Power factor	Rated current at		Starting current	Starting torque	Break-down torque
		$P_N$ [kW]	$n_N$ [min <sup>-1</sup> ]	$T_N$ [Nm]		$\eta$ [%]	$\cos \varphi$	$I_N$ [A]		$I_s/I_N$	$T_s/T_N$			
						100%	75%	50%		400V	380... 420V			

Helmke DOR – cast iron motors

**IE3**

### 3000 min-1 (2-pole)

DOR80M1-02-3G	80	0,75	2848	2,51	<b>IE3</b>	80,7	80,5	78,1	0,75	1,78	1,87	7,3	3,1	3,2
DOR80M2-02-3G	80	1,1	2846	3,69	<b>IE3</b>	82,7	82,6	80,3	0,79	2,43	2,55	8,1	3,4	3,5
DOR90S-02-3G	90	1,5	2852	5	<b>IE3</b>	84,2	84,1	81,9	0,84	3,06	3,21	8,4	3,6	3,9
DOR90L-02-3G	90	2,2	2845	7,3	<b>IE3</b>	85,9	85,8	83,8	0,84	4,4	4,6	8,7	3,3	3,4
DOR100L-02-3G	100	3	2851	10	<b>IE3</b>	87,1	87	85,2	0,89	5,5	5,8	9,3	3,2	3,6
DOR112M-02-3G	112	4	2910	13,1	<b>IE3</b>	88,1	88	86,3	0,89	7,3	7,7	11	3,5	4
DOR132S1-02-3G	132	5,5	2905	18	<b>IE3</b>	89,2	89,1	87,5	0,89	9,9	10,4	9,9	3,2	4,1
DOR132S2-02-3G	132	7,5	2910	24,6	<b>IE3</b>	90,1	90	88,6	0,88	13,6	14,3	12	3,9	5,2
DOR160M1-02-3G	160	11	2958	35,5	<b>IE3</b>	91,2	91,1	89,8	0,88	19,7	20,7	7,5	2,2	2,3
DOR160M2-02-3G	160	15	2941	48,7	<b>IE3</b>	91,9	91,8	90,6	0,88	26,8	28,2	7,5	2,2	2,3
DOR160L-02-3G	160	18,5	2941	60	<b>IE3</b>	92,4	92,3	91,2	0,88	32,8	34,4	7,5	2,2	2,3
DOR180M-02-3G	180	22	2952	71,1	<b>IE3</b>	92,7	92,6	91,5	0,88	38,7	40,7	7,5	2	2,2
DOR200L1-02-3G	200	30	2960	96,7	<b>IE3</b>	93,3	93,2	92,2	0,86	53,9	56,6	7,5	2	2,3
DOR200L2-02-3G	200	37	2960	119	<b>IE3</b>	93,7	93,6	92,7	0,87	65,8	69,1	7,5	2	2,3
DOR225M-02-3G	225	45	2952	145	<b>IE3</b>	94	93,9	93	0,88	78,6	82,5	7,5	2	2,3
DOR250M-02-3G	250	55	2969	176	<b>IE3</b>	94,3	94,2	93,4	0,89	94,4	99,2	7,8	2	2,3
DOR280S-02-3G	280	75	2975	240	<b>IE3</b>	94,7	94,6	93,8	0,88	129	136	7,5	2	2,3
DOR280M-02-3G	280	90	2978	288	<b>IE3</b>	95	95	94,2	0,88	155	163	7,5	2	2,3
DOR315S-02-3G	315	110	2970	353	<b>IE3</b>	95,2	95,2	94,4	0,9	184	193	7,8	2,1	3,2
DOR315M-02-3G	315	132	2973	424	<b>IE3</b>	95,4	95,4	94,6	0,91	220	231	7,8	2,1	3,2
DOR315L1-02-3G	315	160	2970	514	<b>IE3</b>	95,6	95,6	94,9	0,9	269	282	8	2,1	3,2
DOR315L2-02-3G	315	200	2966	643	<b>IE3</b>	95,8	95,8	95,1	0,91	331	347	8	2,1	3,2
DOR355M-02-3G	355	250	2979	801	<b>IE3</b>	95,8	95,8	95,1	0,9	417	437	7,8	1,6	2

Type	Ratings for operation with IGBT converter									Inertia J [10 <sup>-3</sup> kgm <sup>2</sup> ]	Weight [kg]
	T ~ n <sup>2</sup> , self-ventilated or T = constant, forced-ventilated			T = constant, self-ventilated			T = constant, self-ventilated				
	Speed range 5...50 Hz			Speed range 17...50 Hz			Speed range 5...50 Hz				
P at 50 Hz [kW]	I [A]	Temp. class	P at 50 Hz [kW]	T [Nm]	I [A]	P at 50 Hz [kW]	T [Nm]	I [A]	J	Weight	

Helmke DOR – cast iron motors

**IE3**

3000 min<sup>-1</sup> (2-pole)

DOR80M1-02-3G	0,75	1,87	F	0,63	2,11	1,58	0,54	1,81	1,34	0,93	15
DOR80M2-02-3G	1,1	2,55	F	0,93	3,12	2,16	0,79	2,65	1,83	1,2	16
DOR90S-02-3G	1,5	3,21	F	1,27	4,2	2,72	1,08	3,61	2,31	2,2	21
DOR90L-02-3G	2,2	4,6	F	1,87	6,2	3,91	1,58	5,3	3,31	2,7	25
DOR100L-02-3G	3	5,8	F	2,55	8,5	4,9	2,16	7,2	4,1	4,9	35
DOR112M-02-3G	4	7,7	F	3,4	11,1	6,5	2,88	9,4	5,5	7,4	43
DOR132S1-02-3G	5,5	10,4	F	4,6	15,1	8,8	3,96	13	7,4	14,6	64
DOR132S2-02-3G	7,5	14,3	F	6,3	20,6	12,1	5,4	17,7	10,2	19	69
DOR160M1-02-3G	11	20,7	F	9,3	30	17,5	7,9	25,5	14,9	50,9	116
DOR160M2-02-3G	15	28,2	F	12,7	41,2	23,9	10,8	35	20,3	63,7	126
DOR160L-02-3G	18,5	34,4	F	15,7	50,9	29,2	13,3	43,1	24,7	76,4	145
DOR180M-02-3G	22	40,7	F	18,7	60,4	34,5	15,8	51,1	29,3	117	185
DOR200L1-02-3G	30	56,6	F	25,5	82,2	48,1	21,6	69,6	40,7	173	237
DOR200L2-02-3G	37	69,1	F	31,4	101	58,7	26,6	85,8	49,7	204	251
DOR225M-02-3G	45	82,5	F	38,2	123	70,1	32,4	104	59,4	301	320
DOR250M-02-3G	55	99,2	F	46,7	150	84,3	39,6	127	71,4	407	396
DOR280S-02-3G	75	136	F	63,7	204	115	54	173	97,9	798	550
DOR280M-02-3G	90	163	F	76,5	245	138	64,8	207	117	1070	580
DOR315S-02-3G	110	193	F	93,5	300	164	79,2	254	138	2031	970
DOR315M-02-3G	132	231	F	112	359	196	95	305	166	2206	1030
DOR315L1-02-3G	160	282	F	136	437	239	115	369	203	2486	1140
DOR315L2-02-3G	200	347	F	170	547	294	144	463	249	2906	1220
DOR355M-02-3G	250	437	F	212	679	371	180	577	314	3812	1780

Type	Frame size	Ratings for mains operation								For direct-on-line starting				
		Rated power	Rated speed	Rated torque	Efficiency class acc. to EN 60034-30	Efficiency EN60034-2-1 : 2007			Power factor	Rated current at		Starting current	Starting torque	Break-down torque
		P <sub>N</sub> [kW]	n <sub>N</sub> [min <sup>-1</sup> ]	T <sub>N</sub> [Nm]		η [%]				cos φ	I <sub>N</sub> [A]			
					100%	75%	50%		400V	380... 420V	I <sub>s</sub> /I <sub>N</sub>	T <sub>s</sub> /T <sub>N</sub>	T <sub>B</sub> /T <sub>N</sub>	

Helmke DOR – cast iron motors

**IE3**

1500 min-1 (4-pole)

DOR80M2-04-3G	80	0,75	1420	5	<b>IE3</b>	82,5	82,4	80	0,76	1,72	1,81	6,2	3,1	3,1
DOR90S-04-3G	90	1,1	1425	7,3	<b>IE3</b>	84,1	84	81,8	0,78	2,42	2,54	6,7	3,1	3,1
DOR90L-04-3G	90	1,5	1436	9,9	<b>IE3</b>	85,3	85,2	83,2	0,77	3,3	3,46	7,2	3,9	3,7
DOR100L1-04-3G	100	2,2	1430	14,6	<b>IE3</b>	86,7	86,6	84,7	0,82	4,4	4,6	8,5	3	3
DOR100L2-04-3G	100	3	1430	20	<b>IE3</b>	87,7	87,6	85,9	0,8	6,1	6,4	8,1	3,4	3,5
DOR112M-04-3G	112	4	1435	26,6	<b>IE3</b>	88,6	88,5	86,9	0,79	8,2	8,6	8,5	3,1	3,8
DOR132S-04-3G	132	5,5	1430	36,7	<b>IE3</b>	89,6	89,5	88	0,82	10,8	11,3	9	2,3	3,5
DOR132M-04-3G	132	7,5	1460	49	<b>IE3</b>	90,4	90,3	88,9	0,85	14,1	14,8	8,7	2,9	3,5
DOR160M-04-3G	160	11	1474	71,2	<b>IE3</b>	91,4	91,3	90	0,8	21,8	22,9	7	2,2	2,3
DOR160L-04-3G	160	15	1476	97	<b>IE3</b>	92,1	92	90,8	0,78	30,1	31,6	7,5	2,2	2,3
DOR180M-04-3G	180	18,5	1476	119	<b>IE3</b>	92,6	92,5	91,4	0,82	35,1	36,9	7,5	2,2	2,5
DOR180L-04-3G	180	22	1478	142	<b>IE3</b>	93	92,9	91,9	0,8	42,6	44,8	7,5	2,2	2,5
DOR200L-04-3G	200	30	1479	193	<b>IE3</b>	93,6	93,5	92,6	0,81	57,1	59,9	7,2	2,2	2,5
DOR225S-04-3G	225	37	1483	238	<b>IE3</b>	93,9	93,8	92,9	0,68	83,6	87,8	7,2	2,2	2,5
DOR225M-04-3G	225	45	1483	289	<b>IE3</b>	94,2	94,1	93,3	0,83	82,7	86,9	7,2	2,2	2,5
DOR250M-04-3G	250	55	1483	354	<b>IE3</b>	94,6	94,5	93,7	0,86	98	102	7,2	2,2	2,3
DOR280S-04-3G	280	75	1491	480	<b>IE3</b>	95	95	94,2	0,85	134	140	7,2	2,2	2,5
DOR280M-04-3G	280	90	1491	576	<b>IE3</b>	95,2	95,2	94,4	0,86	158	166	7,2	2,2	2,5
DOR315S-04-3G	315	110	1489	705	<b>IE3</b>	95,4	95,4	94,6	0,85	195	205	7,5	2,1	3
DOR315M-04-3G	315	132	1489	846	<b>IE3</b>	95,6	95,6	94,9	0,88	226	237	7,5	2,1	3
DOR315L1-04-3G	315	160	1489	1026	<b>IE3</b>	95,8	95,8	95,1	0,86	280	294	7,8	2,1	3
DOR315L2-04-3G	315	200	1487	1284	<b>IE3</b>	96	96	95,3	0,89	337	354	7,8	2,1	3
DOR355M-04-3G	355	250	1489	1603	<b>IE3</b>	96	96	95,3	0,89	423	444	7,9	2,1	2,2
DOR355L-04-3G	355	315	1487	2023	<b>IE3</b>	96	96	95,3	0,88	536	563	7,9	2,1	2,2



Type	Ratings for operation with IGBT converter									Inertia J [10 <sup>-3</sup> kgm <sup>2</sup> ]	Weight [kg]
	T ~ n <sup>2</sup> , self-ventilated or T = constant, forced-ventilated			T = constant, self-ventilated			T = constant, self-ventilated				
	Speed range 5...50 Hz			Speed range 17...50 Hz			Speed range 5...50 Hz				
P at 50 Hz [kW]	I [A]	Temp. class	P at 50 Hz [kW]	T [Nm]	I [A]	P at 50 Hz [kW]	T [Nm]	I [A]	J	Weight	

Helmke DOR – cast iron motors

**IE3**

1500 min<sup>-1</sup> (4-pole)

DOR80M2-04-3G	0,75	1,81	F	0,57	3,83	1,37	0,46	3,09	1,13	1,5	17
DOR90S-04-3G	1,1	2,54	F	0,83	5,5	1,93	0,68	4,5	1,58	3,7	23
DOR90L-04-3G	1,5	3,46	F	1,14	7,5	2,62	0,93	6,1	2,16	4,8	26
DOR100L1-04-3G	2,2	4,6	F	1,67	11,1	3,49	1,37	9,1	2,87	9,2	35
DOR100L2-04-3G	3	6,4	F	2,28	15,2	4,8	1,87	12,4	4	11,9	37
DOR112M-04-3G	4	8,6	F	3,04	20,2	6,5	2,5	16,6	5,3	15,4	48
DOR132S-04-3G	5,5	11,3	F	4,1	27,3	8,5	3,43	22,9	7	33,9	67
DOR132M-04-3G	7,5	14,8	F	5,7	37,2	11,2	4,6	30	9,2	35,1	86
DOR160M-04-3G	11	22,9	F	8,3	53,7	17,4	6,8	44	14,3	106	128
DOR160L-04-3G	15	31,6	F	11,4	73,7	24	9,3	60,1	19,7	128	149
DOR180M-04-3G	18,5	36,9	F	14	90,5	28	11,5	74,4	23	190	185
DOR180L-04-3G	22	44,8	F	16,7	107	34	13,7	88,5	28	226	200
DOR200L-04-3G	30	59,9	F	22,8	147	45,5	18,7	120	37,4	361	258
DOR225S-04-3G	37	87,8	F	28,1	180	66,7	23,1	148	54,8	629	314
DOR225M-04-3G	45	86,9	F	34,2	220	66	28,1	180	54,3	738	347
DOR250M-04-3G	55	102	F	41,8	269	77,5	34,3	220	63,7	1023	405
DOR280S-04-3G	75	140	F	57	365	106	46,8	299	87,5	2082	610
DOR280M-04-3G	90	166	F	68,4	438	126	56,2	359	103	2545	670
DOR315S-04-3G	110	205	F	83,6	536	155	68,7	440	128	3490	970
DOR315M-04-3G	132	237	F	100	641	180	82,5	529	148	4013	1060
DOR315L1-04-3G	160	294	F	121	776	223	100	641	183	5235	1160
DOR315L2-04-3G	200	354	F	152	976	269	125	802	221	5701	1270
DOR355M-04-3G	250	444	F	190	1218	337	156	1000	277	9297	1815
DOR355L-04-3G	315	563	F	239	1534	427	196	1258	351	10286	2000

Type	Frame size	Ratings for mains operation									For direct-on-line starting			
		Rated power	Rated speed	Rated torque	Efficiency class acc. to EN 60034-30	Efficiency EN60034-2-1 : 2007			Power factor	Rated current at		Starting current	Starting torque	Break-down torque
		P <sub>N</sub> [kW]	n <sub>N</sub> [min <sup>-1</sup> ]	T <sub>N</sub> [Nm]		η [%]				cos φ	I <sub>N</sub> [A]			
					100%	75%	50%		400V	380... 420V	I <sub>s</sub> /I <sub>N</sub>	T <sub>s</sub> /T <sub>N</sub>	T <sub>B</sub> /T <sub>N</sub>	

Helmke DOR – cast iron motors

**IE3**

1000 min<sup>-1</sup> (6-pole)

DOR90S-06-3G	90	0,75	935	7,6	<b>IE3</b>	78,9	78,7	76,1	0,76	1,8	1,89	4,4	2,1	2,5
DOR90L-06-3G	90	1,1	935	11,2	<b>IE3</b>	81	80,8	78,4	0,8	2,45	2,57	5,2	2,8	3
DOR100L-06-3G	100	1,5	940	15,2	<b>IE3</b>	82,5	82,4	80	0,82	3,2	3,36	5	2,1	2,6
DOR112M-06-3G	112	2,2	940	22,3	<b>IE3</b>	84,3	84,2	82	0,8	4,7	4,9	7,2	2,5	2,4
DOR132S-06-3G	132	3	940	30,4	<b>IE3</b>	85,6	85,5	83,5	0,83	6	6,3	6,8	2,5	2,4
DOR132M1-06-3G	132	4	945	40,4	<b>IE3</b>	86,8	86,7	84,8	0,84	7,9	8,3	7	2,7	2,8
DOR132M2-06-3G	132	5,5	845	62,1	<b>IE3</b>	88	87,9	86,2	0,82	11	11,5	7,1	2,6	2,7
DOR160M-06-3G	160	7,5	955	75	<b>IE3</b>	89,1	89	87,4	0,84	11,5	12,1	7,3	2,5	2,7
DOR160L-06-3G	160	11	974	107	<b>IE3</b>	90,3	90,2	88,8	0,73	24	25,2	6,5	2	2,3
DOR180L-06-3G	180	15	983	145	<b>IE3</b>	91,2	91,1	89,8	0,77	30,8	32,3	7	2	2,4
DOR200L1-06-3G	200	18,5	983	179	<b>IE3</b>	91,7	91,6	90,4	0,77	37,8	39,7	7	2,3	2,5
DOR200L2-06-3G	200	22	983	213	<b>IE3</b>	92,2	92,1	91	0,78	44,1	46,3	7	2,3	2,5
DOR225M-06-3G	225	30	985	290	<b>IE3</b>	92,9	92,8	91,8	0,82	56,8	59,6	7	2,4	2,6
DOR250M-06-3G	250	37	987	358	<b>IE3</b>	93,3	93,2	92,2	0,84	68,1	71,5	7	2,3	2,5
DOR280S-06-3G	280	45	990	434	<b>IE3</b>	93,7	93,6	92,7	0,84	82,5	86,6	7	2,3	2,5
DOR280M-06-3G	280	55	990	530	<b>IE3</b>	94,1	94	93,1	0,84	100	105	7	2,3	2,5
DOR315S-06-3G	315	75	991	722	<b>IE3</b>	94,6	94,5	93,7	0,83	137	144	7	2,2	2,4
DOR315M-06-3G	315	90	991	867	<b>IE3</b>	94,9	94,9	94,1	0,83	164	173	7	2,2	2,4
DOR315L1-06-3G	315	110	991	1060	<b>IE3</b>	95,1	95,1	94,3	0,84	198	208	6,8	2,2	2,4
DOR315L2-06-3G	315	132	992	1270	<b>IE3</b>	95,4	95,4	94,6	0,84	237	249	6,8	2,2	2,4
DOR355M1-06-3G	355	160	991	1541	<b>IE3</b>	95,6	95,6	94,9	0,85	285	299	6,8	2,1	2,3
DOR355M2-06-3G	355	200	991	1927	<b>IE3</b>	95,8	95,8	95,1	0,85	354	372	6,8	2,1	2,3
DOR355L-06-3G	355	250	990	2411	<b>IE3</b>	95,8	95,8	95,1	0,87	433	455	6,8	2,1	2,3

Type	Ratings for operation with IGBT converter									Inertia J [10 <sup>-3</sup> kgm <sup>2</sup> ]	Weight [kg]
	T ~ n <sup>2</sup> , self-ventilated or T = constant, forced-ventilated			T = constant, self-ventilated			T = constant, self-ventilated				
	Speed range 5...50 Hz			Speed range 17...50 Hz			Speed range 5...50 Hz				
P at 50 Hz [kW]	I [A]	Temp. class	P at 50 Hz [kW]	T [Nm]	I [A]	P at 50 Hz [kW]	T [Nm]	I [A]	J	Weight	

Helmke DOR – cast iron motors

**IE3**

1000 min<sup>-1</sup> (6-pole)

DOR90S-06-3G	0,75	1,89	F	0,57	5,8	1,43	0,46	4,6	1,18	4,3	26
DOR90L-06-3G	1,1	2,57	F	0,83	8,4	1,95	0,68	6,9	1,6	6,1	28
DOR100L-06-3G	1,5	3,36	F	1,14	11,5	2,55	0,93	9,4	2,1	9,7	35
DOR112M-06-3G	2,2	4,9	F	1,67	16,9	3,72	1,37	13,9	3,06	16,3	48
DOR132S-06-3G	3	6,3	F	2,28	23,1	4,7	1,87	18,9	3,93	32,2	68
DOR132M1-06-3G	4	8,3	F	3,04	30,7	6,3	2,5	25,2	5,1	43,3	70
DOR132M2-06-3G	5,5	11,5	F	4,1	46,3	8,7	3,43	38,7	7,1	54,4	75
DOR160M-06-3G	7,5	15,1	F	5,7	57	11,4	4,6	46	9,4	87,2	122
DOR160L-06-3G	11	25,2	F	8,3	81,3	19,1	6,8	66,6	15,7	177	140
DOR180L-06-3G	15	32,3	F	11,4	110	24,5	9,3	90,3	20,1	315	190
DOR200L1-06-3G	18,5	39,7	F	14	136	30,1	11,5	111	24,8	468	257
DOR200L2-06-3G	22	46,3	F	16,7	162	35,1	13,7	133	28,9	548	315
DOR225M-06-3G	30	59,6	F	22,8	221	45,2	18,7	181	37,2	884	308
DOR250M-06-3G	37	71,5	F	28,1	271	54,3	23,1	223	44,6	1196	410
DOR280S-06-3G	45	86,6	F	34,2	329	65,8	28,1	271	54,1	2338	475
DOR280M-06-3G	55	105	F	41,8	403	79,8	34,3	330	65,6	2797	550
DOR315S-06-3G	75	144	F	57	549	109	46,8	450	90	4741	915
DOR315M-06-3G	90	173	F	68,4	659	131	56,2	541	108	5822	995
DOR315L1-06-3G	110	208	F	83,6	805	158	68,7	662	130	6654	1175
DOR315L2-06-3G	132	249	F	100	962	189	82,5	794	155	7985	1225
DOR355M1-06-3G	160	299	F	121	1166	227	100	963	186	10386	1790
DOR355M2-06-3G	200	372	F	152	1464	282	125	1204	232	12413	1890
DOR355L-06-3G	250	455	F	190	1832	345	156	1504	284	13932	1920

**Dimensions cast iron motors in frame size 63...180 IE3**

Mounting arrangement IM 1001 (B3)

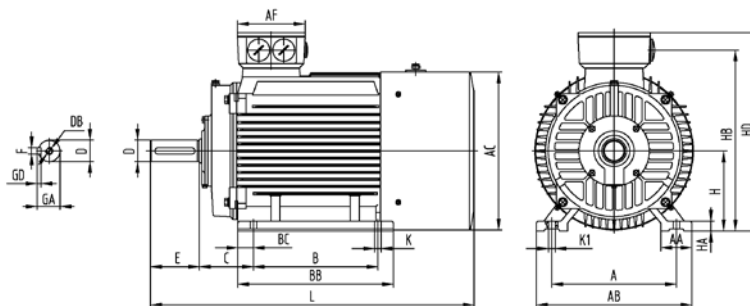

Type	Frame size	No. of poles	Dimensions according to IEC [mm]													
			H	A	B	C	AB	BB	BC	HD	AC	HB	HA	K	K1	L
			Dimensions according to DIN [mm]													
<b>IE3</b>			h	b	a	w1	f	e		m1	g	v	c	s		k
DOR80M1, M2	80	2...6	80	125	100	50	154	125	12,5	209	158	179	12	9	9	290
DOR90S	90S	2...6	90	140	100	56	178	130	15	231	176	199	14	10	10	320
DOR90L	90L	2...6	90	140	125	56	178	155	15	231	176	199	14	10	10	345
DOR100L, L1, L2	100L	2...6	100	160	140	63	203	180	20	251	199	220	14	12	12	385
DOR112M	112M	2...6	112	190	140	70	231	180	20	292	220	255	15	12	12	405
DOR132S, S1, S2	132S	2...6	132	216	140	89	264	190	25	330	259	295	16,5	12	12	467
DOR132M, M1, M2	132M	2...6	132	216	178	89	264	228	25	330	259	295	16,5	12	12	505
DOR160M, M1, M2	160M	2...6	160	254	210	108	320	274	25	416	315	373	20	15	15	583
DOR160L	160L	2...6	160	254	254	108	320	318	25	416	315	373	20	15	15	627
DOR180M	180M	2...6	180	279	241	121	355	315	35	465	360	405	22	15	15	665
DOR180L	180L	2...6	180	279	279	121	355	350	35	465	360	405	22	15	15	705

Type	Frame size	No. of poles	Dimensions according to IEC [mm]							
			AF	AA	D	E	F	GD	GA	DB
			Dimensions according to DIN [mm]							
<b>IE3</b>			n	d	l	u		t	d6/d7	
DOR80M1, M2	80	2...6	105	35	19	40	6	6	21,5	M6
DOR90S	90S	2...6	114	37	24	50	8	7	27	M8
DOR90L	90L	2...6	114	37	24	50	8	7	27	M8
DOR100L, L1, L2	100L	2...6	114	45	28	60	8	7	31	M8
DOR112M	112M	2...6	134	45	28	60	8	7	31	M10
DOR132S, S1, S2	132S	2...6	134	46	38	80	10	8	41	M12
DOR132M, M1, M2	132M	2...6	134	46	38	80	10	8	41	M12
DOR160M, M1, M2	160M	2...6	160	65	42	110	12	8	45	M16
DOR160L	160L	2...6	160	65	42	110	12	8	45	M16
DOR180M	180M	2...6	160	70	48	110	14	9	51,5	M16
DOR180L	180L	2...6	160	70	48	110	14	9	51,5	M16

Mounting arrangement IM 2001 (B35), IM 3001 (B5) without feet

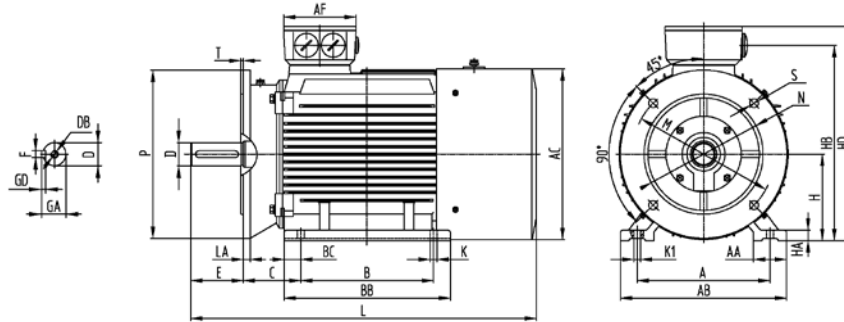

Mounting arrangement IM (B34), IM 3601 (B14) without feet

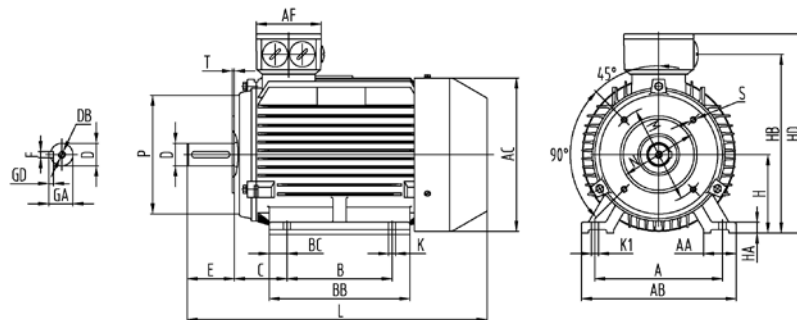

Type	Frame size	No. of poles	Flange B5							Small flange B14					Big flange B14				
			Dimensions according to IEC [mm]																
			M	N	P	T	LA	S <sup>1)</sup>	M	N	P	T	S	M	N	P	T	S	
			Dimensions according to DIN [mm]																
<b>IE3</b>			e1	b1	a1	f1	c1	s1 <sup>1)</sup>	e1	b1	a1	f1	s1	e1	b1	a1	f1	s1	
DOR80M1, M2	80	2...6	165	130	200	3,5	10	4 x M10	100	80	120	3	4 x M6	130	110	160	3,5	4 x M8	
DOR90S	90S	2...6	165	130	200	3,5	10	4 x M10	115	95	140	3	4 x M8	130	110	160	3,5	4 x M8	
DOR90L	90L	2...6	165	130	200	3,5	10	4 x M10	115	95	140	3	4 x M8	130	110	160	3,5	4 x M8	
DOR100L, L1, L2	100L	2...6	215	180	250	4	12	4 x M12	130	110	158	3,5	4 x M8	165	130	200	3,5	4 x M10	
DOR112M	112M	2...6	215	180	250	4	12	4 x M12	130	110	160	4	4 x M8	165	130	200	3,5	4 x M10	
DOR132S, S1, S2	132S	2...6	265	230	300	4	13	4 x M12	165	130	200	3,5	4 x M10	215	180	250	4	4 x M12	
DOR132M, M1, M2	132M	2...6	265	230	300	4	13	4 x M12	165	130	200	3,5	4 x M10	215	180	250	4	4 x M12	
DOR160M, M1, M2	160M	2...6	300	250	350	5	15	4 x M16	-	-	-	-	-	-	-	-	-	-	
DOR160L	160L	2...6	300	250	350	5	15	4 x M16	-	-	-	-	-	-	-	-	-	-	
DOR180M	180M	2...6	300	250	350	5	15	4 x M16	-	-	-	-	-	-	-	-	-	-	
DOR180L	180L	2...6	300	250	350	5	15	4 x M16	-	-	-	-	-	-	-	-	-	-	

<sup>1)</sup> Through hole, suitable for screws

### Dimensions cast iron motors in frame size 200...355 IE3

Mounting arrangement IM 1001 (B3)

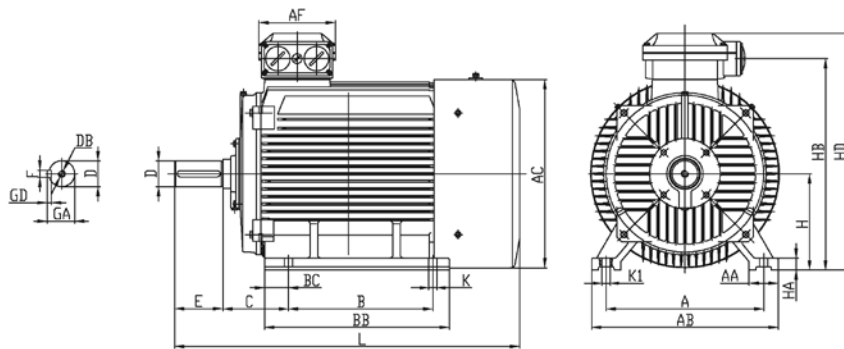

Type	Frame size	No. of poles	Dimensions according to IEC [mm]													
			H	A	B	C	AB	BB	BC	HD	AC	HB	HA	K	K1	L
			Dimensions according to DIN [mm]													
			h	b	a	w1	f	e		m1	g	v	c	s		k
DOR200L, L1, L2	200L	2...6	200	318	305	133	390	369	33	525	400	460	25	19	19	738
DOR225S	225S	4...6	225	356	286	149	435	370	46	562	450	501	28	19	19	817
DOR225M	225M	2	225	356	311	149	435	395	46	562	450	501	28	19	19	768
		4...6	225	356	311	149	435	395	46	562	450	501	28	19	19	842
DOR250M	250M	2	250	406	349	168	485	445	56	635	490	555	30	24	24	870
		4...6	250	406	349	168	485	445	56	635	490	555	30	24	24	870
DOR280S	280S	2	280	457	368	190	550	490	70	695	550	615	35	24	24	985
		4...6	280	457	368	190	550	490	70	695	550	615	35	24	24	1005
DOR280M	280M	2	280	457	419	190	550	540	70	695	550	615	35	24	24	1030
		4...6	280	457	419	190	550	540	70	695	550	615	35	24	24	1060
DOR315S	315S	2	315	508	406	216	630	570	84	870	620	758	45	28	28	1169
		4...6	315	508	406	216	630	570	84	870	620	758	45	28	28	1185
DOR315M	315M	2	315	508	457	216	630	680	84	870	620	758	45	28	28	1279
		4...6	315	508	457	216	630	680	84	870	620	758	45	28	28	1295
DOR315L1, L2	315L	2	315	508	508	216	630	680	84	870	620	758	45	28	28	1279
		4...6	315	508	508	216	630	680	84	870	620	758	45	28	28	1295
DOR355M, M1, M2	355M	2	355	610	560	254	730	750	68	990	710	877	52	28	28	1540
		4...6	355	610	560	254	730	750	68	990	710	877	52	28	28	1580
DOR355L	355L	2	355	610	630	254	730	750	68	990	710	877	52	28	28	1540
		4...6	355	610	630	254	730	750	68	990	710	877	52	28	28	1580

Mounting arrangement IM 1001 (B3)

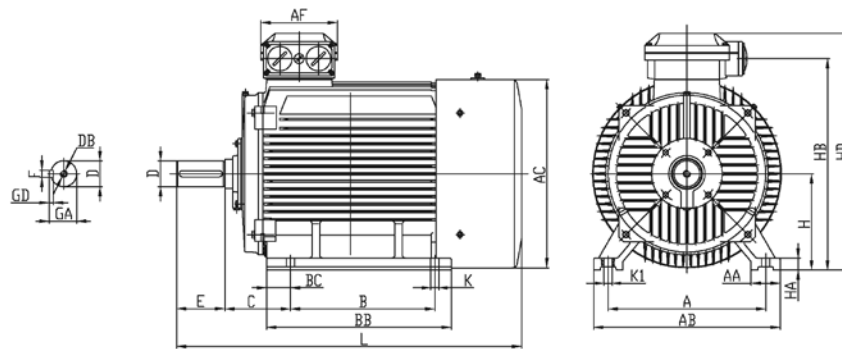

Type	Frame size	No. of poles	Dimensions according to IEC [mm]							
			AF	AA	D	E	F	GD	GA	DB
			Dimensions according to DIN [mm]							
<b>IE3</b>			n	d	l	u		t	d6/d7	
DOR200L, L1, L2	200L	2...6	196	70	55	110	16	10	59	M20
DOR225S	225S	4...6	196	75	60	140	18	11	64	M20
DOR225M	225M	2	196	75	55	110	16	11	60	M20
		4...6	196	75	60	140	18	11	64	M20
DOR250M	250M	2	222	80	60	140	18	11	64	M20
		4...6	222	80	65	140	18	11	69	M20
DOR280S	280S	2	222	85	65	140	18	11	69	M20
		4...6	222	85	75	140	20	12	79,5	M20
DOR280M	280M	2	222	85	65	140	18	11	69	M20
		4...6	222	85	75	140	20	12	79,5	M20
DOR315S	315S	2	288	120	65	140	18	11	69	M20
		4...6	288	120	80	170	22	14	85	M20
DOR315M	315M	2	288	120	65	140	18	11	69	M20
		4...6	288	120	80	170	22	14	85	M20
DOR315L1, L2	315L	2	288	120	65	140	18	11	69	M20
		4...6	288	120	80	170	22	14	85	M20
DOR355M, M1, M2	355M	2	350	120	75	140	20	12	79,5	M20
		4...6	350	120	100	210	28	16	106	M24
DOR355L	355L	2	350	120	75	140	32	14	85	M20
		4...6	350	120	100	210	28	16	106	M24

Mounting arrangement IM 2001 (B35), IM 3001 (B5) without feet

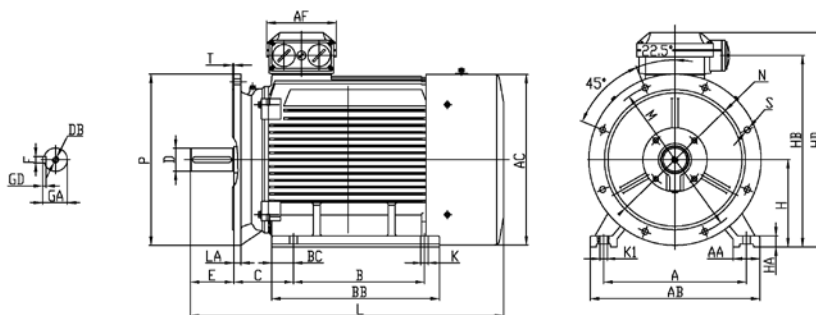

Type	Frame size	No. of poles	Flange B5					
			Dimensions according to IEC [mm]					
			M	N	P	T	LA	S <sup>1)</sup>
			Dimensions according to DIN [mm]					
<b>IE3</b>			e1	b1	a1	f1	c1	s1 <sup>1)</sup>
DOR200L, L1, L2	200L	2...6	350	300	400	5	17	4 x M16
DOR225S	225S	4...6	400	350	450	5	20	8 x M16
DOR225M	225M	2	400	350	450	5	20	8 x M16
		4...8	400	350	450	5	20	8 x M16
DOR250M	250M	2	500	450	550	5	22	8 x M16
		4...6	500	450	550	5	22	8 x M16
DOR280S	280S	2	500	450	550	5	22	8 x M16
		4...6	500	450	550	5	22	8 x M16
DOR280M	280M	2	500	450	550	5	22	8 x M16
		4...6	500	450	550	5	22	8 x M16
DOR315S	315S	2	600	550	660	6	22	8 x M20
		4...6	600	550	660	6	22	8 x M20
DOR315M	315M	2	600	550	660	6	22	8 x M20
		4...6	600	550	660	6	22	8 x M20
DOR315L1, L2	315L	2	600	550	660	6	22	8 x M20
		4...6	600	550	660	6	22	8 x M20
DOR355M, M1, M2	355M	2	740	680	800	6	25	8 x M20
		4...6	740	680	800	6	25	8 x M20
DOR355L	355L	2	740	680	800	6	25	8 x M20
		4...6	740	680	800	6	25	8 x M20

<sup>1)</sup> Through hole, suitable for screws











## Germany

### HEADQUARTERS

#### J. HELMKE & Co.

Ludwig-Erhard-Ring 7-9  
31157 Sarstedt  
Postfach 13 64  
31153 Sarstedt  
Tel.: +49 (0) 50 66 903 33-0  
Fax: +49 (0) 50 66 903 33-291  
E-Mail: helmke@helmke.de  
www.helmke.de

### WORKS HANNOVER

#### J. HELMKE & Co.

Garvensstraße 5  
30519 Hannover  
Postfach 89 01 26  
30514 Hannover  
Tel.: +49 (0) 511 87 03-0  
Fax: +49 (0) 511 86 39 30  
E-Mail: helmke@helmke.de  
www.helmke.de

#### HELMKE Orbis GmbH

Ludwig-Erhard-Ring 7-9  
31157 Sarstedt  
Postfach 12 03  
D-31152 Sarstedt  
Tel.: +49 (0) 50 66 903 33-0  
Fax: +49 (0) 50 66 903 33-145  
E-Mail: orbis@helmke.de  
www.helmke.de

## France

#### HELMKE S.à.r.l.

Z.I. -1 Allée Vert Bois  
BP 17  
68840 Pulversheim  
Tel.: +33 (0) 389 83 25 25  
Fax: +33 (0) 389 48 89 47  
E-Mail: helmke@helmke.fr  
www.helmke.fr

#### HELMKE S.à.r.l.

Bureau de Lyon  
107, Cours Albert Thomas  
69003 Lyon  
Tel.: +33 (0) 4 72 12 06 39  
Fax: +33 (0) 4 78 53 89 89  
E-Mail: helmke.lyon@helmke.fr  
www.helmke.fr

#### HELMKE Orbis S.à.r.l.

Z.I. -1 Allée Vert Bois  
BP 17  
68840 Pulversheim  
Tel.: +33 (0) 3 89 83 25 25  
Fax: +33 (0) 3 89 48 82 61  
E-Mail: helmke.orbis@helmke.fr  
www.helmke.fr

## The Netherlands

#### HELMKE B.V.

Elektrische machines en aandrijvingen  
Aalbosweg 24  
8171 MA Vaassen  
Postbus 195  
8170 AD Vaassen  
Tel.: +31 (0) 578 578 578  
Fax: +31 (0) 578 578 585  
E-Mail: info@helmke.nl  
www.helmke.nl

## Italy

#### HELMKE Italia S.r.l.

Via A. Volta, 18  
20094 Corsico (Mi)  
Tel.: +39 02 48 60 24 85  
Fax: +39 02 48 60 24 94  
E-Mail: info@helmke.it  
www.helmke.it

## Russia

#### J. HELMKE & Co.

Office Moscow  
M.Malinovskogo 6k1, Office 3  
RU-123298 Moscow  
Tel.: +7 495 50 44 118  
Fax: +7 499 50 44 122  
E-Mail: info@helmke.ru  
www.helmke.ru

## Spain

#### HELMKE Orbis España

Camino de Mundaiz no. 10-2°  
Ofic. 24-A  
20012 San Sebastián  
Tel.: +34 9 43 32 08 44  
Fax: +34 9 43 32 13 09  
E-Mail: info@helmke.es  
www.helmke.es

## Singapore

#### HELMKE Asia LLP

20 Maxwell Road  
#04-02H Maxwell House  
Singapore 069113  
Tel.: +65 6562 8151  
Fax: +65 6562 8150  
E-Mail: info@helmke.sg  
www.helmke.sg