

Household burners





7-16

Oil burners
15-540 kW

17-23

Gas Burners
15-550 kW





For more than half a century, we have delivered environmentally-friendly and energy-efficient combustion solutions for our customers.

The customer has always been the focal point of our business. Perhaps this is the reason why we are known for our company slogan, "Oilon – the warm way".



We are a family-owned technology company, founded in 1961. We have decades of experience in providing heating systems for single-family homes, large buildings, and district heating networks as well as for a multitude of industrial applications and processes.

As a heating system specialist, we offer a versatile range of heating options for both single-family homes and other small and medium-sized buildings.



Our extensive portfolio provides a heating solution for almost any need: ground source heat pumps, air-to-water heat pumps, oil and gas burners as well as hybrid solutions integrating several different energy sources.

As a Finnish company, we recognize that long, harsh winters place exceptional demands on the reliability of heating equipment.

Through our extensive service network, we are able to provide a comprehensive selection of maintenance services and spare parts, ensuring a long and cost-effective life for our products.

Oilon household burners

We offer a versatile selection of burners for heating single-family homes and other small and medium-sized buildings as well as for use in industrial applications. Select your burner based on the required heating capacity and fuel type.

Oilon burners are especially suited for hot water boilers, steam boilers, and hot air generators. They can be used in both forced-draught and induced-draught combustion chambers, and in a wide range of different conditions.

All models feature automatic flame monitoring. Burner operation is controlled by a program relay, which takes care of all the necessary program stages automatically.

Oilon oil burners are designed and manufactured in accordance with standards EN 267 and EN 298 and gas burners with EN 676.

All oil burners presented in this brochure are suitable for firing light fuel oil. For applications requiring renewable heating oils, please contact us, and we will determine which burner solution is best for you.

Our gas burners are compatible with both natural gas and liquefied petroleum gas. In either case, the structure of the burner will be identical. However, burner adjustments and the gas supply pressure depend on the fuel; for further details, refer to your burner's operation and maintenance manual.

Oil burners



BF 1 FUV HC, BF 1 KSV HC

Technical data

BURNER	BF 1 FUV HC	BF 1 KSV HC
Capacity range, kW kg/h	15–55 1.3–4.6	35–90 3.0–7.6
Input power W/A	368/1.73	368/1.73
Burner motor – Mains voltage, 50 Hz – Rating, W – Current, A	1~230 V 110 0.9	1~230 V 110 0.9
Control unit	LMO14113C2E	LMO14113C2E
Flame detector	QRB4	QRB4
Oil pump	AS47CK	AS47CK
Oil hose connection – suction – return	G1/4" G1/4"	G1/4" G1/4"
Emission class, EN267	4 (ErP)	4 (ErP)
Weight, kg	10	10

Dimensions

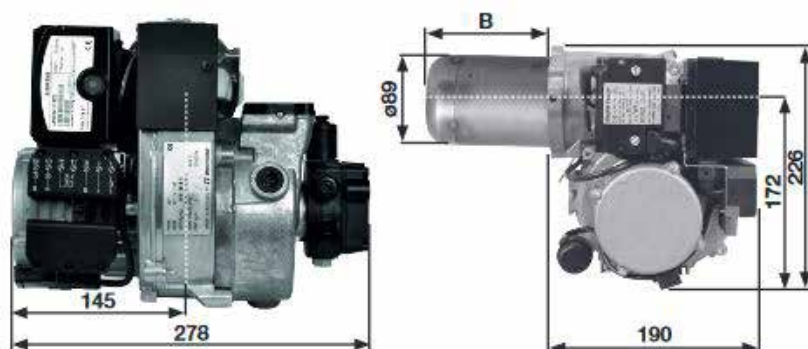

BURNER	B	Boiler flange and gasket's share	Combustion head's free length
BF 1 FUV HC	133	34	99
BF 1 KSV HC	147	33	114

Working diagrams

BF 1 FUV HC

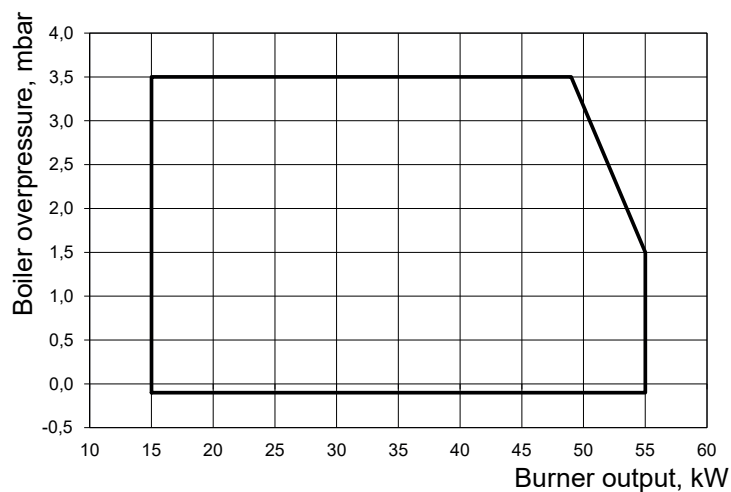

BF 1 KSV HC

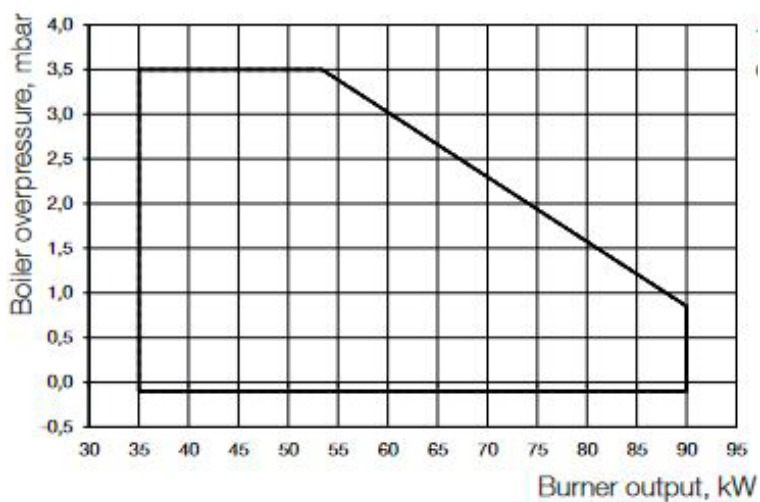

ST 146 KS

Technical data

BURNER	ST 146 KS
Capacity, kW	39-119
kg	3.3-10
Input power W/A	299/0.95
Burner motor	
- Mains voltage, 50 Hz	1~230 V
- Rating, W	125
- Current, A	0.95
Control unit	LMO14113C2E
Flame detector	QRB4
Oil pump	AS47CK
Oil hose connection	
- suction	G1/4"
- return	G1/4"
Emission class, EN267	4 (Erp)
Weight, kg	13

Dimensions

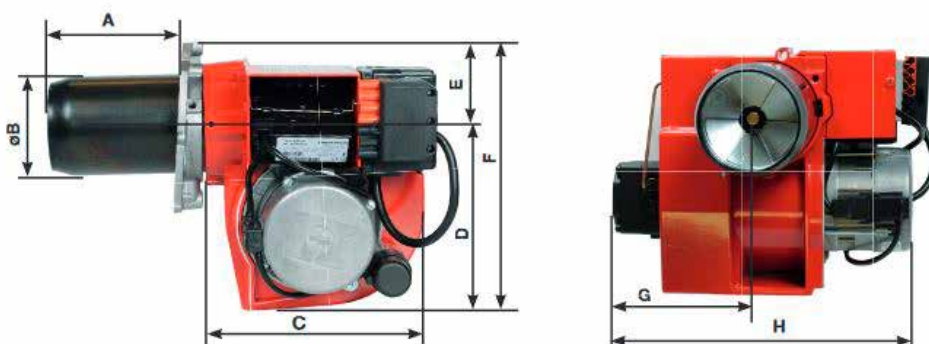

BURNER	A	ØB	C	D	E	F	G	H	I*
ST 146 KS	115.5	109	237	202	54	258	158	295	200

I*= Minimum height from floor

Working diagrams

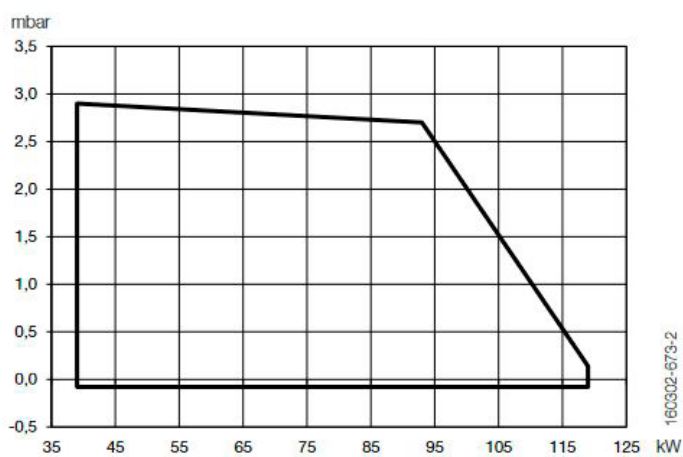

B 30 A L, B 30 A2.2H

Technical data

BURNER	B 30 A L	B 30 A2.2H
Capacity, kW	72-200	55-175
kg	6.0-17.0	4.5-15.0
Input power W/A	598/2.6	598/2.6
Burner motor		
- Mains voltage, 50 Hz	1~230 V	1~230 V
- Rating, W	180	180
- Current, A	1.3	1.3
Control unit	LMO14.113C2E	LMO24.255C2E
Flame detector	QRB4	QRB4
Oil pump	AS47CK	A2L65CK
Oil hose connection		
- suction	G1/4"	G1/4"
- return	G1/4"	G1/4"
Emission class, EN267	2	4 (ErP)
Weight, kg	16	19

Dimensions

B 30 A L

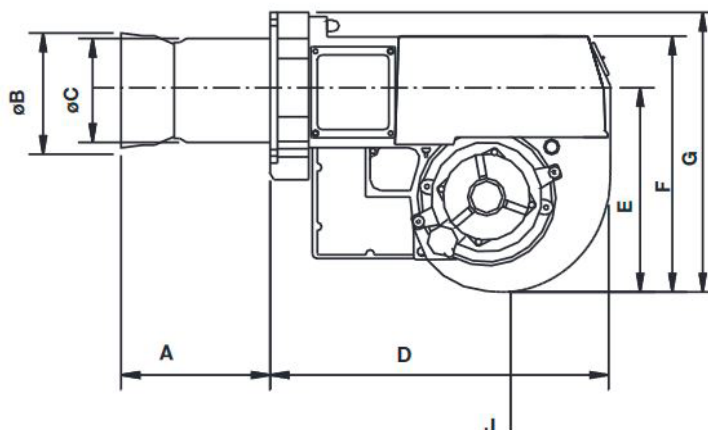
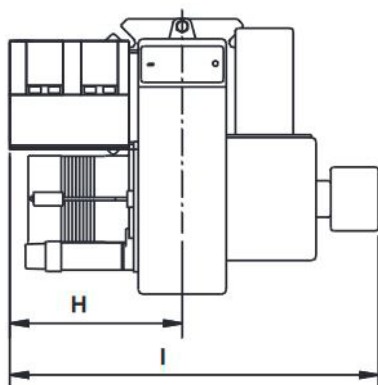

B 30 A2.2H

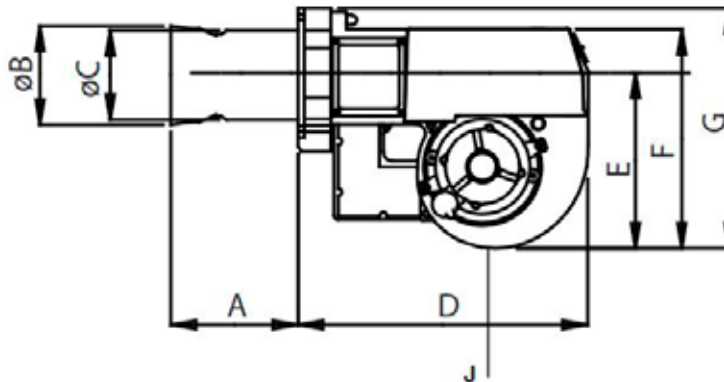
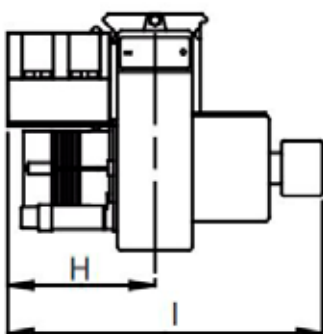

BURNER	A	øB	øC	D	E	F	G	H	I	J*
B 30 A L	187	108	108	372	220	281	303	188	415	200
B 30 A2.2H	174	108	108	372	220	281	303	188	415	200

J*= Minimum height from floor

Working diagrams

B 30 A L

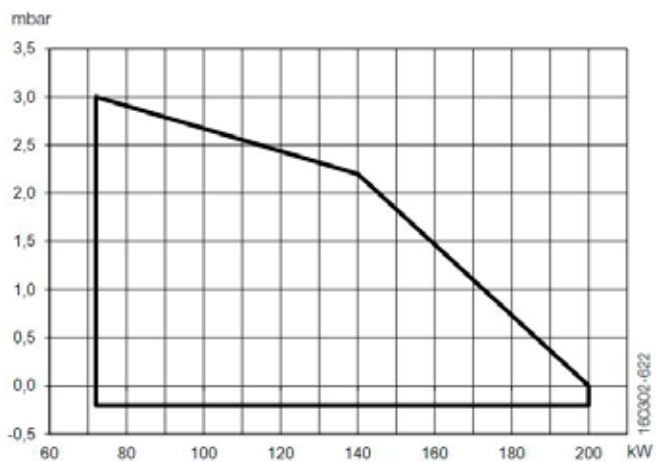

B 30 A2.2H

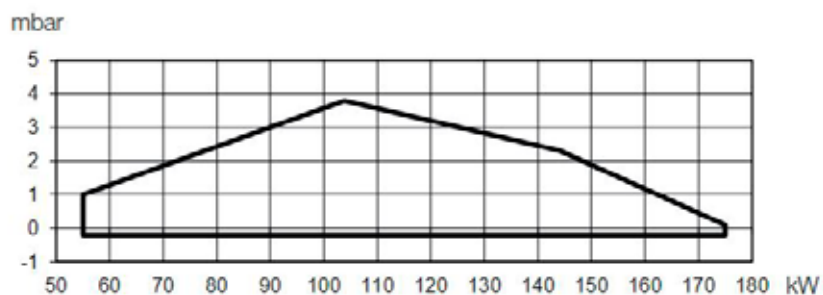

B 40, B 40 A2.2H, B 45 A2.2H

Technical data

BURNER	B 40	B 40 A2.2H	B 45 A2.2H
Capacity, kW	107-350	110-320	102-540
kg	9.0-29.5	9.3-27.0	8.6-45.5
Input power W/A	688/3.03	697/3.03	1065/4.63
Burner motor			
- Mains voltage, 50 Hz	1~230 V	1~230 V	1~230 V
- Rating, W	250	250	450
- Current, A	1.7	1.7	4.63
Control unit	LMO14.113C2E	LMO24.255C2E	LMO24.255C2E
Flame detector	QRB4	QRB4	QRB4
Oil pump	AS67CK	A2L65C-75C	A2L75CK
Oil hose connection			
- suction	G1/4"	G1/4"	G1/4"
- return	G1/4"	G1/4"	G1/4"
Emission class, EN267	4 (ErP)	4 (ErP)	2
Weight, kg	23	23	34

Dimensions

B 40, B 40 A2.2H

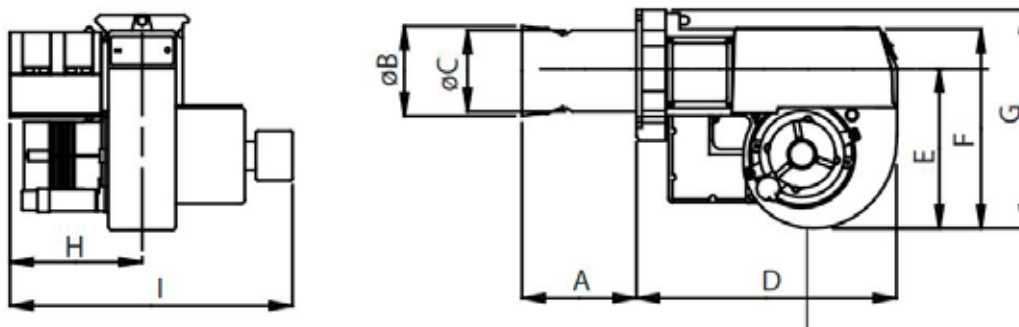

B 45 A2.2H

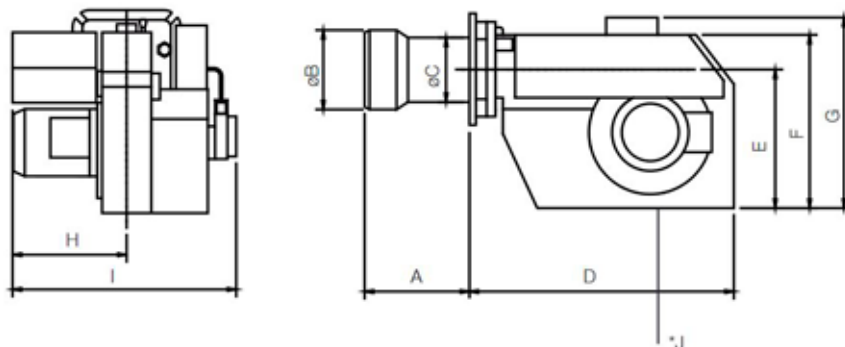

BURNER	A	øB	øC	D	E	F	G	H	I	J*
B 40	172	126	114	420	260	310	360	195	400	200
B 40 A2.2H	174	130	114	420	260	310	360	207	435	200
B 45 A2.2H	240	159	134	480	252	328	335	262	515	200

J*= Minimum height from floor

Working diagrams

B 40

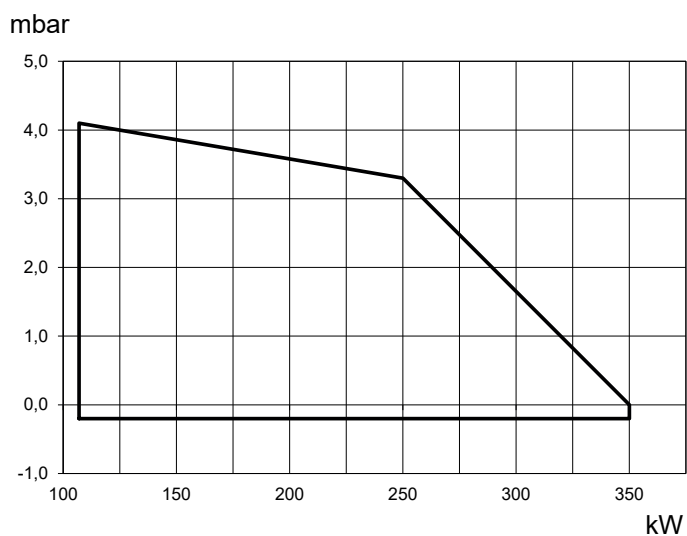

B 40 A2.2H

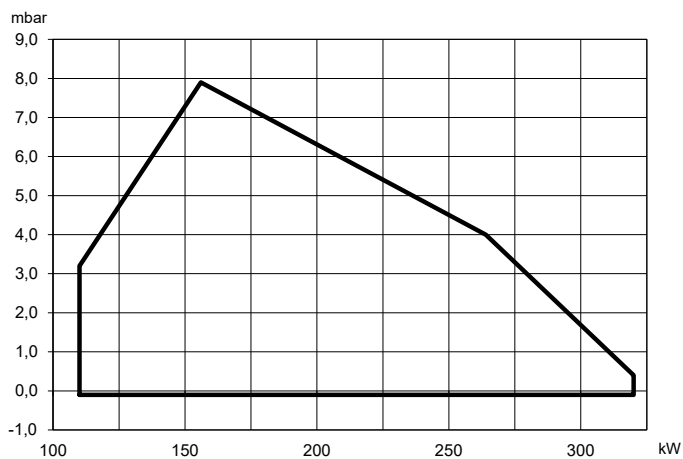

B 45 A2.2H

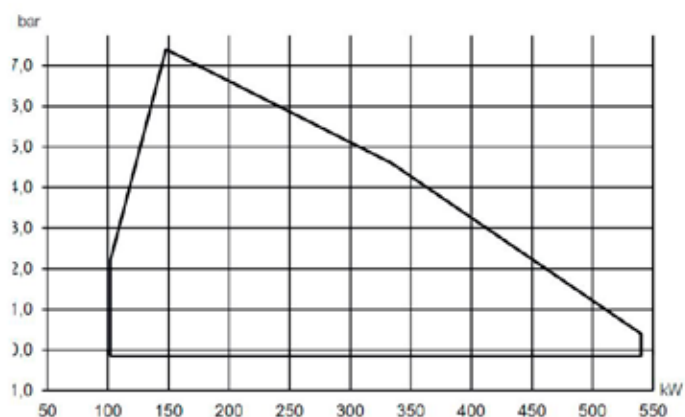

Gas Burners



BFG 1 H2 HC, BFG 1 H3 HC

Technical data

BURNER	BFG 1 H2 HC	BFG 1 H3 HC
Capacity range (kW), natural gas	15-65	25-100
Capacity range (kW), liquefied petroleum gas	15-65	25-100
Input power W/A	184/1.15	265/1.15
Burner motor		
- Mains voltage, 50 Hz	1~230 V	1~230 V
- Rating, W	110	110
- Current, A	0.9	0.9
Control unit	LME11.230C2E	LME11.230C2E
Flame detector	ionization electrode	ionization electrode
Gas valve	GBLD-055	GBLD-055
Gas connection	1/2"	1/2"
Emission class, EN 676	3	3
Weight, kg	13	13

Dimensions

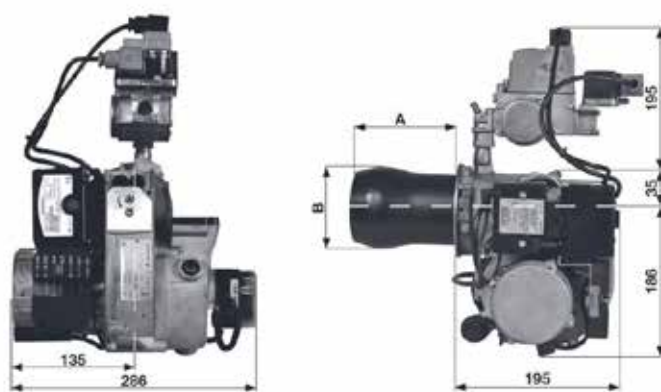

BURNER	A	Boiler flange and gasket's share	Combustion head's free length	B
BFG 1 H2 HC	115	29	86	Ø89
BFG 1 H3 HC	140	20	120	Ø103

Working diagrams

BFG 1 H2 HC

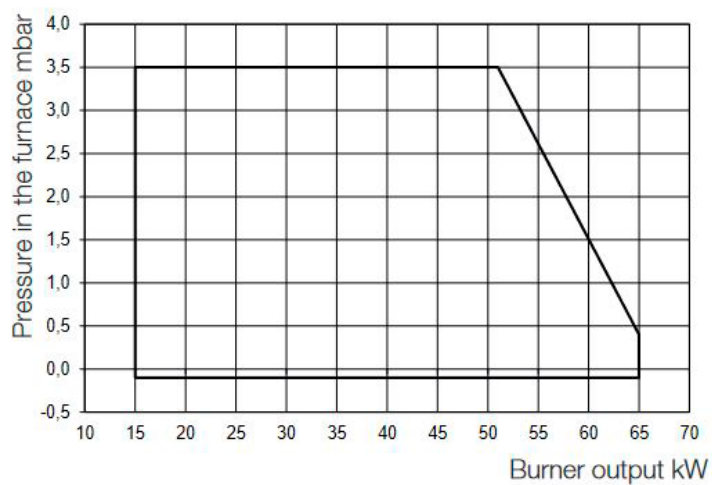

BFG 1 H3 HC

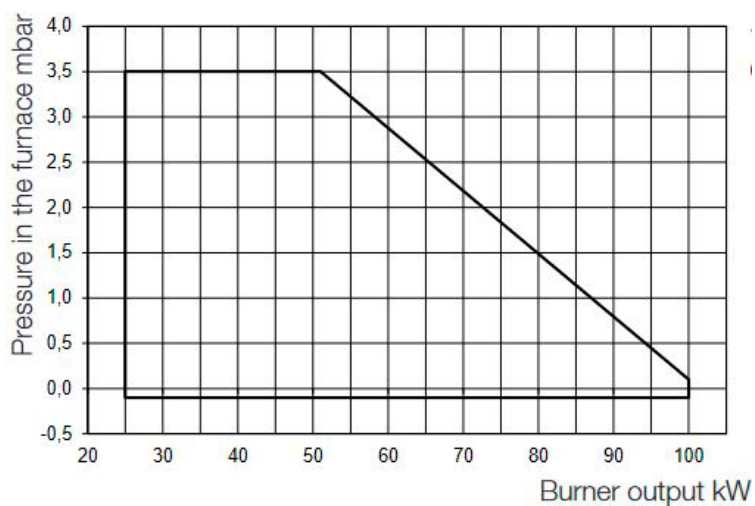

STG 146/2

Technical data

BURNER	STG 146/2
Capacity range (kW), natural gas	41–133
Capacity range (kW), liquefied petroleum gas	47–144
Input power W/A	219/2.5
Burner motor	
– Mains voltage, 50 Hz	1~230 V
– Rating, W	125
– Current, A	0.95
Control unit	LME21
Flame detector	ionization electrode
Gas valve	MBDLE 407
Gas connection	1"
Emission class, EN 676	2
Weight, kg	15

Dimensions

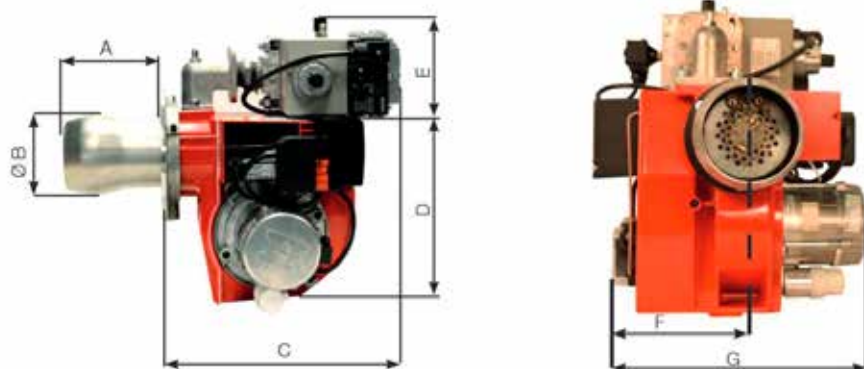

BURNER	A	øB	C	D	E	F	G	J	K	L	M
STG 146/2	122	103	340	253	135	165	305	ø103	ø109.5	ø145	23.5

Working diagrams

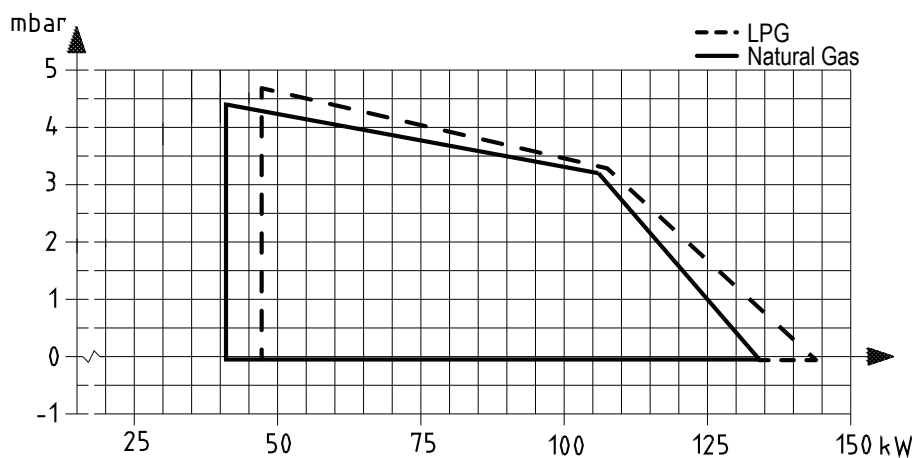

BG 400, BG 400-2

Technical data

BURNER	BG 400	BG 400-2
Capacity range (kW), natural gas	61–320	61–325
Capacity range (kW), liquefied petroleum gas	61–350	61–350
Input power W/A	506/2.2	506/2.2
Burner motor		
– Mains voltage, 50 Hz	1~230 V	1~230 V
– Rating, W	250	250
– Current, A	1.7	1.7
Control unit	LME11.230C2E	LME22.232C2E
Flame detector	ionization electrode	ionization electrode
Gas valve	MBDLE 407	MBZRDLE 407
Gas connection	1"	1"
Emission class, EN 676	2	2
Weight, kg	24	28

Dimensions

BG 400

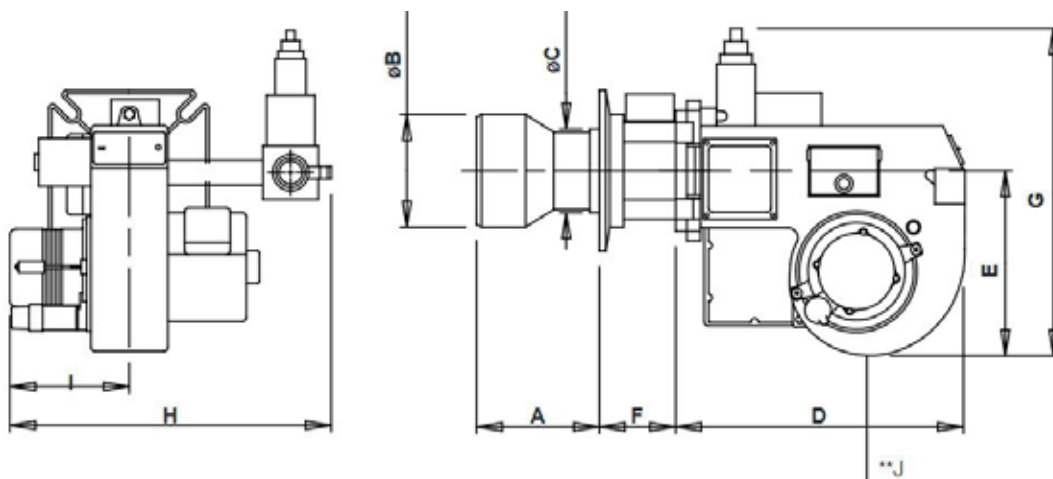

BG 400-2

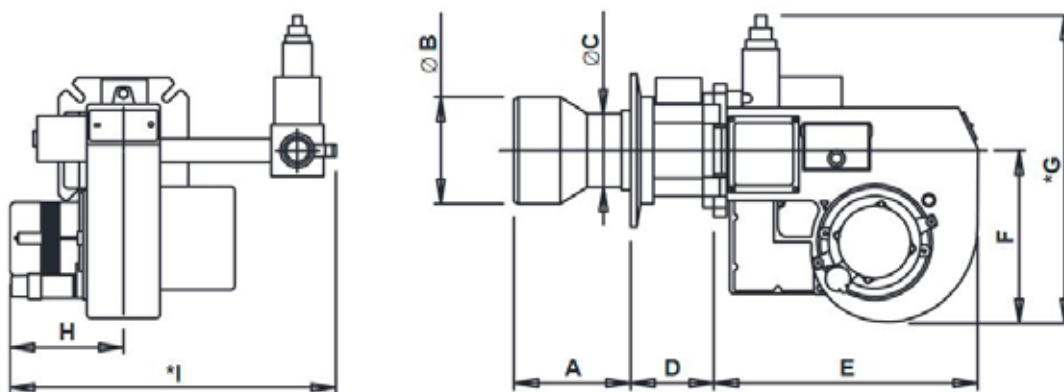

BURNER	A	B	C	D	E	F	G	H	I	J
BG 400	172	ø140	ø108	100	410	250	410*	192	506**	200***
BG 400-2	172	ø140	ø108	100	410	250	410*	192	506**	200***

* The dimensions may vary depending on the components used.

** The dimension given here is a maximum dimension, but may vary depending on the components used.

*** The recommended minimum height from floor level.

Working diagrams

BG 400

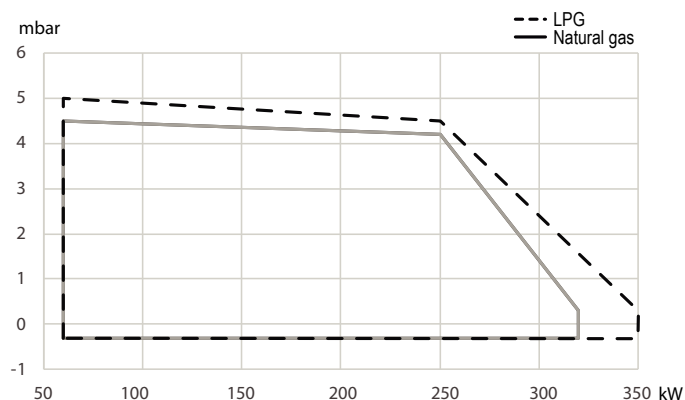

BG 400-2

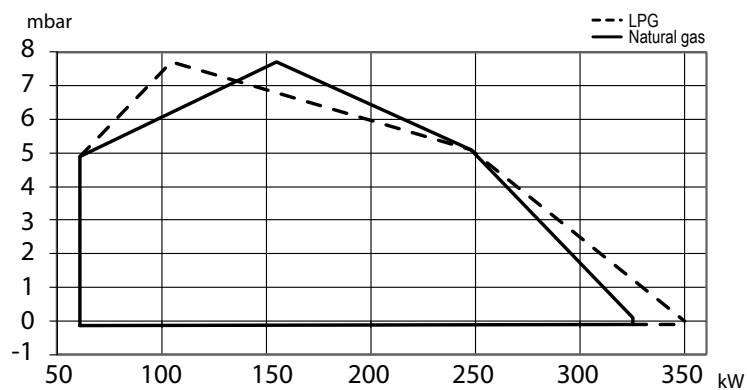

BG 450-2

Technical data

BURNER	BG 450-2
Capacity range (kW), natural gas	120–550
Capacity range (kW), liquefied petroleum gas	120–550
Input power W/A	759/3.3
Burner motor	
– Mains voltage, 50 Hz	1~230 V
– Rating, W	450
– Current, A	3.3
Control unit	LME22.232C2E
Flame detector	ionization electrode
Gas valve	MBZRDLE 412
Gas connection	1 1/2"
Emission class, EN 676	3
Weight, kg	50

Dimensions

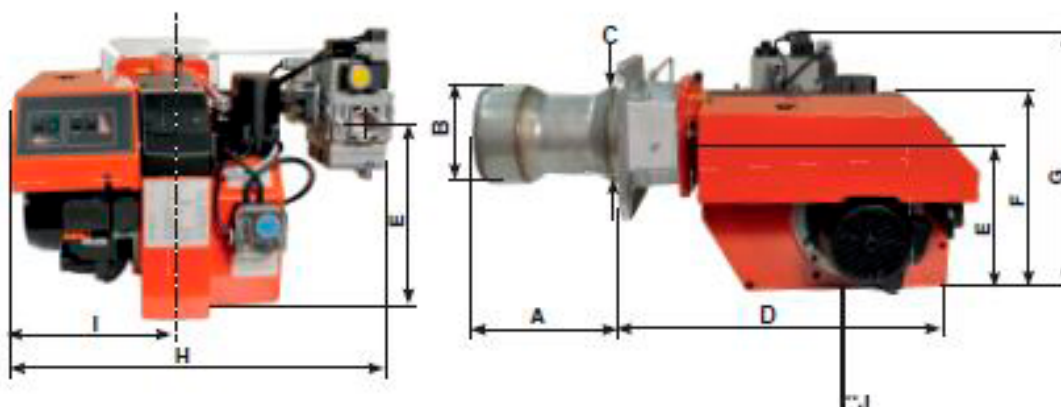

BURNER	A	B	C	D	E	F	G	H	I	J**
BG 450-2	256	ø160	ø162	538	252	328	500*	640*	262	200

* The dimension given here is a maximum dimension, but may vary depending on the components used.

*** The recommended minimum height from floor level.

Working diagrams

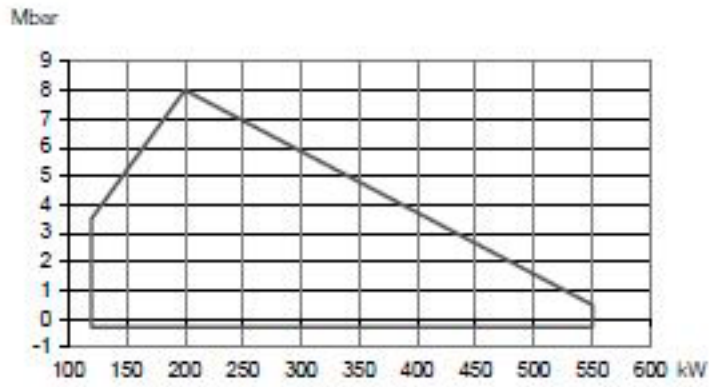

Mounting a burner to a boiler

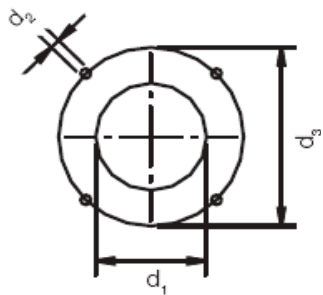

BURNER	d1	d2	d3
BF 1 FUV HC	ø95	M8	ø130–150
BF 1 KSV HC			
BFG 1 H2 HC	ø95	M8	ø125–150
BFG 1 H3 HC	ø115	M8	ø145
ST 146 KS	ø95	M10	ø125–150
B 30 A2.2H	ø115	M10	ø160–200
B 30 A L			
B 40	ø120	M14	ø200–250
B 40 A2.2H			
B 45 A2.2H	ø 170	M14	ø 224–270
STG 146/2	ø115	M10	ø140–170
BG 400	ø150	M10	ø175–240
BG 400-2			
BG 450-2			

Accessories

Oilon Plus

With the Oilon Plus filter and deaerator unit, only a single hose is required between the oil tank and the burner, making for a more environmentally-friendly system. The unit reduces wear and tear and protects the burner from faults caused by impurities in the oil (from the oil tank, the hose or the oil itself), reducing the need for cleaning and maintenance. Oilon Plus is suitable for burners in the 10–400 kW capacity range.

An Oilon Plus single-hose system is a neat and elegant solution that not only filters the oil effectively but also removes any gas bubbles in the stream. A major benefit of a single-hose system is that there is no risk of oil leaks caused by a break in the return line.

The Oilon Plus single-hose system is intended for single family homes and other small buildings. The system is easy to install in both existing and new buildings with oil heating. If installed in an existing system, the return inlet is first plugged, and the Oilon Plus unit installed in the suction pipe. In new buildings, only a single hose needs to be installed between the tank and the burner.



Lämpöparoni electric immersion heaters

Oilon offers automatic backup immersion heaters for oil heating systems and ground-source heat pump systems.

Single-stage heaters

- 3.0 kW (VB 3010)
- 4.5 kW (VB 4510)
- 6.0 kW (VB 6010)

Two-stage heaters

- 6.0 kW (VB 6001)
- 9.0 kW (VB 9001)



Single-stage immersion heaters are equipped with a three-pole control thermostat. When powered on, the heater will always operate at full capacity. Two-stage immersion heaters have a four-pole thermostat, and the heater operates in two stages (at partial capacity or at full capacity).

A Lämpöparoni electric immersion heater comprises a heating element unit, which can be installed in an R2" threaded port, as well as a control box with a terminal strip for power cables, main switch, limit thermostat (for overheat protection), control thermostat, and a power indicator light for the heating element.

Oilon customer services and webshop



28

Implementation and maintenance services

We have extensive expertise in combustion technology and a comprehensive understanding of various processes. Through our network of partners, we offer reliable commissioning, maintenance, and training services for all needs. Our expertise ensures clean and environmentally-friendly combustion and an optimal coefficient of performance for your system.

Technical support

Our technical support service is intended for retailers, maintenance companies, and end customers. If you have any questions about technical issues or warranty, please contact us. Additionally, we deliver modernization projects covering everything from design and planning to implementation and delivery with high skill and expertise.

Spare part services

Our spare part services will support you throughout your installation's lifecycle.

- spare part recommendations for both new and existing systems
- spare parts for servicing and maintenance

Spare parts store

For repair and maintenance companies and retailers, our online store provides a direct and convenient way to obtain spare parts. Contact our spare parts sales service and we will provide you with a password to access our spare parts webshop.

<http://webshop.oilon.com>



Modern training facility



We provide high-level training for our products, and the goal of our product training is to improve the professional skills of installation and maintenance companies.

Our theoretical sessions focus on key considerations for our burners' operating environment and components.

Practical training, in turn, covers topics such as burner adjustment and fault diagnostics.

We also underline the importance of low emission values for the environment.





For several decades, Oilon has delivered heating systems for single-family homes and industrial operators alike.

Our extensive portfolio provides a heating solution for almost any need: ground source heat pumps, air-to-water heat pumps, oil and gas burners as well as hybrid solutions integrating several different energy sources. We offer a multitude of new eco-friendly heating solutions.

The customer has always been the focal point of our business. Perhaps this is the reason why we are known for our company slogan, "Oilon – the warm way".

OILON OY

Metsä-Pietilänkatu 1, P.O. Box 5, FI-15801 Lahti, Finland
Tel.: +358 3 85 761 Fax: +358 3 857 6239
E-mail: info@oilon.com, www.oilon.com

oilon[®]