

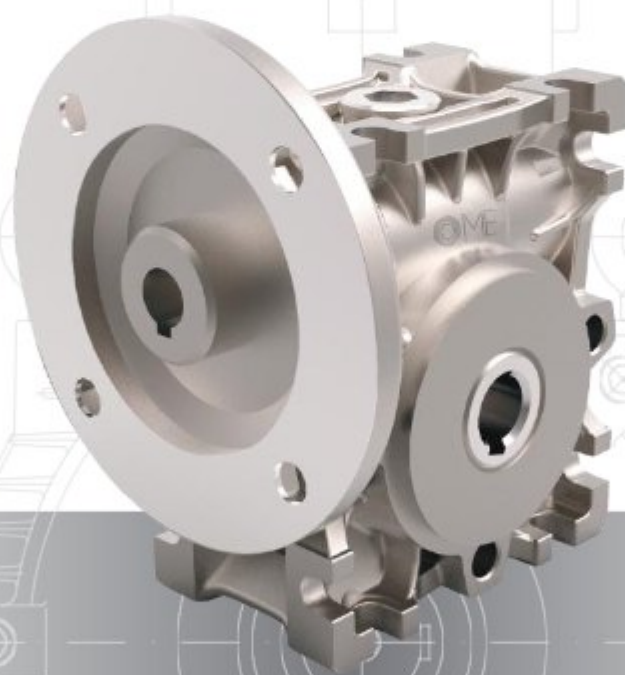

OMGB  
GEAR BOX SERIES

[www.omemotors.com](http://www.omemotors.com)





## GENERAL INFORMATION

OME Electric Motors Information	01
OMGB Series Introduction	03
Technical Data	08
Overall Dimension	10

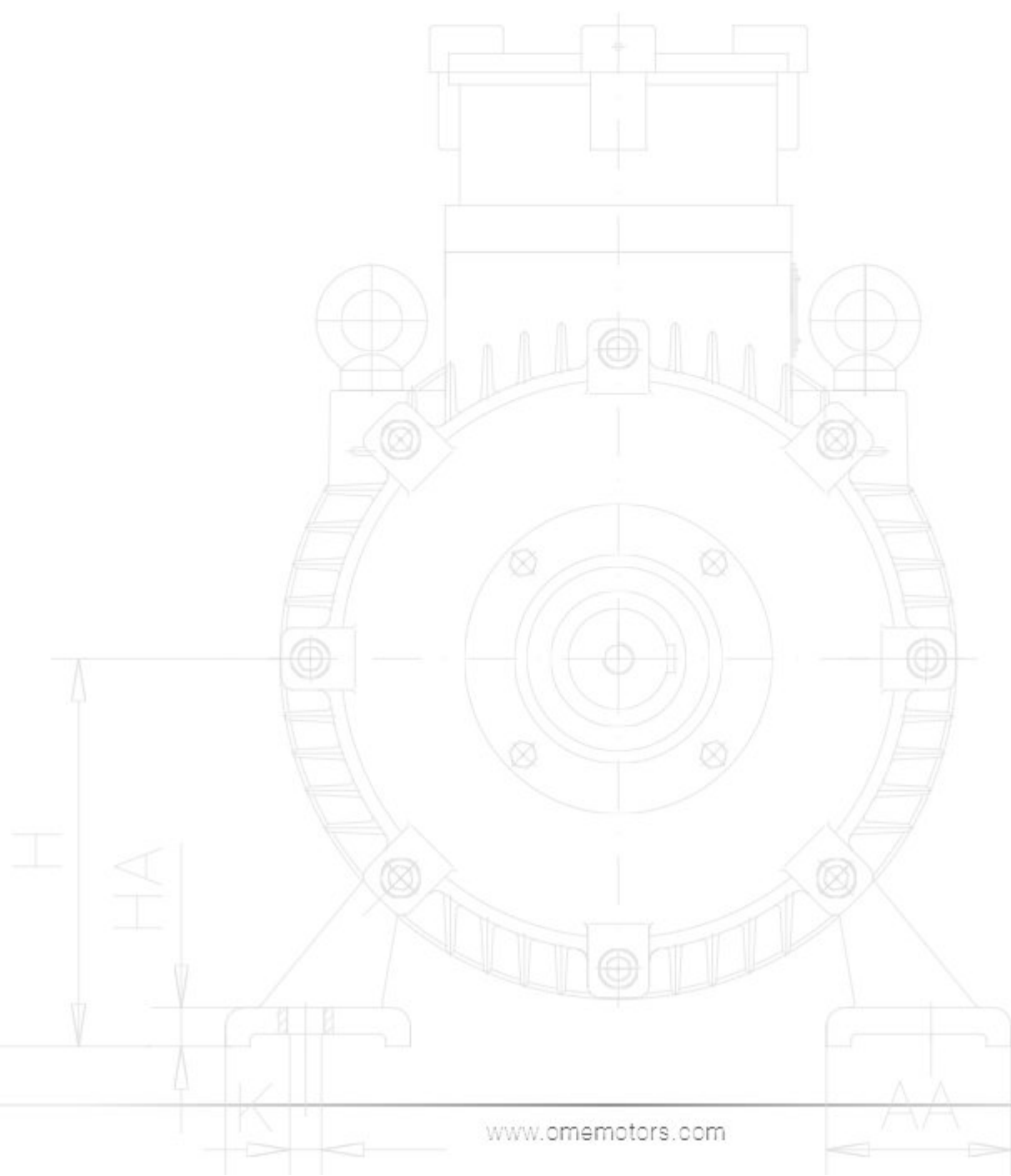



OMGB

GEAR BOX SERIES

[www.omemotors.com](http://www.omemotors.com)

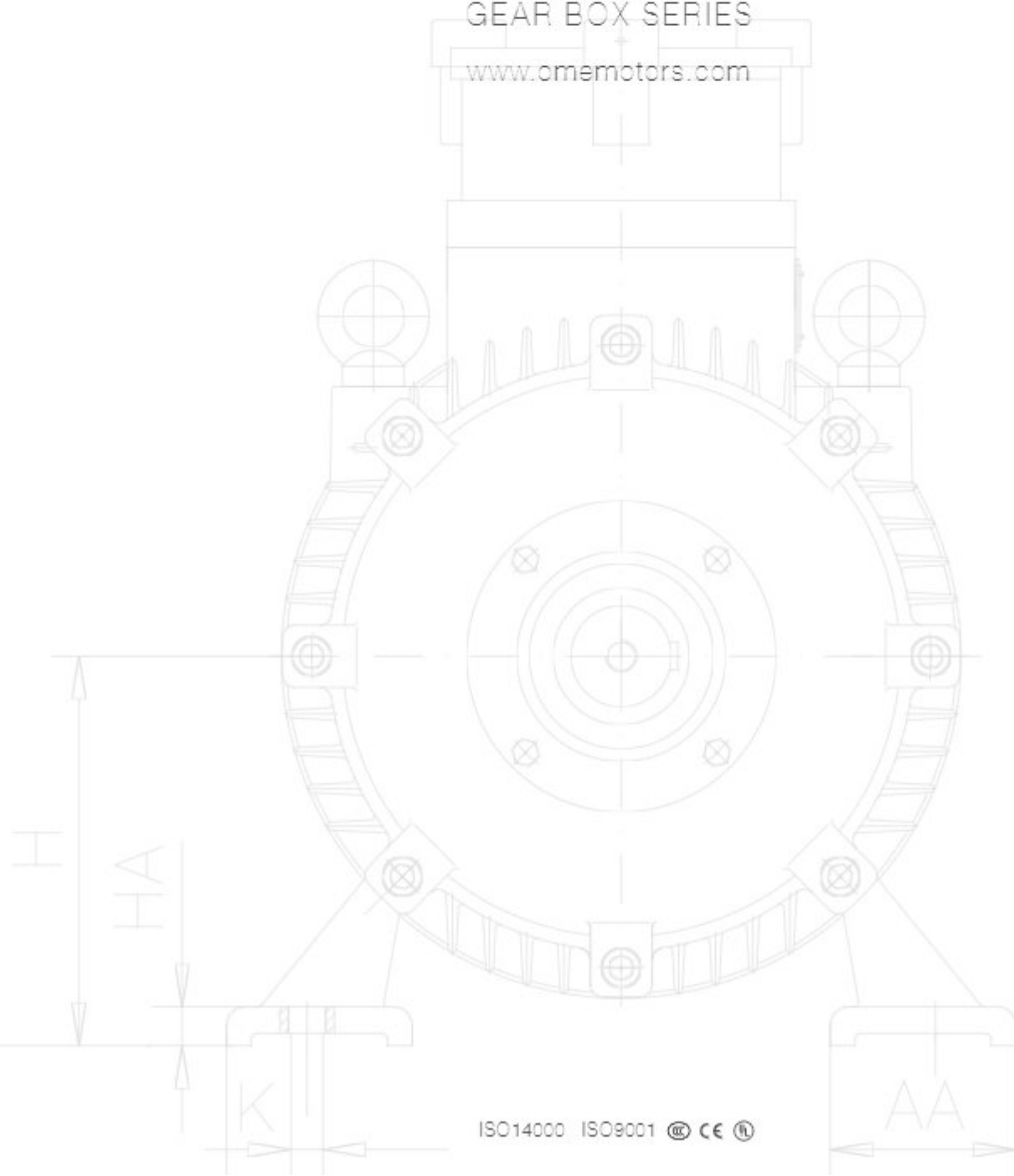



## OMGB GEAR BOX SERIES

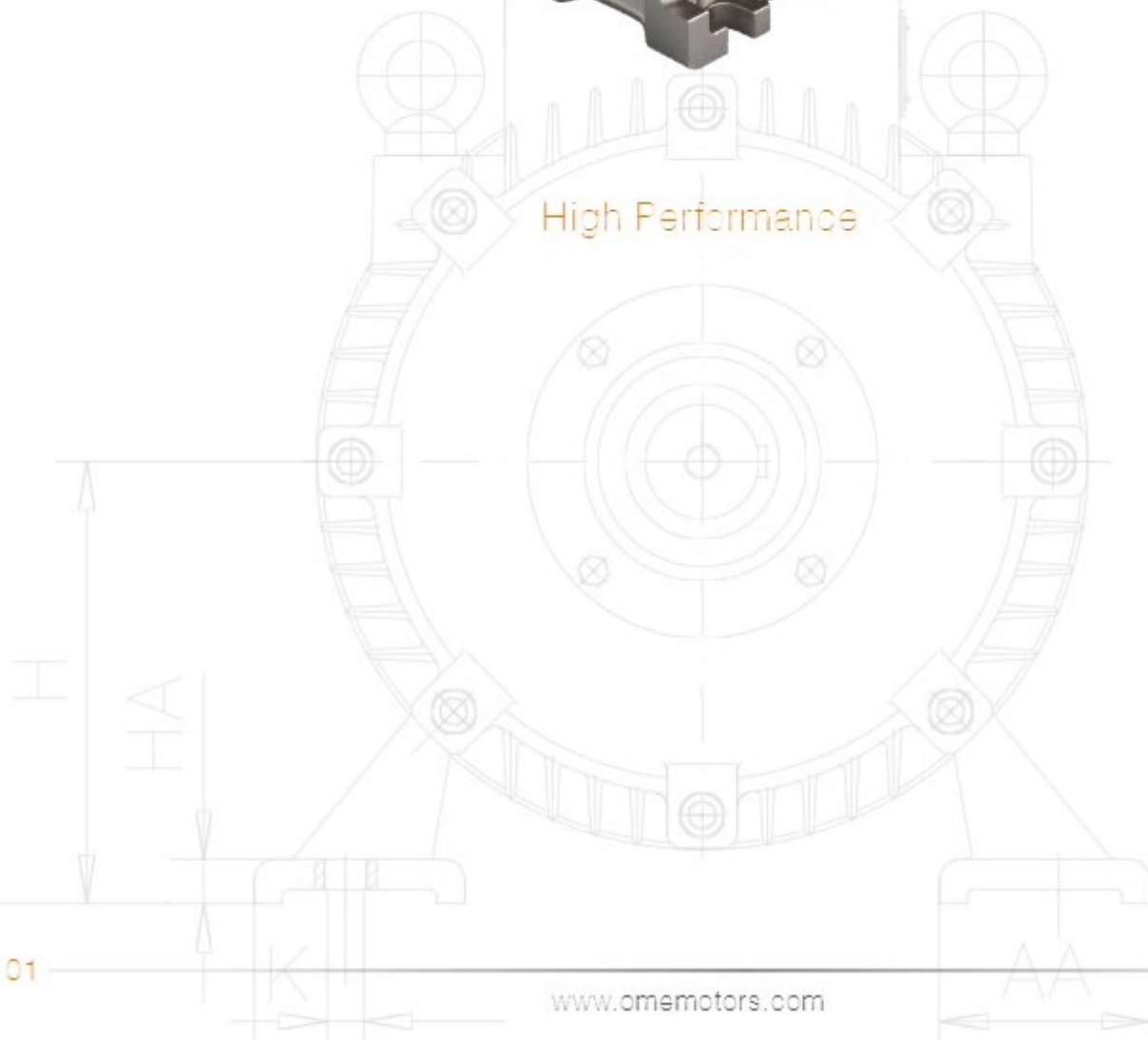

## OME Electric Motors and Orsatti Group

OME is a well-established global reality born from the Orsatti family's long experience in the electrical machinery sector and characterized by a history in continuous evolution.

The key points that distinguish the Orsatti Group are in particular:

- Technical experience of over 50 years
- The continuous research for new solutions to increase the performance of our electric motors
- Development of technical solutions in compliance with current standards
- The tailor-made service to customize the motors on customer request
- The wide range of production to meet any market need
- The constant research for suitable solutions to increase the efficiency of our electric motors
- Compliance with the standards required for energy saving and environmental protection

### MISSION

Our mission is to be a leading company in the production of electric motors at an international level.

### VISION

Our vision is to design and manufacture highly customized motors, meeting the most varied customer requirements, managing to make competitive even the smallest realities.

### VALUES

- The high quality of production, sales, service and maintenance;
- Intelligent and low costs logistics;
- Providing motors, services and expertise to save energy and improve customer processes throughout the life cycle of our products and beyond.



## Series OMGB

### THE ADVANTAGES OF WORM REDUCER

High quality Aluminum alloy ,appearance elegant, efficient radiator, high carrying ability. installed in multi-surfaces,hollow output shaft, various input and output type, conjoin other transmission machinery easily. Small size, constriction compact, lightweight, and save place for mounting. Run steadily and low noise. High reliability and high efficiency.

### SIGNS AND MARKS

The signs consist of: model,type (centre distance),nominal transmission ratio, the kind of added electric motor and the way of input of output.Their meanings as shown in table 1,chart1.

#### Sign explanation

(Table 1)

OMGBM	With input flange (using with electric motor)
OMGB	With input shaft
25-30-40-50-63-75-90-110-130-150-185	Type(centre distante)
7.5-10-15-20-25-30-40-50-60-80-100	Nominal ratio
Y 0.18	With electric motor the power is 0.18KW
Z 0.18	With breaking motor,the power is 0.18KW
F(1-2) - FL(1-2)	Output flange and mounting position (F-output short flang. FL-output long flang)
TA	With torque arm
YZ	With extention worm shaft
DZ1-DZ2	With single output shaft
SZ	With double output shaft



## MODEL DESIGNATION

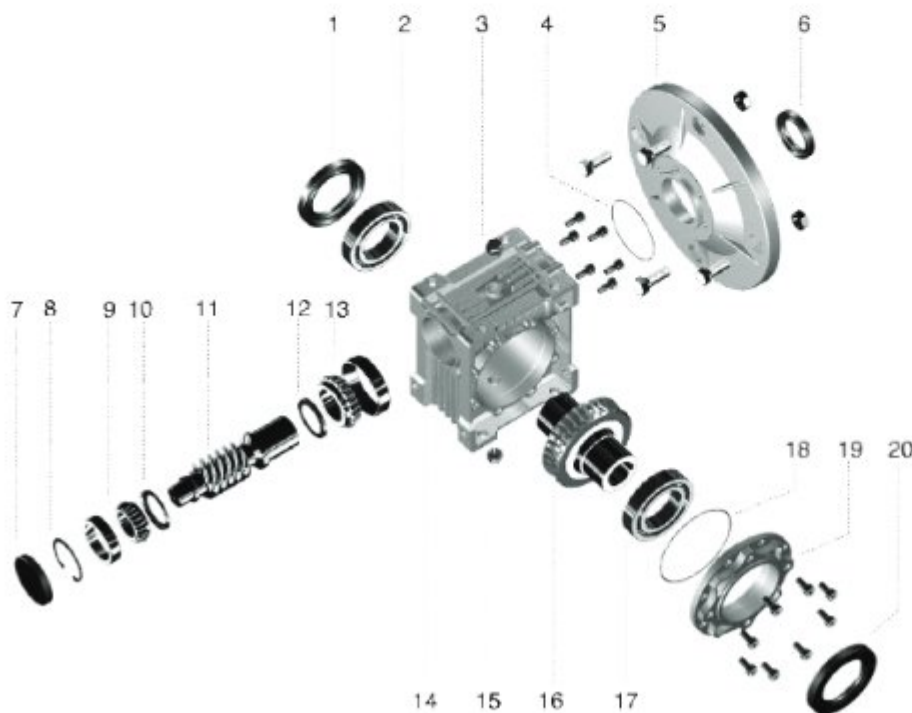
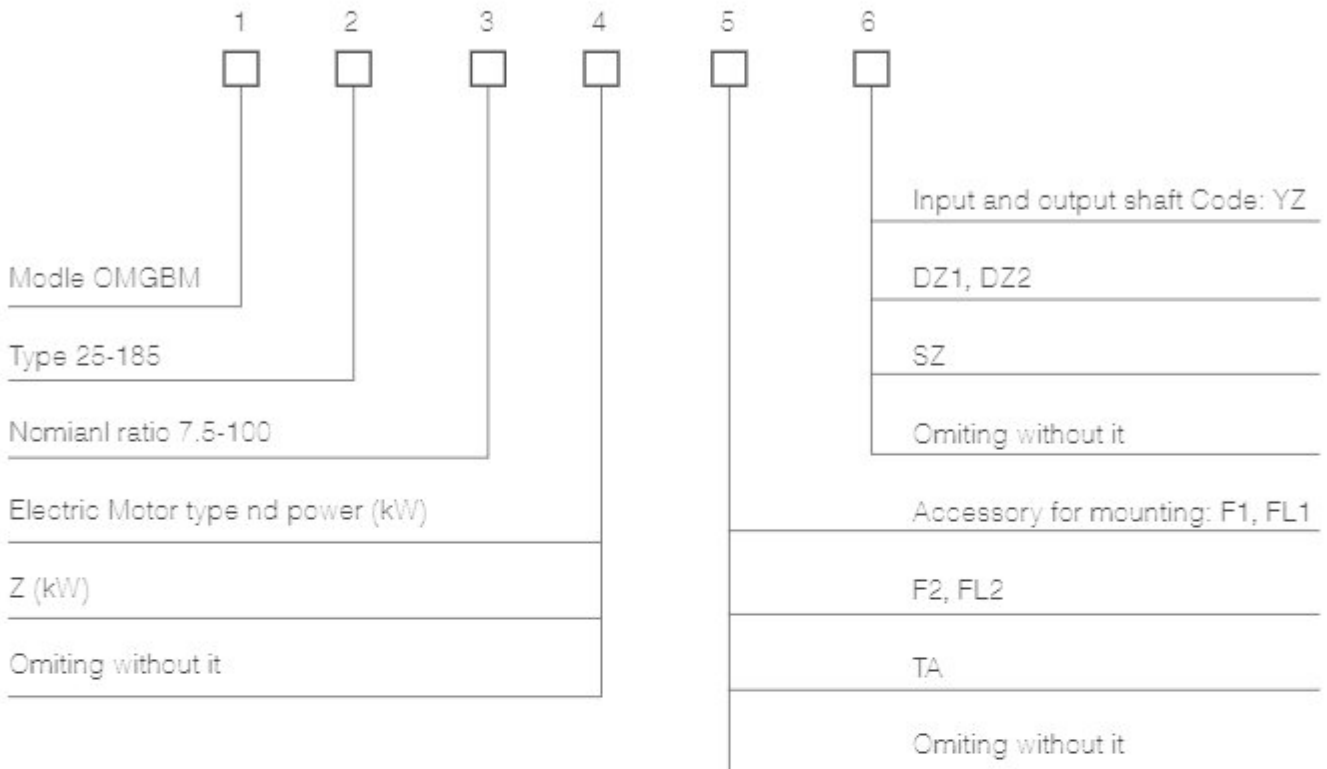

- 1 - Oil seal
- 2 - Bearing
- 3 - Breather vent
- 4 - O-type seal ring
- 5 - Input flange
- 6 - Oil seal
- 7 - Seal and cover
- 8 - Circlip hole use
- 9 - Bearing
- 10 - Oil baffle disc
- 11 - Worm
- 12 - Oil baffle disc
- 13 - Bearing
- 14 - Tank
- 15 - Plug screw
- 16 - Gear
- 17 - Bearing
- 18 - O-type seal ring
- 19 - Bearing and cover
- 20 - Oil seal



OMGBM

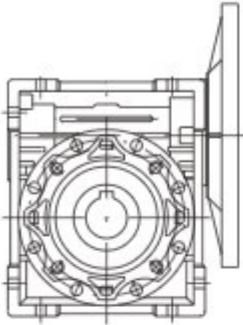

OMGBM YZ

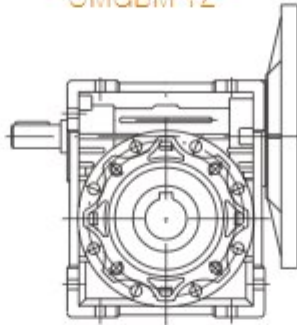

OMGBM TA

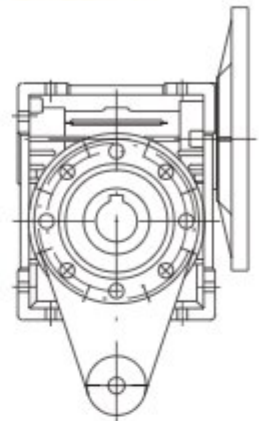

OMGB

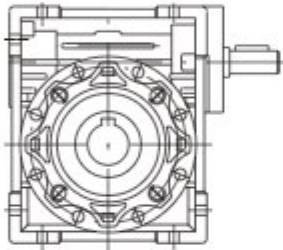

OMGB YZ

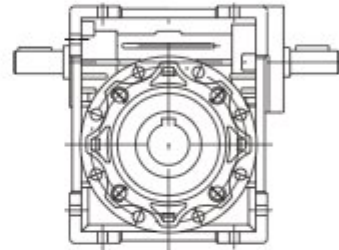

OMGB F1, FL1

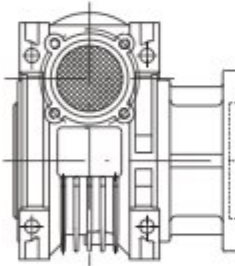

OMGB F2, FL2

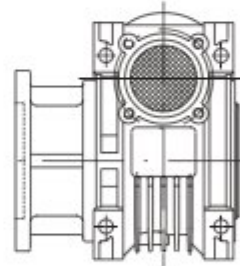

OMGB DZ1

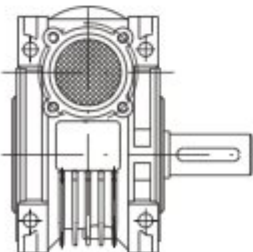

OMGB DZ2

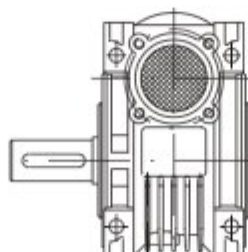

OMGB SZ

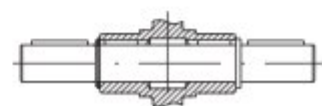
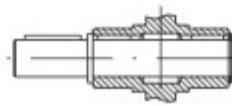
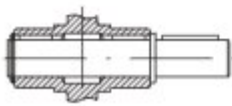
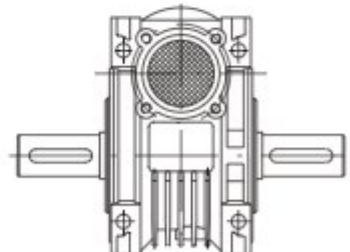

- Example of sign

**1.** OMGBM 40-30-Y0.18-F1-SZ

Means: model OMGBM

size: 40

Nominal ratio: 30

Equipped electric motor: 0.18KW in series Y

Output flange: F1

Double output shaft: SZ

**2.** OMGBM 40-30-F1

Means: model OMGBM

size: 40

Nominal ratio: 30

Without electric motor

Output flange: F1

- The carrying ability of worm microreducer

By table 2 and table 3, can find service factor of the worm microreducer

By table 4 and table 5, can find the carrying ability of worm microreducer

- Overall and mounting dimensions

By chart 2 and table 6, can find flange types and dimensions of hollow shaft.

By chart 3, chart 4 and table 7, can find overall dimensions

By chart 5 and table 8, can find dimensions of single/double output shaft.

By chart 6 and table 9, can find dimensions of extension shafts.

By chart 7 and table 10, can find dimensions of torque arms.

By chart 8, and speed reducer installation patterns, corresponding oil amount and types of lubricating oil.

By chart 9, and installation patterns of output flanges, output spindles.

By chart 10, can find the positions of junction box.

- The requirement of using and maintain

Do not make pressure on output part and box when mounting it. It must replace lubrication oil after it runs 400 hours when first using it, after it, replace lubrication oil per running 4000 hours.

It must keep coaxial degree and vertical degree in just lever when conjoining reducer with other device. Must keep plenty of oil lubrication in the reducer and check it often. Must add or replace in time when oil reduce or get bad. (lubrication type see attached table and chart 8) It is useful to keep reducer clean so that reducer radiates warmth more Efficiently.

(Attached table)

Reference circle of worm slide(m/s)	Lubrication type
<2.2	G-N680W(G-N460W)
>2.5 - 5	G-N320W
>5 - 12	G-N220W

By table 2 and 3, can find out the service factor(sf) about worm reducer. (Table 2)

NO of starts per hour <10			
Nature of load generated by driven machine	Hours running per day		
	<2	2-8	8-18
Uniform	sf=0.8	sf=1	sf=1.25
Moderate shock	sf=1	sf=1.25	sf=1.5
Heavy shock	sf=1.25	sf=1.5	sf=1.75

(Table 3)

NO of starts per hour <10			
Nature of load generated by driven machine	Hours running per day		
	<2	2-8	8-24
Uniform	sf=1	sf=1.25	sf=1.75
Moderate shock	sf=1.5	sf=1.75	sf=2
Heavy shock	sf=1.75	sf=2	sf=2.25

Date table (sf=1)

(Table 4)

I		n2											
			25	30	40	50	63	75	90	110	130	150	185
7.5	KW1 M2	187	0.25	0.41	0.90	1.58	2.84	4.06	6.3	10.4	16.1	25.8	39.1
			11	18	40	71	128	185	290	480	750	1200	1740
10	KW1 M2	140	0.21	0.32	0.69	1.23	2.19	3.25	5.11	8.57	13.5	20.2	30
			12	18	40	72	130	195	310	520	820	1240	1800
15	KW1 M2	93	0.15	0.23	0.48	0.88	1.65	2.30	4.09	6.48	10.3	13.9	21
			12	18	40	74	140	200	360	570	920	1250	1760
20	KW1 M2	70	0.12	0.18	0.37	0.68	1.22	1.88	3.10	4.83	7.76	11	19.6
			12	18	39	73	135	210	355	560	910	1300	2270
25	KW1 M2	56	-	0.18	0.30	0.54	0.98	1.47	2.43	4.12	6.49	8.4	13.8
			-	21	38	70	130	200	340	590	930	1200	1950
30	KW1 M2	47	0.09	0.15	0.31	0.57	1.06	1.48	2.57	3.90	6.35	7	14
			13	20	45	84	160	230	410	630	1040	1200	2200
40	KW1 M2	35	0.08	0.11	0.23	0.42	0.76	1.12	1.76	2.87	4.93	7.3	12.1
			13	18	41	76	145	220	360	610	1050	1550	2570
50	KW1 M2	28	0.06	0.09	0.18	0.34	0.60	0.89	1.38	2.35	3.83	5.4	9.3
			11	17	39	73	135	210	340	600	980	1400	2370
60	KW1 M2	23	0.04	0.08	0.15	0.28	0.51	0.75	1.13	1.9	3.05	4.2	7.6
			10	16	36	68	130	200	320	560	900	1260	2270
80	KW1 M2	18	-	0.05	0.12	0.22	0.39	0.58	0.83	1.34	2.26	3.1	5.6
			-	13	33	65	122	190	285	490	840	1150	2100
100	KW1 M2	14	-	-	0.09	0.16	0.34	0.48	0.67	1.07	1.70	2.29	4.1
			-	-	29	55	118	180	270	460	740	1000	1810



Data table (with 4 poles, 1400rpm motor)

(Table 5)

Type	iN	n2	KW <sub>1</sub>	M2	Sf	iAC	Type	iN	n2	KW <sub>1</sub>	M2	Sf	iAC	Type	iN	n2	KW <sub>1</sub>	M2	Sf	iAC
25	7.5	186.7	0.09	4	2.8	7.5	50	7.5	186.7	0.75	33	1.7	7.5	90	7.5	186.7	4	180	1.3	7.5
	10	140	0.09	5	2.3	10		10	140	0.75	42	1.3	10		10	140	4	236	1.1	10
	15	93.3	0.09	7	1.6	15		15	93.3	0.75	58	1.0	15		15	93.3	4	342	0.9	15
	20	70	0.09	9	1.3	20		20	70	0.75	81	0.9	20		20	70	4	458	0.8	20
	30	46.7	0.09	12	1.0	30		25	56	0.55	71	1.0	25		25	56	3	420	0.8	25
	40	35	0.09	15	0.9	40		30	46.7	0.55	81	1.0	30		30	46.7	3	479	0.9	30
	50	28	0.06	12	0.9	50		40	35	0.55	101	0.8	40		40	35	2.2	433	0.8	40
	60	23.3	0.06	14	0.7	60		50	28	0.37	80	0.9	50		50	28	2.2	492	0.6	50
						60	23.3	0.37	89	0.8	60	60	23.3	1.5	424	0.8	60			
						80	17.5	0.25	72	0.9	80	80	17.5	1.1	365	0.8	80			
						100	14	0.18	60	0.9	100	100	14	0.75	302	0.9	100			

Type	iN	n2	KW <sub>1</sub>	M2	Sf	iAC	Type	iN	n2	KW <sub>1</sub>	M2	Sf	iAC	Type	iN	n2	KW <sub>1</sub>	M2	Sf	iAC
30	7.5	186.7	0.18	7	1.9	7.5	63	7.5	186.7	1.5	68	1.5	7.5	110	7.5	186.7	7.5	345	1.4	7.5
	10	140	0.18	9	1.5	10		10	140	1.5	88	1.2	10		10	140	7.5	455	1.1	10
	15	93.3	0.18	13	1.0	15		15	93.3	1.5	126	0.9	15		15	93.3	5.5	484	1.2	15
	20	70	0.18	17	0.8	20		20	70	1.5	166	0.8	20		20	70	5.5	638	0.8	20
	25	56	0.18	21	1.0	25		25	56	1.1	146	0.9	25		25	56	5.5	790	0.8	25
	30	46.7	0.18	24	0.8	30		30	46.7	1.1	167	1.0	30		30	46.7	4	647	0.9	30
	40	35	0.12	19	0.9	40		40	35	1.1	207	0.7	40		40	35	3	638	0.9	40
	50	28	0.12	23	0.8	50		50	28	0.55	124	1.1	50		50	28	3	767	0.8	50
60	23.3	0.09	19	0.9	60	60	23.3	0.55	140	0.9	60	60	23.3	2.2	648	0.8	60			
80	17.5	0.06	14	0.9	80	80	17.5	0.37	115	1.1	80	80	17.5	1.5	548	0.8	80			
						100	14	0.37	129	0.9	100	100	14	1.1	473	0.9	100			

Type	iN	n2	KW <sub>1</sub>	M2	Sf	iAC	Type	iN	n2	KW <sub>1</sub>	M2	Sf	iAC	Type	iN	n2	KW <sub>1</sub>	M2	Sf	iAC
40	7.5	186.7	0.37	16	1.6	7.5	75	7.5	186.7	4	182	1.0	7.5	130	7.5	186.7	7.5	343	1.8	7.5
	10	140	0.37	27	1.3	10		10	140	3	180	1.1	10		10	140	7.5	453	1.5	10
	15	93.3	0.37	28	0.9	15		15	93.3	3	261	0.8	15		15	93.3	7.5	664	1.1	15
	20	70	0.37	39	1.0	20		20	70	2.2	240	0.8	20		20	70	7.5	864	0.8	20
	25	56	0.37	47	0.8	25		25	56	1.5	205	1.0	25		25	56	7.5	1074	0.8	25
	30	46.7	0.37	53	0.8	30		30	46.7	2.2	337	0.7	30		30	46.7	5.5	900	1.1	30
	40	35	0.25	44	0.9	40		40	35	1.1	216	1.0	40		40	35	5.5	1171	0.9	40
	50	28	0.22	47	0.8	50		50	28	1.1	264	0.8	50		50	28	5.5	1379	0.7	50
60	23.3	0.18	43	0.8	60	60	23.3	1.1	279	0.7	60	60	23.3	4	1179	0.8	60			
80	17.5	0.12	34	1.0	80	80	17.5	0.55	180	1.0	80	80	17.5	2.2	816	1.0	80			
100	14	0.12	38	0.8	100	100	14	0.55	206	0.9	100	100	14	2.2	966	0.8	100			

Type	iN	n2	KW <sub>1</sub>	M2	Sf	iAC	Type	iN	n2	KW <sub>1</sub>	M2	Sf	iAC
40	7.5	186.7	15	690	1.7	7.5	185	7.5	186.7	22	980	1.75	7.5
	10	140	15	870	1.4	10		10	140	22	1320	1.35	10
	15	93.3	11	945	1.25	15		15	93.3	18.5	1550	1.1	15
	20	70	11	1250	1.0	20		20	70	18.5	2140	1.0	20
	25	56	7.5	1040	1.1	25		25	56	11	1560	1.25	25
	30	46.7	7.5	1200	0.9	30		30	46.7	11	1760	1.3	30
	40	35	7.5	1550	1.0	40		40	35	11	2320	1.1	40
	50	28	5.5	1400	1.0	50		50	28	7.5	1920	1.2	50
60	23.3	4	1180	1.0	60	60	23.3	7.5	2210	1.0	60		
80	17.5	3	1130	1.0	80	80	17.5	5.5	2070	1.0	80		
100	14	2.2	975	1.0	100	100	14	4	1760	1.0	100		

Note  
n1---input speed rpm;  
n2---Output speed rpm;  
M2---Output torque Nm;  
sf---Service factor  
iN---Nominal ratio;  
iAC---Actual ratio.

The type of flange and Hollow inputshaft diameter D

(Table 6)

Type	Flange type	N	M	P	Nominal ratio										
					7.5	10	15	20	25	30	40	50	60	80	100
25	56B14	50	65	80	9	9	9	9	-	9	9	9	9	-	-
30	63B5	95	115	140	11	11	11	11	11	11	11	11	-	-	-
	63B14	60	75	90	11	11	11	11	11	11	11	11	-	-	-
40	56B14	50	65	80	9	9	9	9	9	9	9	9	9	9	-
	71B5	110	130	160	14	14	14	14	14	14	14	14	-	-	-
50	63B5	90	115	140	11	11	11	11	11	11	11	11	11	11	11
	80B5	130	165	200	19	19	19	19	19	19	19	19	-	-	-
	71B5	110	130	160	14	14	14	14	14	14	14	14	14	14	-
	63B5	95	115	140	11	11	11	11	11	11	11	11	11	11	11
	80B14	80	100	120	19	19	19	19	19	19	19	19	-	-	-
63	71B14	70	85	105	14	14	14	14	14	14	14	14	14	14	-
	90B5	130	165	200	24	24	24	24	24	24	24	-	-	-	-
	80B5	130	165	200	19	19	19	19	19	19	19	19	19	19	-
	71B5	110	130	160	14	14	14	14	14	14	14	14	14	14	14
75/90	71B14	70	85	105	14	14	14	14	14	14	14	14	14	14	14
	100/112B5	180	215	250	28	28	28	28	28	28	28	28	-	-	-
	90B5	130	165	200	24	24	24	24	24	24	24	24	24	24	-
	80B5	130	165	200	19	19	19	19	19	19	19	19	19	19	19
	90B14	95	115	140	24	24	24	24	24	24	24	24	24	24	-
110/130	80B14	80	100	120	19	19	19	19	19	19	19	19	19	19	19
	132B5	230	265	300	38	38	38	38	38	38	38	38	-	-	-
	100/112B5	180	215	250	28	28	28	28	28	28	28	28	28	28	28
	90B5	130	165	200	24	24	24	24	24	24	24	24	24	24	24
150	100/112B14	110	130	160	28	28	28	28	28	28	28	28	28	28	28
	90B14	95	115	140	24	24	24	24	24	24	24	24	24	24	24
	160B5	250	300	300	42	42	42	42	-	-	-	-	-	-	-
185	132B5	230	265	250	38	38	38	38	38	38	38	38	-	-	-
	100/112B5	180	215	200	28	28	28	28	28	28	28	28	28	28	28
	180B5	250	300	350	48	48	48	48	-	-	-	-	-	-	-
	160B5	250	300	350	42	42	42	42	42	42	42	42	-	-	-

Chart 2

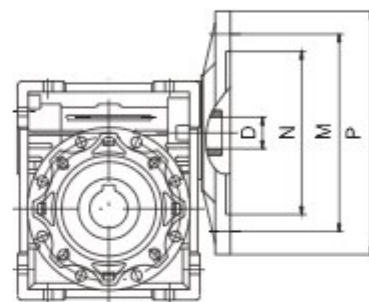
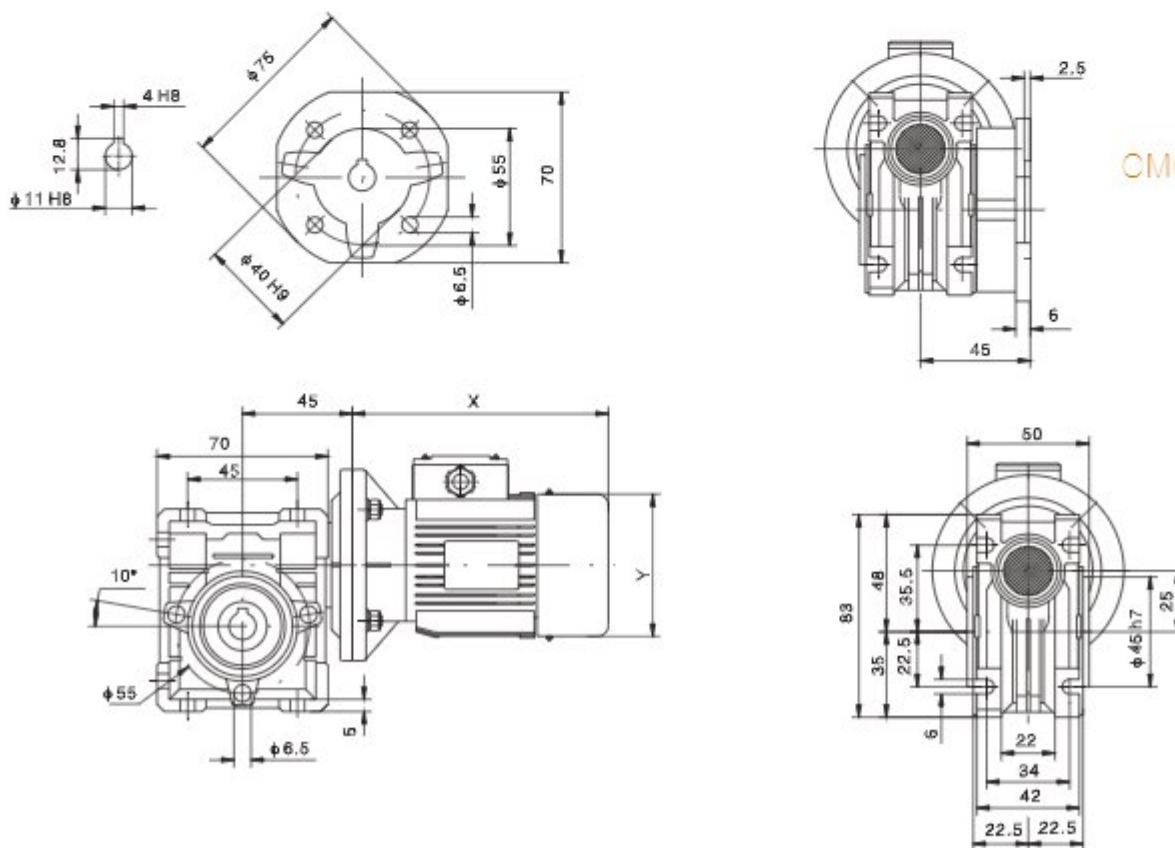

Chart 3



CMGBM

## OMGB

## OMGBM

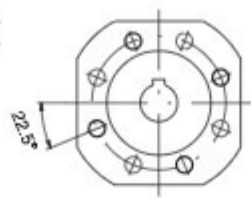
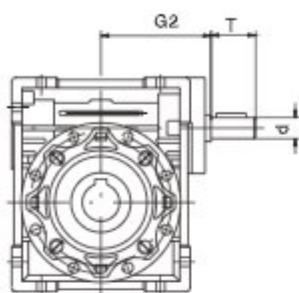

RV150,185

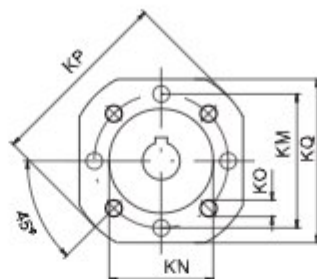

RV30-130

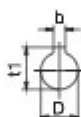
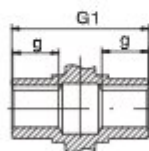
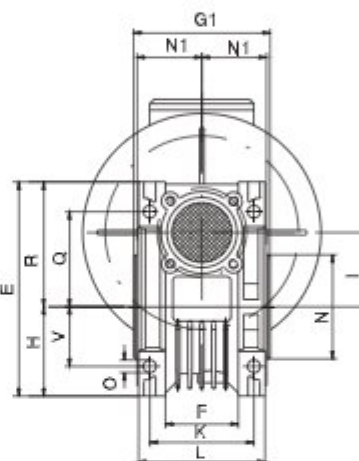
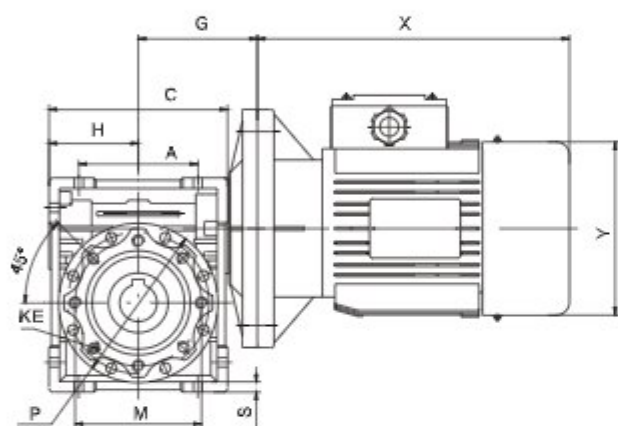
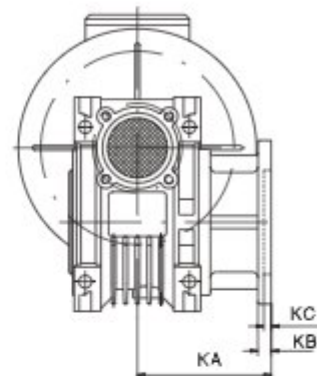

(Table 7)

Type	(Dimensions)																		
	A	C	D(H7)	E	F	G	H	I	L	M	N(h8)	O	P	Q	R	S	T	V	K
30	54	80	14	97	32	≤54	40	30	56	65	54	6,5	75	44	57	5,5	20	27	44
40	70	101	18	121,5	43	≤62	50	40	71	75	60	6,5	87	55	71,5	6,5	23	35	60
50	80	121,5	25	144	49	≤90	60	50	85	85	70	8,5	100	64	85	7	30	40	70
63	100	147,5	25	174	67	≤106	72	63	103	95	80	8,5	110	80	102	8	40	50	85
75	120	174	28	205	72	≤121	86	75	113	115	95	11	140	93	119	10	50	60	90
90	140	208	35	238	72	≤138	103	90	130	130	110	13	160	102	135	11	50	70	100
110	170	252,5	42	295		≤159	127,5	110	142	165	130	14	200	125	166,5	15	60	85	115
130	200	292,5	45	335		≤179	147,5	130	155	215	180	16	250	140	187,5	15	80	100	120
150	240	340	50	400		≤212	170	150	185	215	180	18	250	180	230	18	80	120	145
185	310	412	60	472		≤247	207	185	220	265	230	22	300	213	265	25	80	155	175

Type	(Dimensions)																			
	G1	G2	g	N1	KA		KB	KC	KE	α	KM	KN(h8)	KO	KP	KQ	d(j6)	b	t1	X	Y
					F	FL														
30	63	51	20	29	54,5		6	4	M6×11 (n4)	0°	68	50	6,5(4/90°)	80	70	9	5	16,3		
40	78	60	23	36,5	67	97	7	4	M6×8 (n4)	45°	87	60	9(4/90°)	110	95	11	6	20,8		
50	92	74	30	43,5	90	120	9	5	M8×10 (n4)	45°	90	70	11(4/90°)	125	110	14	8	28,3		
63	112	90	40	53	82	112	10	6	M8×14 (n8)	45°	150	115	11(4/90°)	180	142	19	8	28,3		
75	120	105	40	57	111		13	6	M8×14 (n8)	45°	165	130	14(4/90°)	200	170	24	8	31,3		
90	140	125	45	67	111		13	6	M10×18 (n8)	45°	175	152	14(4/90°)	210	200	24	10	38,3		
110	155	142	50	74	139		15	6	M10×18 (n8)	45°	220	170	14(4/90°)	270	250	28	12	45,3		
130	170	162	60	81	151,5		15	6	M12×20 (n8)	45°	255	180	16(4/45°)	320	290	30	14	48,8		
150	200	210	70	96	155		15	7	M12×21 (n8)	45°	255	180	16(8/45°)	320	290	35	14	53,8		
185	240	240	70	116	190		22	7	M16×25 (n8)	45°	350	280	22(8/45°)	400	390	40	18	64,4		

See overall dimensions fro electric motor



## Overall dimensions for electric motor

	56		63		71		80		90		100		112		132		160		180	
( kw )	0.06	0.09	0.12	0.18	0.25	0.37	0.55	0.75	1.1	1.5	2.2	3	4	5.5	7.5	11	15	18.5	22	
X	150		207		225		245		260	285	320		340	395	435	490	535	560	600	
Y	120		130		145		165		175		205		230	270		325		360		

Dimensions of single/double output shaft (Table 8)

Type	D(h6)	B	B1	L	L1	f	b	t
25	11	23	25.5	81	101	-	4	12.5
30	14	30	32.5	102	128	M6	5	16
40	18	40	43	128	164	M6	6	20.5
50	25	50	53.5	153	199	M10	8	28
63	25	50	53.5	173	219	M10	8	28
75	28	60	63.5	192	247	M10	8	31
90	35	80	84	234	308	M12	10	38
110	42	80	84.5	249	324	M16	12	45
130	45	80	85	265	340	M16	14	48.5
150	50	102	110	324	420	M20	14	53.5
185	60	112	120	374	480	M20	18	64

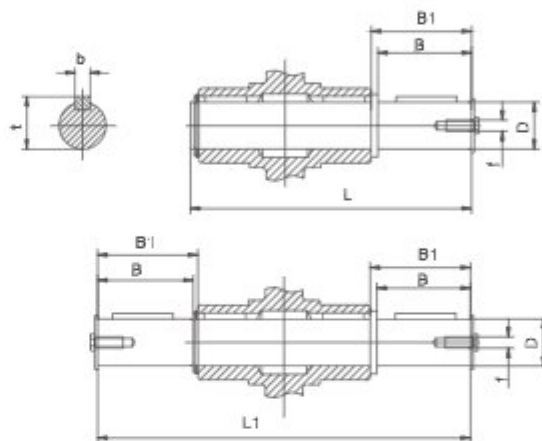

Chart 5

Dimensions of extension worm shafts (Speed is as same as electric motor)

Type	B	d(h6)	T	b	t
25	38	9	18	3	10.2
30	45	9	20	3	10.2
40	53	11	23	4	12.5
50	64	14	30	5	16
63	75	19	40	6	21.5
75	90	24	50	8	27
90	108	24	50	8	27
110	135	28	60	8	31
130	155	30	80	8	33
150	210	35	80	10	38
185	240	40	80	12	43

(Table 9)

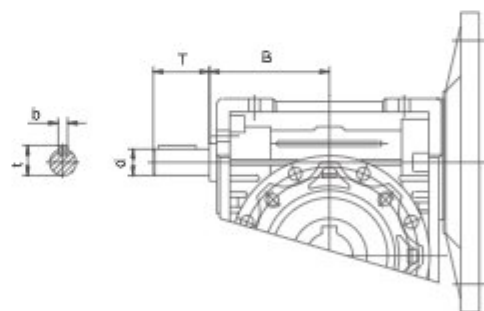

Chart 6

Dimensions of torque arms

Type	A	B	C	D	E	F	G	H	I
25	70	33	118	45	55	7	14	8	6
30	85	38	138	54	65	7	14	8	6
40	100	44	162	60	75	7	14	10	12
50	100	50	168	70	85	9	14	10	12
63	150	55	223	80	95	9	14	10	12
75	200	70	300	95	115	9	25	20	20
90	200	80	310	110	130	11	25	20	20
110	250	100	385	130	165	11	30	25	25
130	250	125	410	180	215	14	30	25	25
150	250	125	410	180	215	14	30	25	25
185	300	150	495	230	265	18	30	25	25

(Table 10)

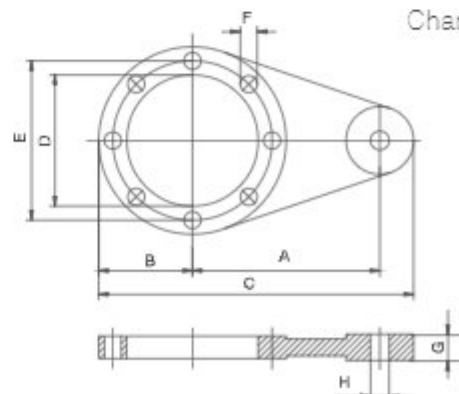
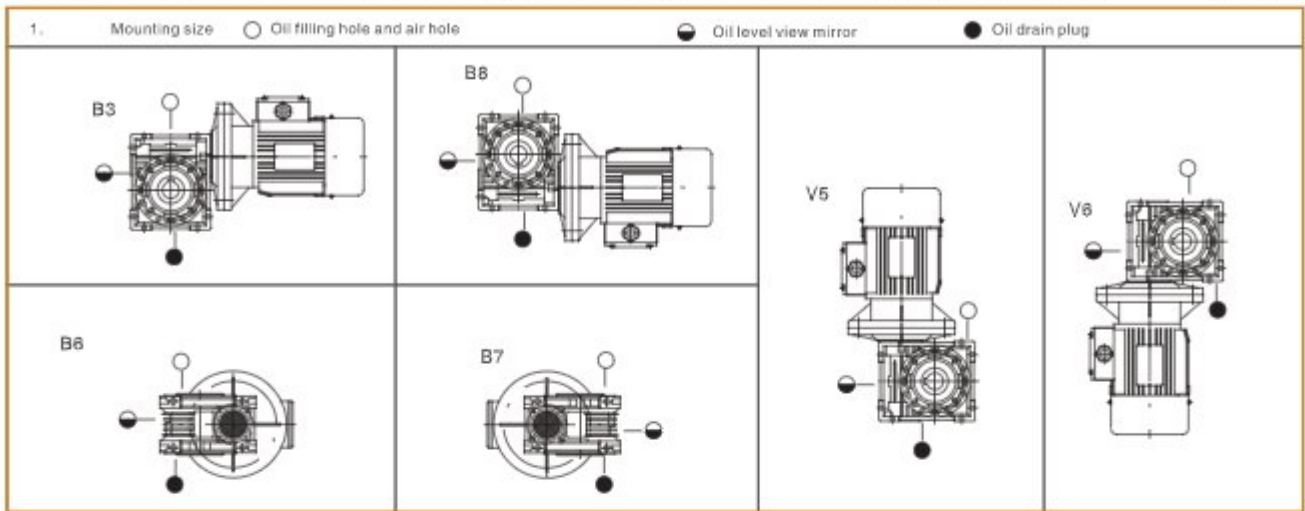

Chart 7

Installation type of reducer and the corresponding oil feeding amount and lubrication varieties

Chart 8



2. Oil amount to various installation patterns

Types of worm speed reducers		RV25	RV30	RV40	RV50	RV63	RV75	RV90	RV110	RV130	RV150	RV185
Lubricating oil	B3	0.02	0.04	0.08	0.15	0.3	0.55	1.0	3.0	4.5	5.5	8.0
	B6,B7								2.2	3.5	5.0	7.0
	B6								2.2	3.3	4.5	6.5
	V5								3.0	4.5	5.5	8.0
	V6								3.0	4.5	5.5	8.0

3. Lubricating oil

Types of worm speed reducers	RV25, RV40, RV50, RV63, RV75, RV90	RV25, RV40, RV50, RV63, RV75, RV90		
	Lubricant	Oil sintetice synthetic oil	Oil sintetice synthetic oil	Oil minerale mineral oil
Ambient Temperature	-25°C - +50°C	-25°C - +50°C	-5°C - +40°C	-15°C - +40°C
AGIP	TELIUM	MELLANAOIL 320	BLASIA 460	BLASIA 220
SHELL	TIVELA OIL SC320	OMALA OIL 320	OMALA OIL 460	OMALA OIL 220
ESSO	S220	S220	SPARTAN EP 460	SPARTAN EP 220
MOBIL	GLYGOYLE 30	MOBIL GEAR320	MOBIL GEAR 634	MOBIL GEAR 630
CASTROL	ALPHASYN PG 320	ALPHASYN PG 320	ALPHA MAX 460	ALPHA MAX 220
BP	ENERGOL SG-XP 320	ENERGOL SG-XP 320	ENETGOL SG-XP 460	ENETGOL SG-XP 220

Installation pattern of output flange F, FL,output spindle DZ, SZ of speed reducers

Chart 9

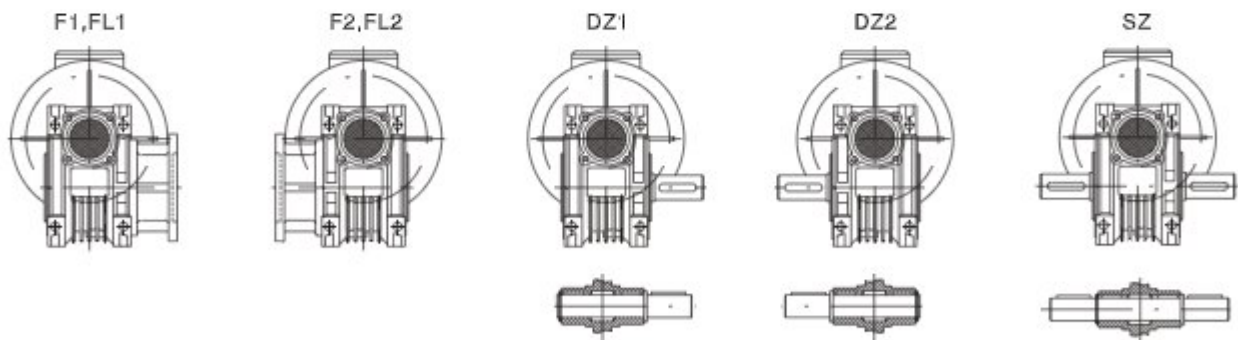

Installation pattern of motor wiring box

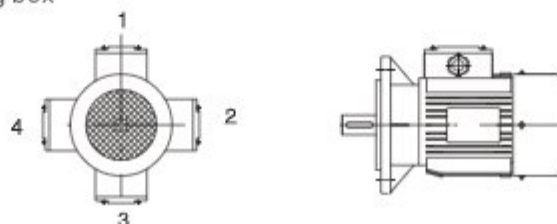

Chart 10

# CATALOGUE

OMGB - Gear Box Series



OME IN THE WORLD

H

HA

since 1967

**ORSATTI**  
GROUP

OME Electric Motors srl

Sede - Via N. Tartaglia N.6b 25064 Gussago (Bs) Italy - Cod.Fisc. e Partita IVA: 03276210980 - Tel.+39 030 3737072 - Fax. +39 030 2411395 - info@omemotors.com

[www.omemotors.com](http://www.omemotors.com)